

BATTERY CHARGERS

MULTIFUNCTION BATTERY CHARGER



GENERAL SAFETY.....5-38

EN GENERAL SAFETY RULES FOR THE USE **IT** SICUREZZA GENERALE PER L'USO **FR** INSTRUCTIONS GÉNÉRALES DE SÉCURITÉ POUR L'UTILISATION **ES** SEGURIDAD GENERAL PARA EL USO **DE** ALLGEMEINE SICHERHEITSVORSCHRIFTEN FÜR DEN GEBRAUCH **RU** ОБЩАЯ БЕЗОПАСНОСТЬ ПРИ ИСПОЛЬЗОВАНИИ **PT** SEGURANÇA GERAL PARA O USO **NL** ALGEMENE VEILIGHEID VOOR HET GEBRUIK **EL** ΓΕΝΙΚΗ ΑΣΦΑΛΕΙΑ ΓΙΑ ΤΗ ΧΡΗΣΗ **RO** SIGURANȚA GENERALĂ PENTRU FOLOSIRE **SV** ALLMÄNNA SÄKERHETSANVISNINGAR **CS** ZÁKLADNÍ BEZPEČNOSTNÍ POKYNY PRO POUŽITÍ **HR-SR** OPĆA SIGURNOST PRILIKOM UPOTREBE **PL** OGÓLNE BEZPIECZEŃSTWO PODCZAS UŻYTKOWANIA **FI** YLEISET TURVALLISUUSOHJEET KÄYTTÖÄ VARTEN **DA** ALMENE SIKKERHEDSREGLER FOR ANVENDELSE **NO** GENERELLE FORHOLDSREGLER FOR BRUK **SL** SPLOŠNA VARNOST PRI UPORABI **SK** ZÁKLADNÉ BEZPEČNOSTNÉ POKYNY PRE POUŽITIE **HU** ÁLTALÁNOS HASZNÁLATI BIZTONSÁGI ELŐÍRÁSOK **LT** BENDRIEJI SAUGOS REIKALAVIMAI EKSPLOATAVIMUI **ET** ÜLDISED HOIATUSED KASUTAMISEKS **LV** VISPĀRĒJIE DROŠĪBAS NOTEIKUMI LIETOŠANAS LAIKĀ **BG** ОБЩА БЕЗОПАСНОСТ ПРИ УПОТРЕБА **TR** GENEL KULLANIM GÜVENLİĞİ **AR** السلامة العامة للاستخدام

EN INSTRUCTION MANUAL.....	39	PL INSTRUKCJA OBSŁUGI.....	130
IT MANUALE D'ISTRUZIONE.....	46	FI OHJEKIRJA.....	137
FR MANUEL D'INSTRUCTIONS.....	53	DA INSTRUKTIONSMANUAL.....	144
ES MANUAL DE INSTRUCCIONES.....	60	NO BRUKERVEILEDNING.....	151
DE BEDIENUNGSANLEITUNG.....	67	SL PRIROČNIK Z NAVODILI ZA UPORABO....	158
RU РУКОВОДСТВО ПОЛЬЗОВАТЕЛЯ.....	74	SK NÁVOD NA POUŽITIE.....	165
PT MANUAL DE INSTRUÇÕES.....	81	HU HASZNÁLATI UTASÍTÁS.....	172
NL INSTRUCTIEHANDLEIDING.....	88	LT INSTRUKCIJŲ KNYGELĖ.....	179
EL ΕΓΧΕΙΡΙΔΙΟ ΠΡΗΣΗΣ.....	95	ET KASUTUSJUHEND.....	186
RO MANUAL DE INSTRUCȚIUNI.....	102	LV ROKASGRĀMATA.....	193
SV BRUKSANVISNING.....	109	BG РЪКОВОДСТВО С ИНСТРУКЦИИ.....	200
CS NÁVOD K POUŽITÍ.....	116	TR TALİMAT KILAVUZU.....	207
HR-SR PRIRUČNIK ZA UPOTREBU.....	123	AR دليل الارشادات.....	214



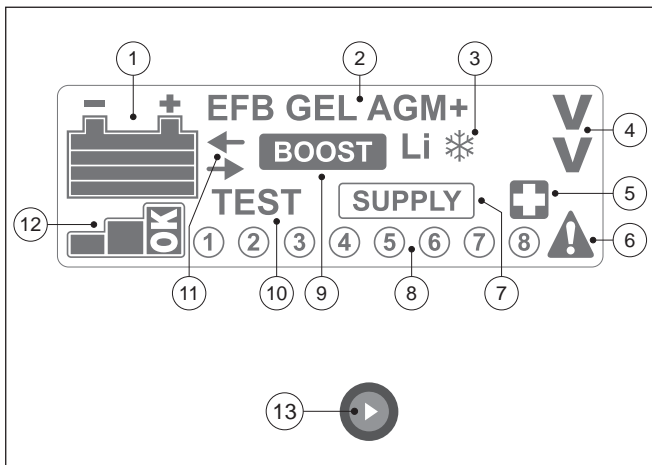

LCD version

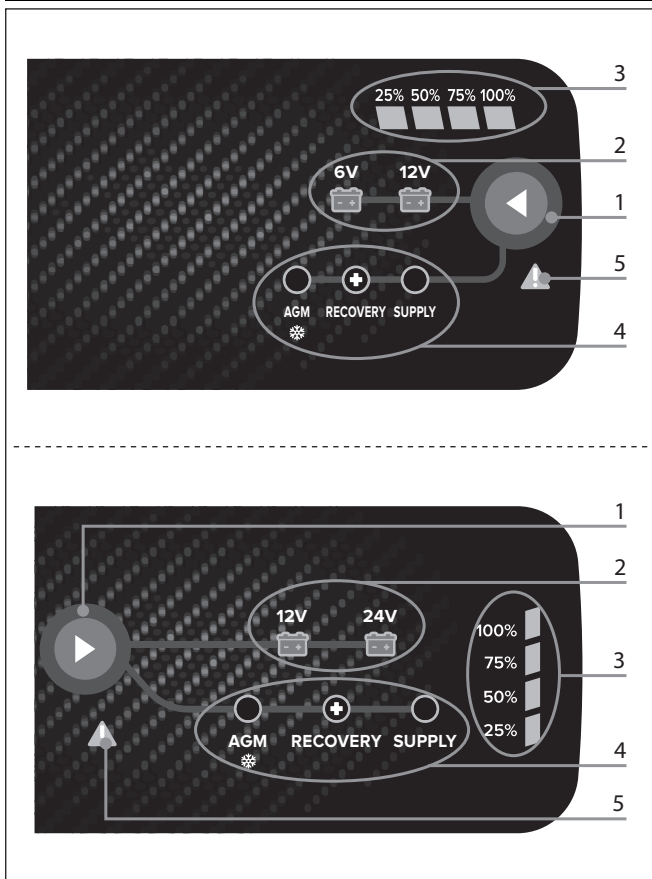

LED version



(EN)	EXPLANATION OF DANGER, MANDATORY AND PROHIBITION SIGNS.	(PL)	OBJAŚNIENIA ZNAKÓW OSTRZEGAWCZYCH, NAKAZU I ZAKAZU.
(IT)	LEGENDA SEGNALI DI PERICOLO, D'OBBLIGO E DIVIETO.	(FI)	VAROITUS, VELVOITUS, JA KIELTOMERKIT.
(FR)	LÉGENDE SIGNAUX DE DANGER, D'OBLIGATION ET D'INTERDICTION.	(DA)	OVERSIGT OVER FARE, PLIGT OG FORBUDSSIGNALER.
(ES)	LEYENDA SEÑALES DE PELIGRO, DE OBLIGACIÓN Y PROHIBICIÓN.	(NO)	SIGNALERINGSTEKST FOR FARE, FORPLIKTELSE OG FORBUDT.
(DE)	LEGENDE DER GEFAHREN-, GEBOTS- UND VERBOTSZEICHEN.	(SL)	LEGENDA SIGNALOV ZA NEVARNOST, ZA PREDPISANO IN PREPOVEDANO.
(RU)	ЛЕГЕНДА СИМВОЛОВ БЕЗОПАСНОСТИ, ОБЯЗАННОСТИ И ЗАПРЕТА.	(SK)	VYSVETLIVKY K SIGNÁLOM ZABEZPEČENSTVA, PRÍKAZOM A ZÁKAZOM.
(PT)	LEGENDA DOS SINAIS DE PERIGO, OBRIGAÇÃO E PROIBIDO.	(HU)	A VESZÉLY, KÖTELEZETTSÉG ÉS TILTÁS JELZÉSEINEK FELIRATAI.
(NL)	LEGENDE SIGNALLEN VAN GEVAAR, VERPLICHTING EN VERBOD.	(LT)	PAVOJAUS, PRIVALOMUMŲ IR DRAUDŽIAMŲJŲ ŽENKLŲ PAAIŠKINIMAS.
(EL)	ΛΕΞΑΝΤΑ ΣΗΜΑΤΩΝ ΚΙΝΔΥΝΟΥ, ΥΠΟΧΡΕΩΣΗΣ ΚΑΙ ΑΠΑΓΟΡΕΥΣΗΣ.	(ET)	OHUD, KOHUSTUSED JA KEELUD.
(RO)	LEGENDĂ INDICATOARE DE AVERTIZARE A PERICOLELOR, DE OBLIGARE ȘI DE INTERZICERE.	(LV)	BĪSTAMĪBU, PIENĀKUMU UN AIZLIEGUMA ZĪMJU PASKAIDROJUMI.
(SV)	BILDTXT SYMBOLER FÖR FARA, RÅBUD OCH FÖRBUD.	(BG)	ЛЕГЕНДА НА ЗНАЦИТЕ ЗА ОПАСНОСТ, ЗАДЪЛЖИТЕЛНИ И ЗА ЗАБРАНА.
(CS)	VYSVĚTLIVKY K SIGNÁLŮM NEBEZPEČÍ, PŘÍKAZŮM A ZÁKAZŮM.	(TR)	TEHLİKE, MECBURİYET VE YASAK İŞARETLERİNİN AÇIKLAMALARI.
(HR-SR)	LEGENDA OZNAKA OPASNOSTI, OBAVEZA I ZABRANA.	(AR)	مفاتيح رموز الخطر والإلزام والحظر.

	<p>(EN) DANGER OF EXPLOSION - (IT) PERICOLO ESPLOSIONE - (FR) RISQUE D'EXPLOSION - (ES) PELIGRO EXPLOSIÓN - (DE) EXPLOSIONSGEFAHR - (RU) ОПАСНОСТЬ ВЗРЫВА - (PT) PERIGO DE EXPLOSAO - (NL) GEVAAR ONTPLOFFING - (EL) ΚΙΝΔΥΝΟΣ ΕΚΡΗΞΗΣ - (RO) PERICOL DE EXPLOZIE - (SV) FARA FÖR EXPLOSION - (CS) NEBEZPEČÍ VÝBUCHU - (HR-SR) OPASNOST OD EKSPLOZIJE - (PL) NIEBEZPIECZEŃSTWO WYBUCHU - (FI) RÄJÄHDYSVAARA - (DA) SPRÆNGFARE - (NO) FARE FOR EKSPLOSJON - (SL) NEVARNOST EKSPLOZIJE - (SK) NEBEZPEČENSTVO VÝBUCHU - (HU) ROBBANÁS VESZÉLYE - (LT) SPROGIMO PAVOJUS - (ET) PLAHVATUSOHT - (LV) SPRĀDZIENBĪSTAMĪBA - (BG) ОПАСНОСТ ОТ ЕКСПЛОЗИЯ - (TR) PATLAMA TEHLİKESİ - (AR) خطر الانفجار</p>
	<p>(EN) GENERAL HAZARD - (IT) PERICOLO GENERICO - (FR) DANGER GÉNÉRIQUE - (ES) PELIGRO GENÉRICO - (DE) GEFAHR ALLGEMEINER ART - (RU) ОБЩАЯ ОПАСНОСТЬ - (PT) PERIGO GERAL - (NL) ALGEMEEN GEVAAR - (EL) ΓΕΝΙΚΟΣ ΚΙΝΔΥΝΟΣ - (RO) PERICOL GENERAL - (SV) ALLMÄN FARA - (CS) VŠEOBECNÉ NEBEZPEČÍ - (HR-SR) OPĆA OPASNOST - (PL) OGÓLNE NIEBEZPIECZEŃSTWO - (FI) YLEINEN VAARA - (DA) ALMEN FARE - (NO) GENERISK FARE STRÅLNING - (SL) SPLOŠNA NEVARNOST - (SK) VŠEOBECNÉ NEBEZPEČENSTVO - (HU) ÁLTALÁNOS VESZÉLY - (LT) BENDRAS PAVOJUS - (ET) ÜLDINE OHT - (LV) VISPĀRĪGA BĪSTAMĪBA - (BG) ОБЩИ ОПАСНОСТИ - (TR) GENEL TEHLİKE - (AR) خطر عام</p>
	<p>(EN) DANGER OF CORROSIVE SUBSTANCES - (IT) PERICOLO SOSTANZE CORROSIVE - (FR) SUBSTANCES CORROSIVES DANGEREUSES - (ES) PELIGRO SUSTANCIAS CORROSIVAS - (DE) ÄTZENDE GEFAHRENSTOFFE - (RU) ОПАСНОСТЬ КОРРОЗИВНЫХ ВЕЩЕСТВ - (PT) PERIGO SUBSTÂNCIAS CORROSIVAS - (NL) GEVAAR CORROSIEVE STOFFEN - (EL) ΚΙΝΔΥΝΟΣ ΔΙΑΒΡΩΤΙΚΩΝ ΟΥΣΙΩΝ - (RO) PERICOL DE SUBSTANȚE COROSIVE - (SV) FARA FRÅTÄNDE ÄMNER - (CS) NEBEZPEČÍ PLYNOUCÍ Z KOROSIVNÍCH LÁTEK - (HR-SR) OPASNOST OD KOROZIVNIH TVARI - (PL) NIEBEZPIECZEŃSTWO WYDZIAŁANIA SUBSTANCJI KOROZYJNYCH - (FI) SYÖVYTTÄVIEN AINEIDEN VAARA - (DA) FARE, ÆTSENDE STOFFER - (NO) FARE: KORROSIVE SUBSTANSE - (SL) NEVARNOST JEDKE SNOVI - (SK) NEBEZPEČENSTVO VYPĽYVAJÚCE Z KORÓZIVNYCH LÁTOK - (HU) MARÓ HATÁSÚ ANYAGOK VESZÉLYE - (LT) KOROZINIŲ MEDŽIAGŲ PAVOJUS - (ET) KORRUDEERUVATE MATERIAALIDE OHT - (LV) KORŪZIJAS VIĒLU BĪSTAMĪBA - (BG) ОПАСНОСТ ОТ КОРОЗИВНИ ВЕЩЕСТВА - (TR) KORŪZİF MADDE TEHLİKESİ - (AR) خطر المواد المسببة للتآكل</p>
	<p>(EN) DANGER OF ELECTRIC SHOCK - (IT) PERICOLO SHOCK ELETTRICO - (FR) RISQUE DE CHOC ÉLECTRIQUE - (ES) PELIGRO DESCARGA ELÉCTRICA - (DE) STROMSCHLAGGEFAHR - (RU) ОПАСНОСТЬ ПОРАЖЕНИЯ ЭЛЕКТРИЧЕСКИМ ТОКОМ - (PT) PERIGO DE CHOQUE ELÉTRICO - (NL) GEVAAR ELEKTROSHOCK - (EL) ΚΙΝΔΥΝΟΣ ΗΛΕΚΤΡΟΠΛΗΞΙΑΣ - (RO) PERICOL DE ELECTROCUTARE - (SV) FARA FÖR ELEKTRISK STÖT - (CS) NEBEZPEČÍ ZÁSAHU ELEKTRICKÝM PROUDEM - (HR-SR) OPASNOST STRUJNOG UDARA - (PL) NIEBEZPIECZEŃSTWO SZOKU ELEKTRYCZNEGO - (FI) SÄHKÖISKUN VAARA - (DA) FARE FOR ELEKTRISK STØD - (NO) FARE FOR ELEKTRISK STØT - (SL) NEVARNOST ELEKTRIČNEGA UDARA - (SK) NEBEZPEČENSTVO ZÁSAHU ELEKTRICKÝM PRŮDOM - (HU) ÁRAMÜTÉS VESZÉLYE - (LT) ELEKTROS SMŪGIO PAVOJUS - (ET) ELEKTRILÖÖGIOHT - (LV) ELEKTROŠOKA BĪSTAMĪBA - (BG) ОПАСНОСТ ОТ ТОКОВ УДАР - (TR) ELEKTRİK ŞOK TEHLİKESİ - (AR) خطر الصدمة الكهربائية</p>



(EN) Symbol indicating separation of electrical and electronic appliances for refuse collection. The user is not allowed to dispose of these appliances as solid, mixed urban refuse, and must do it through authorised refuse collection centres.

- (IT) Simbolo che indica la raccolta separata delle apparecchiature elettriche ed elettroniche. L'utente ha l'obbligo di non smaltire questa apparecchiatura come rifiuto municipale solido misto, ma di rivolgersi ai centri di raccolta autorizzati.

- (FR) Symbole indiquant la collecte différenciée des appareils électriques et électroniques. L'utilisateur ne peut éliminer ces appareils avec les déchets ménagers solides mixtes, mais doit s'adresser à un centre de collecte autorisé.

- (ES) Símbolo que indica la recogida por separado de los aparatos eléctricos y electrónicos. El usuario tiene la obligación de no eliminar este aparato como desecho urbano sólido mixto, sino de dirigirse a los centros de recogida autorizados.

- (DE) Symbol für die getrennte Erfassung elektrischer und elektronischer Geräte. Der Benutzer hat pflichtgemäß dafür zu sorgen, daß dieses Gerät nicht mit dem gemischt erfaßten festen Siedlungsabfall entsorgt wird. Stattdessen muß er eine der autorisierten Entsorgungsstellen einschalten.

- (RU) Символ, указывающий на раздельный сбор электрического и электронного оборудования. Пользователь не имеет права выбрасывать данное оборудование в качестве смешанного твердого бытового отхода, а обязан обращаться в специализированные центры сбора отходов.

- (PT) Símbolo que indica a reunião separada das aparelhagens eléctricas e electrónicas. O utente tem a obrigação de não eliminar esta aparelhagem como lixo municipal sólido misto, mas deve procurar os centros de recolha autorizados.

- (NL) Symbool dat wijst op de gescheiden inzameling van elektrische en elektronische toestellen. De gebruiker is verplicht deze toestellen niet te lozen als gemengde vaste stadsafval, maar moet zich wenden tot de geautoriseerde ophaalcentra.

- (EL) Σύμβολο που δείχνει τη διαφοροποιημένη συλλογή των ηλεκτρικών και ηλεκτρονικών συσκευών. Ο χρήστης υποχρεούται να μην διοχετεύει αυτή τη συσκευή σαν μικτό στερεό αστικό απόβλητο, αλλά να απευθύνεται σε εγκεκριμένα κέντρα συλλογής.

- (RO) Simbol ce indică depozitarea separată a aparatelor electrice și electronice. Utilizatorul este obligat să nu depoziteze acest aparat împreună cu deșeurile solide mixte ci să-l predea într-un centru de depozitare a deșeurilor autorizat.

- (SV) Symbol som indikerar separat sopsortering av elektriska och elektroniska apparater. Användaren får inte sortera denna anordning tillsammans med blandat fast hushållsavfall, utan måste vända sig till en auktoriserad insamlingsstation.

- (CS) Symbol označující separovaný sběr elektrických a elektronických zařízení. Uživatel je povinen nezlikvidovat toto zařízení jako pevný smíšený komunální odpad, ale obrátit se s ním na autorizovaný sběrný.

- (HR-SR) Simbol koji označava posebno sakupljanje električnih i elektronskih aparata. Korisnik ne smije odložiti ovaj aparat kao običan kruti otpad, već se mora obratiti ovlaštenim centrima za sakupljanje.

- (PL) Symbol, który oznacza sortowanie odpadów aparatury elektrycznej i elektronicznej. Zabrania się likwidowania aparatury jako mieszanego odpadów miejskich stałych, obowiązkiem użytkownika jest skierowanie się do autoryzowanych ośrodków gromadzących odpady.

- (FI) Symboli, joka ilmoittaa sähkö- ja elektroniikkalaitteiden erillisen keräyksen. Käyttäjän velvollisuus on kääntyä valtuutettujen keräyspisteiden puoleen eikä välittää laitetta kunnallisena sekajätteenä.

- (DA) Symbol, der står for særlig indsamling af elektriske og elektroniske apparater. Brugeren har pligt til ikke at bortkassere dette apparat som blandet, fast byaffald; der skal rettes henvendelse til et autoriseret indsamlingscenter.

- (NO) Symbol som angir separat sortering av elektriske og elektroniske apparater. Brukeren må oppfylle forpliktelsen å ikke kaste bort dette apparatet sammen med vanlige hjemmeavfallet, uten henvende seg til autorisert oppsamlingsentraler.

- (SL) Simbol, ki označuje ločeno zbiranje električnih in elektronskih aparatov. Uporabnik tega aparata ne sme zavreči kot navaden gospodinjski trden odpad, ampak se mora obrniti na pooblaščen centre za zbiranje.

- (SK) Symbol označujúci separovaný zber elektrických a elektronických zariadení. Užívateľ nesmie likvidovať toto zariadenie ako pevný zmiešaný komunálny odpad, ale je povinný doručiť ho do autorizovaný zberní.

- (HU) Jelölés, mely az elektromos és elektronikus felszerelések szelektív hulladékgyűjtését jelzi. A felhasználó köteles ezt a felszerelést nem a városi törmelék hulladékkal együttesen gyűjteni, hanem erre engedéllyel rendelkező hulladékgyűjtő központhoz fordulni.

- (LT) Simbolis, nurodantis atskirų nebenaudojamų elektrinių ir elektroninių prietaisų surinkimą. Vartotojas negali išmesti šių prietaisų kaip mišrių kietųjų komunalinių atliekų, bet privalo kreiptis į specializuotus atliekų surinkimo centrus.

- (ET) Sümbol, mis tähistab elektri- ja elektroonikaseadmete eraldi kogumist. Kasutaja kohustuseks on pöörduda volitatud kogumiskeskuste poole ja mitte käsitleda seda aparati kui munitsipaalne segajääd.

- (LV) Simbols, kas norāda uz to, ka utilizācija ir jāveic atsevišķi no citām elektriskajām un elektroniskajām ierīcēm. Lietotāja pienākums ir neizmest šo aparāturu municipālajā cieto atkritumu izgāztuvē, bet nogādāt to pilnvarotajā atkritumu savākšanas centrā.

- (BG) Символ, който означава разделно събиране на електрическата и електронна апаратура. Ползвателят се задължава да не изхвърля тази апаратура като смесен твърд отпадък в контейнерите за смет, поставени от общината, а трябва да се обърне към специализираните за това центрове.

- (TR) Elektrikli ve elektronik cihazların ayrı toplanacağı belirtilen sembol. Kullanıcı bu cihazı karışık evsel kati atık olarak bertaraf etmemek ve yetkili toplama merkezlerine başvurmakla yükümlüdür.

- (AR) رمز يُشير إلى التجميع المنفصل للأجهزة الكهربائية والإلكترونية. يجب على المستخدم عدم التخلص من هذا الجهاز وكأنه نفايات البلدية الصلبة المختلطة، بل عليه التوجه إلى مراكز تجميع النفايات المُصرح بها



FR

Cet appareil se recycle

À DÉPOSER EN MAGASIN



OU

À DÉPOSER EN DÉCHÈTERIE



Points de collecte sur www.quefairedemesdechets.fr



WARNING: BEFORE USING THE BATTERY CHARGER READ THE INSTRUCTION MANUAL CAREFULLY.

1. GENERAL SAFETY RULES WHEN USING THIS BATTERY CHARGER



- During the charge the battery produces explosive gases, avoid the formation of flames and sparkes. **DO NOT SMOKE.**
- Position the batteries to be charged in a well-ventilated place.



- **Inexperience and untrained people should be properly instructed before using the appliance.**
- **This appliance can be used by children aged from 8 years and above and persons with reduced physical, sensory or mental capabilities or lack of experience and knowledge if they have been given supervision or instruction concerning use of the appliance in a safe way and understand the hazards involved.**
- **Children shall not play with the appliance.**
- **Cleaning and user maintenance shall not be made by children without supervision.**
- Disconnect the mains cable before connecting to or disconnecting the charging cables from the battery.
- Do not connect or disconnect the clamps to or from the battery with the battery charger operating.
- Never use the battery charger inside the car or in the bonnet.
- Substitute the mains cable only with an original one.
- If the supply cord is damaged, it must be replaced by the manufacturer, its service agent or similarly qualified persons in order to avoid a hazard.
- Do not use the battery charger to charge batteries which are not rechargeable.
- Make sure the available power supply voltage corresponds to that shown on the battery charger rating plate.
- To avoid damaging the vehicle's electronics, read, keep and take very careful note of the information supplied by the vehicle manufacturer, when using the battery charger either for charging or starting; the same applies to the instructions supplied by the battery manufacturer.
- This battery charger has components such as switches and relays which can cause arcs or sparks. Therefore when using it in a garage or in a similar place set the battery charger in a suitable case.
- Repair or maintenance of the inside of the battery charger can be executed only by skilled technicians.



ALWAYS DISCONNECT THE POWER SUPPLY CABLE FROM THE MAINS BEFORE ANY MAINTENANCE INTERVENTION ON THE BATTERY CHARGER.

2. INTRODUCTION AND GENERAL DESCRIPTION

- This battery charger is used to charge electrolyte free lead batteries, sealed batteries and lithium batteries used on motor vehicles (petrol and diesel), motorcycles, boats etc.
- Rechargeable accumulators according to the output voltage available: 6V, 12V and 24V (according to the plate data).
- This battery charger, according to the model, can have a power supply of 230V 50/60Hz or 110V 50/60Hz (according to the plate data) mono-phase.

The charge voltage and current supplied by the device are electrically controlled and have an IU or U charge curve.

- Standard features:
 - The device allows you to connect different types of output cables for the charging of batteries:
 - cables fitted with eyelets;
 - cables fitted with clamps.

3. INSTALLATION BATTERY CHARGER POSITION

- Place the battery charger in a stable position during use.
- Do not lift the battery charger using the power cable or charge cable.

CONNECTION TO THE MAINS

- The battery charger must only be connected to a mains power supply with neutral conductor connected to earth. Make sure that the mains voltage is equivalent to the operating voltage.
- The power line must have a protection system, such as fuses or circuit breakers, that can support the maximum apparatus absorption (according to the plate data).
- Use the relative power cable when connecting to the mains.
- Any power cable extensions must be of suitable size, never lower than that of the supplied power cable.

4. OPERATION BATTERY CHARGING PREPARATIONS

N.B.: Before charging, make sure the capacity (Ah) of the batteries to be charged is not lower than that indicated on the rating plate (C min).

Follow the instructions scrupulously in the order given below.

- Remove the battery covers (if present), so that the gas produced during charging can exit.
- Make sure the level of electrolyte covers the battery plates; if they are not covered, add distilled water until they are submerged by 5-10 mm.



WARNING! BE VERY CAREFUL WHILE CARRYING OUT THIS OPERATION BECAUSE THE ELECTROLYTE IS AN EXTREMELY CORROSIVE ACID.

- Make sure the battery charger is disconnected from the mains.
- Check the polarity of the battery terminals: the (+) symbol is positive, the (-) symbol is negative.

N.B.: If the symbols are not clear, remember that the positive terminal is not connected to the vehicle chassis.

- Connect the red charging clamp to the positive battery terminal (+ symbol).
- Connect the black clamp to the machine

chassis, at a distance from the vehicle battery and the fuel pipe.

N.B.: if the battery is not installed inside the vehicle, directly connect to the negative battery terminal (- symbol).

5. USEFUL ADVICE

- Clean the positive and negative terminals of possible oxidation so as to ensure good contact with the clamps.
- If the battery charger is used with a battery which is always connected to a vehicle, check the instruction and/or maintenance manual of the vehicle under the paragraph: "ELECTRIC SYSTEM" or "MAINTENANCE". Before charging it is advisable to disconnect the positive cable which is part of the electrical system of the vehicle.

(IT)



ATTENZIONE: PRIMA DI UTILIZZARE IL CARICABATTERIE LEGGERE ATTENTAMENTE IL MANUALE D'ISTRUZIONE!

1. SICUREZZA GENERALE PER L'USO DI QUESTO CARICABATTERIE



- Durante la carica le batterie emanano gas esplosivi, evitate che si formino fiamme e scintille. **NON FUMARE.**
- Posizionare le batterie in carica in un luogo areato.



- **Le persone inesperte devono essere opportunamente istruite prima di utilizzare l'apparecchio.**
- **L'apparecchio può essere utilizzato da bambini di età non inferiore a 8 anni e da persone con ridotte capacità fisiche, sensoriali o mentali, o prive di esperienza o della necessaria conoscenza, purché sotto sorveglianza oppure dopo che le stesse abbiano ricevuto istruzioni relative all'uso sicuro dell'apparecchio e alla comprensione dei pericoli ad esso inerenti.**
- **I bambini non devono giocare con l'apparecchio.**
- **La pulizia e la manutenzione destinata ad essere effettuata dall'utilizzatore non deve essere effettuata da bambini senza sorveglianza.**
- Disinserire il cavo di alimentazione dalla rete prima di connettere o sconnettere i cavi di carica dalla batteria.
- Non collegare né scollegare le pinze alla batteria con il caricabatterie funzionante.
- Non usare nel modo più assoluto il caricabatterie all'interno di un'autovettura o del cofano.
- Sostituire il cavo di alimentazione solo con un cavo originale.
- Se il cavo di alimentazione è danneggiato, esso deve essere sostituito dal costruttore o dal suo servizio assistenza tecnica o comunque da una persona con qualifica simile, in modo da prevenire ogni rischio.

- Non utilizzare il caricabatterie per ricaricare batterie di tipo non ricaricabili.
- Verificare che la tensione di alimentazione disponibile sia corrispondente a quella indicata sulla targa dati del caricabatterie.
- Per non danneggiare l'elettronica dei veicoli, leggere, conservare, rispettare scrupolosamente le avvertenze fornite dai costruttori dei veicoli stessi, quando si utilizza il caricabatterie sia in carica che in avviamento; lo stesso vale per le indicazioni fornite dal costruttore di batterie.
- Questo caricabatterie comprende parti, quali interruttori o relè, che possono provocare archi o scintille; pertanto se usato in una autorimessa o in un ambiente simile, porre il caricabatterie in un locale o in una custodia adatta allo scopo.
- Interventi di riparazione o manutenzione all'interno del caricabatterie devono essere eseguiti solo da personale esperto.



DISINSERIRE SEMPRE IL CAVO DI ALIMENTAZIONE DALLA RETE PRIMA DI EFFETTUARE QUALSIASI INTERVENTO DI MANUTENZIONE SUL CARICABATTERIE.

2. INTRODUZIONE E DESCRIZIONE GENERALE

- Questo caricabatterie permette la carica di batterie al piombo ad elettrolita libero, ermetiche e al litio usate su veicoli a motore (benzina e diesel), motocicli, imbarcazioni, etc..
- Accumulatori ricaricabili in funzione della tensione di uscita disponibile: 6V, 12V e 24V (secondo targa dati).
- Questo caricabatteria, a seconda del modello, può essere con alimentazione 230V 50/60Hz o 110V 50/60Hz (secondo targa dati) monofase. La corrente e la tensione di carica fornite dall'apparecchio sono controllate elettronicamente e seguono la curva di carica IU o U.
- Dotazioni di serie:
 - L'apparecchio permette di collegare in uscita diverse tipologie di cavi per la ricarica delle batterie:
 - cavi muniti di occhielli;
 - cavi muniti di pinze.

3. INSTALLAZIONE

UBICAZIONE DEL CARICABATTERIE

- Durante il funzionamento posizionare il caricabatteria in modo stabile.
- Evitare di sollevare il caricabatteria tramite il cavo di alimentazione o tramite il cavo di carica.

COLLEGAMENTO ALLA RETE

- Il caricabatterie deve essere collegato esclusivamente ad un sistema di alimentazione con conduttore di neutro collegato a terra. Controllare che la tensione di rete sia equivalente alla tensione di funzionamento.
- La linea di alimentazione dovrà essere dotata di sistemi di protezione, quali fusibili o interruttori automatici, sufficienti per sopportare l'assorbimento massimo dell'apparecchio (secondo targa dati).
- Il collegamento alla rete è da effettuarsi con apposito cavo.
- Eventuali prolunghie del cavo di alimentazione devono avere una sezione adeguata e comunque mai inferiore a quella

del cavo fornito.

4. FUNZIONAMENTO

PREPARAZIONE PER LA CARICA

NB: Prima di procedere alla carica, verificare che la capacità delle batterie (Ah) che si intendono sottoporre a carica non sia inferiore a quella indicata in targa (C min).

Eeguire le istruzioni seguendo scrupolosamente l'ordine sotto riportato.

- Rimuovere i coperchi della batteria (se presenti), così che i gas che si producono durante la carica possano fuoriuscire.
- Controllare che il livello dell'elettrolita ricopra le piastre delle batterie; se queste risultassero scoperte aggiungere acqua distillata fino a sommergerle di 5 -10 mm.



ATTENZIONE! PRESTARE LA MASSIMA CAUTELA DURANTE QUESTA OPERAZIONE IN QUANTO L'ELETTROLITA È UN ACIDO ALTAMENTE CORROSIVO.

- Verificare che il caricabatteria sia scollegato dalla rete.
- Verificare la polarità dei morsetti della batteria: positivo (simbolo +) e negativo (simbolo -).
NOTA: se i simboli non si distinguono si ricorda che il morsetto positivo è quello non collegato al telaio della macchina.
- Collegare la pinza di carica di colore rosso al morsetto positivo della batteria (simbolo +).
- Collegare la pinza di carica di colore nero al telaio della macchina, lontano dalla batteria e dal condotto del carburante.

NOTA: se la batteria non è installata in macchina, collegarsi direttamente al morsetto negativo della batteria (simbolo -).

5. CONSIGLI UTILI

- Pulire i morsetti positivo e negativo da possibili incrostazioni di ossido in modo da assicurare un buon contatto delle pinze.
- Se la batteria con cui si intende usare questo caricabatterie è permanentemente inserita su un veicolo, consultare anche il manuale istruzioni e/o di manutenzione del veicolo alla voce "IMPIANTO ELETTRICO" o "MANUTENZIONE". Preferibilmente scollegare, prima di procedere alla carica, il cavo positivo facente parte dell'impianto elettrico del veicolo.

(FR)



ATTENTION: LIRE ATTENTIVEMENT LE MANUEL D'INSTRUCTIONS AVANT TOUTE UTILISATION DU CHARGEUR DE BATTERIE !

1. INSTRUCTIONS GÉNÉRALES DE SÉCURITÉ POUR L'UTILISATION DE CE CHARGEUR DE BATTERIE



- Les batteries dégagent des gaz explosifs durant la charge, éviter toute flamme ou étincelle, NE PAS FUMER.
- Positionner les batteries sous charge dans un endroit aéré.



- **Fournir aux personnes dont l'expérience est insuffisante des informations adéquates avant toute utilisation de l'appareil.**
- **L'appareil peut être utilisé par des enfants d'un âge non inférieur à 8 ans et par des personnes ayant des capacités physiques, sensorielles ou mentales réduites, ou sans expérience ou connaissance nécessaire, à condition que ce soit sous surveillance ou après que ces mêmes personnes aient reçu des instructions concernant l'utilisation sûre de l'appareil et concernant la compréhension des dangers inhérents à celui-ci.**
- **Les enfants ne doivent pas jouer avec l'appareil.**
- **Le nettoyage et l'entretien destinés à être effectués par l'utilisateur ne doivent pas être effectués par des enfants sans surveillance.**
- Débrancher le câble d'alimentation avant de connecter ou de déconnecter les câbles de charge de la batterie.
- Ne pas connecter ou déconnecter les pinces de la batterie quand le chargeur est en fonctionnement.
- N'utiliser sous aucun prétexte le chargeur de batterie à l'intérieur du véhicule ou dans le coffre.
- Remplacer exclusivement le câble d'alimentation par un câble original.
- Si le câble d'alimentation est endommagé, il doit être substitué par le constructeur ou par son service d'assistance technique ou, quoi qu'il en soit, par une personne ayant une qualification similaire, de façon à prévenir tout risque.
- Ne pas utiliser le chargeur de batterie pour recharger des batteries non rechargeables.
- Vérifier que la tension d'alimentation disponible correspond à celle indiquée sur la plaquette signalétique du chargeur de batterie.
- Pour ne pas endommager la partie électronique des véhicules, lire, conserver et respecter scrupuleusement les avertissements des constructeurs des véhicules, en cas d'utilisation du chargeur de batterie tant pour la recharge que pour le démarrage ces prescriptions s'appliquent également aux indications fournies par le

constructeur des batteries.

- Ce chargeur de batterie comporte des parties, comme interrupteurs ou relais, risquant de provoquer des arcs électriques ou des étincelles par conséquent, en cas d'utilisation dans un garage ou un lieu du même type, placer le chargeur de batterie dans un local ou une protection adéquats.
- Les interventions de réparation ou d'entretien à l'intérieur du chargeur de batterie doivent exclusivement être effectuées par un personnel qualifié.



TOUJOURS DÉBRANCHER LE CORDON D'ALIMENTATION DE LA PRISE ÉLECTRIQUE AVANT TOUTE INTERVENTION SUR LE CHARGEUR DE BATTERIES.

2. INTRODUCTION ET DESCRIPTION GÉNÉRALE

- Ce chargeur permet de charger des batteries au plomb à électrolyte libre, hermétiques et au lithium utilisées sur les véhicules à moteur (essence et diesel), motocycles, bateaux, etc.
 - Accumulateurs rechargeables en fonction de la tension de sortie disponible : 6V, 12V et 24V (en fonction de la plaque signalétique).
 - Ce chargeur peut, en fonction du modèle, peut être alimenté en 230V 50/60Hz ou en 110V 50/60Hz (en fonction de la plaque signalétique) monophasé.
- Le courant et la tension de charge fournis par l'appareil sont à contrôle électronique et suivent la courbe de charge IU ou U.

- Équipements de série :
 - L'appareil permet de brancher en sortie différentes typologies de câbles pour la recharge des batteries :
 - câbles munis d'œillets;
 - câbles munis de pinces.

3. INSTALLATION

POSITIONNEMENT DU CHARGEUR DE BATTERIES

- Durant son fonctionnement, placer le chargeur de batteries de façon stable.
- Éviter de soulever le chargeur de batteries par le câble d'alimentation ou par le câble de chargement.

BRANCHEMENT AU RÉSEAU

- Le chargeur de batteries doit être branché exclusivement à un système d'alimentation avec un conducteur de neutre branché à la terre.
Contrôler que la tension de réseau est équivalente à la tension de fonctionnement.
- La ligne d'alimentation devra être équipée de systèmes de protection, comme des fusibles ou des interrupteurs automatiques, suffisants pour supporter l'absorption maximale de l'appareil (en fonction de la plaque signalétique).
- Le branchement au réseau doit être effectué avec le câble prévu à cet effet.
- Les éventuelles rallonges du câble d'alimentation doivent avoir une section adéquate et, quoi qu'il en soit, jamais inférieure à celle du câble fourni.

4. FONCTIONNEMENT

PRÉPARATION POUR LA CHARGE

NB : Avant de procéder à la charge, vérifier que la capacité des batteries (Ah) que l'on entend soumettre à la charge n'est pas inférieure à celle

indiquée sur la plaquette (C min).

Exécuter les instructions en suivant scrupuleusement l'ordre reporté ci-dessous.

- Remettre les couvercles de la batterie (s'ils sont présents), de façon à ce que les gaz qui se produisent durant la charge puissent sortir.
- Contrôler que le niveau de l'électrolyte recouvre les plaques des batteries ; si celles-ci sont découvertes, ajouter de l'eau distillée jusqu'à ce qu'elles soient submergées de 5-10 mm.



ATTENTION ! PRÊTER LA PLUS GRANDE ATTENTION DURANT CETTE OPÉRATION CAR L'ÉLECTROLYTE EST UN ACIDE HAUTEMENT CORROSIF.

- Vérifier que le chargeur de batteries est débranché du réseau.
 - Vérifier la polarité des bornes de la batterie : positive (symbole +) et négative (symbole -).
NOTE : si les symboles ne se distinguent pas, nous rappelons que la borne positive est celle qui n'est pas branchée au châssis de la machine.
 - Brancher la pince de charge de couleur rouge à la borne positive de la batterie (symbole +).
 - Brancher la pince de charge de couleur noire au châssis de la voiture, loin de la batterie et du conduit du carburant.
- NOTE : si la batterie n'est pas installée sur la voiture, se brancher directement à la borne négative de la batterie (symbole -).

5. CONSEILS UTILES

- Nettoyer les bornes positives et négatives des oxydations éventuelles de façon à garantir un contact parfait des pinces.
- Si la batterie avec laquelle doit être utilisé ce chargeur de batterie est insérée de façon permanente sur un véhicule, se reporter également au manuel d'instructions et d'entretien du véhicule au chapitre "INSTALLATION ÉLECTRIQUE" ou "ENTRETIEN".
Avant de procéder à la charge, déconnecter si possible le câble positif faisant partie de l'installation électrique du véhicule.

(ES)



ATENCIÓN: ANTES DE UTILIZAR EL CARGADOR DE BATERÍAS LEER ATENTAMENTE EL MANUAL DE INSTRUCCIONES.

1. SEGURIDAD GENERAL PARA EL USO DE ESTE CARGADOR DE BATERÍAS



- Durante la carga, las baterías emanan gases explosivos, evitar que se formen llamas o chispas. NO FUMAR.
- Colocar las baterías en carga en un lugar aireado.



- Las personas sin experiencia deben recibir la formación adecuada antes de utilizar el aparato.
- El aparato puede ser utilizado por niños de más de 8 años y por personas

con capacidades físicas, sensoriales o mentales reducidas, sin experiencia o sin los conocimientos necesarios siempre que estén bajo vigilancia o que hayan recibido instrucciones sobre un uso seguro del aparato y comprendan los peligros inherentes al mismo.

- Los niños no deben jugar con el aparato.
- La limpieza y el mantenimiento destinados a ser realizados por el usuario no deben ser llevados a cabo por niños sin vigilancia.
- Desenchufar el cable de alimentación de la red antes de conectar o desconectar los cables de carga de la batería.
- No conectar o desconectar las pinzas a la batería cuando el cargador esté en funcionamiento.
- No utilizar el cargador de baterías por ningún motivo en el interior de un coche o en el capó.
- Sustituir el cable de alimentación sólo con un cable original.
- Si se ha dañado el cable de alimentación, debe ser sustituido por el fabricante o por su servicio de asistencia técnica o en cualquier caso por una persona con una cualificación similar, para evitar cualquier riesgo.
- No utilizar al cargador de baterías para recargar baterías no recargables.
- Controlar que la tensión de alimentación disponible corresponda con la indicada en la chapa de datos del cargador de baterías.
- Para no dañar la electrónica de los vehículos, leer, conservar, respetar escrupulosamente las advertencias de los fabricantes de los mismos vehículos, cuando se utilice el cargador de baterías tanto en carga como en arranque; lo mismo vale para las indicaciones ofrecidas por el fabricante de las baterías.
- Este cargador de baterías tiene interruptores o relés que pueden provocar arcos o chispas; por lo tanto, si se usa en un garaje o en ambiente similar, deberemos colocarlo en un local o en una parte protegida adecuados para ello.
- Las intervenciones de reparación o mantenimiento en el interior del cargador de baterías deben ser efectuadas sólo por profesionales.



DESCONECTAR SIEMPRE EL CABLE DE ALIMENTACIÓN DE LA RED ANTES DE EFECTUAR CUALQUIER INTERVENCIÓN DE MANTENIMIENTO EN EL CARGADOR DE BATERÍAS.

2. INTRODUCCIÓN Y DESCRIPCIÓN GENERAL

- Este cargador de baterías permite la carga de baterías al plomo de electrolito libre, herméticas y al litio usadas en vehículos a motor (gasolina o diésel), motos, embarcaciones, etc.
- Acumuladores recargables en función de la tensión de salida disponible: 6V, 12V y 24V (dependiendo de la placa de datos).
- Este cargador de baterías, dependiendo del modelo, puede tener una alimentación 230V 50/60Hz o 110V 50/60Hz (dependiendo de la placa de datos) monofásica. La corriente y la tensión de carga suministradas por el aparato están controladas electrónicamente y siguen la curva de carga IU o U.
- Incluye:
 - El aparato permite conectar en salida diferentes tipos de cables para la recarga de las baterías:
 - cables con argollas;

- cables con pinzas.

3. INSTALACIÓN

UBICACIÓN DEL CARGADOR DE BATERÍAS

- Durante el funcionamiento posicionar el cargador de baterías de forma estable.
- Evitar levantar el cargador de baterías a través del cable de alimentación o a través del cable de carga.

CONEXIÓN A LA RED

- El cargador de baterías tiene que conectarse exclusivamente a un sistema de alimentación con un conductor de neutro conectado a tierra. Controlar que la tensión eléctrica de red sea equivalente a la tensión eléctrica de funcionamiento.
- La línea de alimentación tendrá que equiparse con sistemas de protección, como fusibles o interruptores automáticos, con una capacidad suficiente para soportar la absorción máxima del equipo (dependiendo de la placa de datos).
- La conexión a la red tiene que realizarse con el cable correspondiente.
- Las posibles extensiones del cable de alimentación tienen que tener una sección adecuada y, en cualquier caso, no debe ser inferior a la del cable que se entrega.

4. FUNCIONAMIENTO

PREPARACIÓN PARA LA CARGA

CUIDADO: Antes de proceder a la carga, comprobar que la capacidad de las baterías (Ah) que se desean someter a carga no sea inferior con respecto a la que se indica en la placa (C mín).

Observar las instrucciones siguiendo escrupulosamente el orden que se indica a continuación.

- Quitar las tapas de las baterías (si están presentes), de forma que los gases que se producen durante la carga puedan salir.
- Controlar que el nivel del electrolito cubra las placas de las baterías; si éstas resultaran descubiertas, añadir agua destilada hasta sumergir de 5-10 mm.



¡ATENCIÓN! PRESTAR LA MÁXIMA CAUTELA DURANTE ESTA OPERACIÓN, YA QUE EL ELECTROLITO ES UN ÁCIDO ALTAMENTE CORROSIVO.

- Comprobar que el cargador de baterías se encuentre desconectado de la red.
- Controlar la polaridad de los bornes de la batería: positivo (símbolo +) y negativo (símbolo -).
NOTA: si los símbolos no se distinguen se recuerda que el borne positivo es el que no se ha conectado al bastidor del vehículo.
- Conectar la pinza de carga de color rojo al borne positivo de la batería (símbolo +).
- Conectar la pinza de carga de color negro al bastidor de la máquina, lejos de la batería y del conducto del combustible.
NOTA: Si la batería no se ha instalado en la máquina, conectarse directamente al borne negativo de la batería (símbolo -).

5. CONSEJOS ÚTILES

- Limpiar los terminales positivo y negativo de posibles incrustaciones de óxido, de manera que se asegure un buen contacto de las pinzas.

- Si la batería con la cual se quiere utilizar este cargador de baterías está permanentemente colocada en un vehículo, consultar también en el manual de instrucciones o de mantenimiento del vehículo el capítulo "INSTALACIÓN ELÉCTRICA" o "MANTENIMIENTO". Es mejor separar, antes de pasar a la carga, el cable positivo de la instalación eléctrica del vehículo.

(DE)



ACHTUNG: VOR DER BENUTZUNG DES LADEGERÄTES LESEN SIE BITTE AUFMERKSAM DIE BETRIEBSANLEITUNG!

1. ALLGEMEINE SICHERHEITSVORSCHRIFTEN FÜR DIE NUTZUNG DIESES LADEGERÄTES



- Während des Ladens entweichen aus der Batterie Explosivgase, vermeiden Sie daher offene Flammen oder Funkenflug. NICHT RAUCHEN.
- Stellen Sie die Batterien während des Ladevorganges an einen gut belüfteten Ort.



- **Unerfahrene Personen müssen vor dem Gebrauch des Gerätes in angemessener Weise unterwiesen werden.**
- **Das Gerät darf von Kindern ab 8 Jahren und von Personen mit eingeschränkten körperlichen, sensorischen oder mentalen Fähigkeiten bzw. ohne Erfahrung oder der notwendigen Kenntnis verwendet werden, wenn vorausgesetzt ist, dass dies unter Aufsicht erfolgt oder nachdem sie entsprechende Anweisungen für den sicheren Gebrauch des Geräts erhalten und die Gefahren, die mit ihm einhergehen, verstanden haben.**
- **Kindern ist das Spielen mit dem Gerät untersagt.**
- **Die Reinigung und die Wartung, die dem Anwender obliegen, dürfen von Kindern nur unter Aufsicht durchgeführt werden.**
- Ziehen Sie das Netzkabel aus der Steckdose, bevor Sie die Ladungskabel der Batterie anschliessen oder ausstecken.
- Nicht die Zangen an die Batterie einstecken oder ausstecken bei funktionierendem Ladegerät.
- Auf keinen Fall soll das Gerät im Inneren des Autos oder der Motorhaube benutzt werden.
- Ersetzen Sie das Netzkabel nur durch ein Originalkabel.
- Sollte das Versorgungskabel beschädigt sein, muss dieses durch den Hersteller oder den technischen Kundendienst bzw. durch eine hierfür qualifizierte Person ausgetauscht werden, um jedem Risiko entgegenzuwirken.
- Verwenden Sie das Ladegerät nicht für die Ladung von Batterien, die nicht nachgeladen werden können.
- Prüfen Sie, ob die verfügbare Versorgungsspannung der Angabe auf dem Datenschild des Ladegerätes entspricht.
- Um die Fahrzeugelektronik nicht zu beschädigen, lesen Sie die

Betriebsanleitungen des Fahrzeugherstellers durch, bewahren sie auf und beachten sie strikt, wenn das Ladegerät zum Laden oder Starten benutzt wird. Das Gleiche gilt für die Anleitungen des Batterieherstellers.

- Dieses Ladegerät enthält Teile wie z. B. einen Abschalter oder ein Relais, die Funken oder Lichtbögen erzeugen können. Deswegen sollte das Gerät, wenn es in einer Garage oder an einem ähnlichen Ort verwendet wird, an einer geschützten Stelle unter Aufsicht in Betrieb genommen werden.
- Reparatur- oder Instandhaltungsarbeiten im Inneren des Gerätes dürfen nur von geschultem Personal vorgenommen werden.



DAS VERSORUNGSKABEL IMMER VOM NETZ NEHMEN BEVOR IRGENDNE ART VON WARTUNG AM BATTERIELADEGERÄT DURCHFÜHRT WIRD.

2. EINFÜHRUNG UND ALLGEMEINE BESCHREIBUNG

- Dieses Batterieladegerät ermöglicht das Laden von Bleibatterien mit freiem Elektrolyt, von hermetisch dichten Batterien und Lithiumbatterien, die beispielsweise bei Kraftfahrzeugen (Benzin und Diesel), Motorrädern oder Booten verwendet werden.
- Basierend auf der verfügbaren Ausgangsspannung aufladbare Akkumulatoren: 6V, 12V und 24V (gemäß Typenschild).
- Dieses Batterieladegerät kann je nach Modell mit 230V 50/60Hz oder 110V 50/60Hz (gemäß Typenschild) einphasig versorgt werden. Der vom Gerät abgegebene Ladestrom und die abgegebene Ladespannung werden elektronisch gesteuert und folgen der Ladekurve IU oder U.
- Grundausstattung:
 - Das Gerät ermöglicht den Anschluss verschiedener Kabeltypen am Ausgang zum Aufladen der Batterien:
 - Ösenkabel;
 - Zangenkabel.

3. INSTALLATION AUFSTELLUNG DES BATTERIELADEGERÄTES

- Während des Betriebes ist das Batterieladegerät stabil zu positionieren.
- Zu vermeiden ist das Anheben des Batterieladegerätes am Versorgungs- oder Ladekabel.

ANSCHLUSS AN DAS STROMVERSORGUNGSNETZ

- Das Batterieladegerät darf ausschließlich an eine Versorgungsanlage mit Neutralleiter und Erdung angeschlossen werden. Prüfen Sie, ob die Netzspannung der Betriebsspannung entspricht.
- Die Versorgungsleitung muss mit Schutzsystemen wie Schmelzsicherungen oder Leistungsschaltern ausgestattet sein, die der maximalen Aufnahme des Gerätes standhalten (gemäß Typenschild).
- Der Netzanschluss ist mit dem passenden Kabel vorzunehmen.
- Mögliche Verlängerungen des Versorgungskabels müssen einen sachgerechten Querschnitt haben, der in keinem Fall geringer sein darf als der des im Lieferumfang enthaltenen Kabels.

4. FUNKTIONSWEISE

VORBEREITUNG ZUM LADEN

Anmerkung: Vor dem Laden ist zu prüfen, ob die Batteriekapazität (Ah), auf die geladen werden soll, nicht unter dem Wert auf dem Typenschild liegt (C min).

Die Anleitung ist - in der nachstehenden Reihenfolge - genau zu befolgen.

- Vorhandene Abdeckungen der Batterie sind zu entfernen, damit die beim Laden entstehenden Gase entweichen können.
- Prüfen Sie, ob das Elektrolyt so hoch steht, dass die Batterieplatten bedeckt sind. Sollten diese freiliegen, ist destilliertes Wasser nachzufüllen, bis die Platten von etwa 5 - 10 mm Wasser bedeckt sind.



ACHTUNG! WÄHREND DIESES VORGANGS IST HÖCHSTE VORSICHT GEBOTEN, WEIL DAS ELEKTROLYT EINE STARK ÄTZENDE SÄURE IST.

- Prüfen Sie, ob das Batterieladegerät vom Netz getrennt ist.
- Prüfen Sie die Polung der Batterieklemmen: Pluspol (Symbol +) und Minuspol (Symbol -). ANMERKUNG: Wenn die Symbole nicht erkennbar sind, sei daran erinnert, dass die Plusklemme die Klemme ist, die nicht mit dem Fahrgestell des Fahrzeugs verbunden ist.
- Die rote Ladezange an die Plusklemme der Batterie (Symbol +) anschließen.
- Die schwarze Ladeklemme, fern der Batterie und der Treibstoffleitung, an das Fahrgestell des Fahrzeugs anschließen. ANMERKUNG: Wenn die Batterie nicht in das Fahrzeug eingebaut ist, ist die direkte Verbindung zur Minusklemme der Batterie (Symbol -) herzustellen.

5. NÜTZLICHE HINWEISE

- Säubern Sie die Plus- und Minusklemmen von möglichen Oxidationsablagerungen, damit immer ein guter Kontakt mit den Masseklemmen herrscht.
- Wenn die Batterie, mit der man das Ladegerät betreiben will, ständig an ein Fahrzeug angeschlossen ist, beachten Sie auch die Betriebs- und Wartungsanleitung des Fahrzeugs, besonders die Punkte "ELEKTRISCHE ANLAGE" oder "WARTUNG". Vor dem Laden entfernen Sie möglichst das Pluskabel, das zur elektrischen Anlage des Fahrzeugs gehört.

(RU)



ВНИМАНИЕ: ПЕРЕД ИСПОЛЬЗОВАНИЕМ ЗАРЯДНОГО АККУМУЛЯТОРНОЙ БАТАРЕИ ВНИМАТЕЛЬНО ПРОЧИТАТЬ РАБОЧЕЕ РУКОВОДСТВО!

1. ОБЩАЯ БЕЗОПАСНОСТЬ ПРИ ИСПОЛЬЗОВАНИИ ДАННОГО ЗАРЯДНОГО УСТРОЙСТВА



- Во время зарядки из аккумуляторной батареи выходит взрывчатый газ, избегать образования пламени и искрения. НЕ КУРИТЬ.

- Установить аккумуляторную батарею во время зарядки в хорошо проветриваемое место.



- **Неопытный персонал должен пройти соответствующее обучение перед использованием оборудования.**

- **Аппарат разрешается использовать детям в возрасте от 8 лет и лицам с ограниченными физическими, сенсорными или умственными способностями, или без опыта или необходимых знаний при условии, что они находятся под присмотром либо прошли инструктаж относительно безопасного использования аппарата и понимают связанные с ним риски.**

- **Детям запрещается играть с аппаратом.**
- **Детям без присмотра запрещается осуществлять чистку и предусмотренное техобслуживание.**

- Отсоединить от сети кабель питания перед тем, как соединять и отсоединять зарядный кабель от аккумуляторной батареи.

- Не присоединять и не отсоединять зажимы от батареи при работающем зарядном устройстве батареи.

- Никогда не использовать зарядное устройство батареи внутри салона автомобиля или внутри капота.

- Заменять кабель питания только на оригинальный кабель.

- В случае повреждения кабеля питания, его замену необходимо доверить специалисту изготовителя или сервисного центра, либо другому лицу, обладающему аналогичной квалификацией, чтобы устранить все возможные риски.

- Не использовать зарядное устройство батареи для зарядки аккумуляторных батарей не заряжаемого типа.

- Проверить, что имеющееся напряжение питания соответствует указанному на табличке с характеристиками зарядного устройства батареи.

- Для того, чтобы не повредить электронную систему автомобиля, прочитать, хранить и тщательно выполнять инструкции, предоставленные производителем транспортного средства, когда зарядное устройство батареи используется как для зарядки, так и для пуска; то же относится к инструкциям, предоставленным производителем батареи.

- Это зарядное устройство батареи включает такие части, как переключатели и реле, могущие спровоцировать дугу и искры; поэтому, если вы используете устройство в гараже и подобном помещении, поместить зарядное устройство аккумуляторной батареи в место, подходящее для его хранения.

- Ремонт и техобслуживание внутренней части зарядного устройства батареи должны выполняться только опытным персоналом.

- **ВСЕГДА ОТКЛЮЧАЙТЕ КАБЕЛЬ ПИТАНИЯ ОТ СЕТИ ПЕРЕД ВЫПОЛНЕНИЕМ ЛЮБЫХ РАБОТ ПО ТЕХОБСЛУЖИВАНИЮ ЗАРЯДНОГО УСТРОЙСТВА.**

2. ВВЕДЕНИЕ И ОБЩЕЕ ОПИСАНИЕ

- Это зарядное устройство позволяет

- заряжать свинцово-кислотные аккумуляторы с жидким электролитом, герметичные и литиевые аккумуляторы, используемые в транспортных средствах с бензиновым или дизельным двигателем, мотоциклах, лодках и др.
- Возможна зарядка аккумуляторов со следующим выходным напряжением: 6 В, 12 В и 24 В (согласно табличке с техническими данными).
- Это зарядное устройство, в зависимости от модели, может питаться от однофазной электросети с напряжением 230 В 50/60 Гц или 110 В 50/60 Гц (согласно табличке с техническими данными).

Зарядный ток и напряжение, подаваемые устройством, контролируются электронно и следуют кривой зарядки IU или U.

- Стандартная комплектация:
 - Устройство позволяет подключать к выходу различные типы кабелей для зарядки аккумуляторов:
 - кабели с ушком;
 - кабели с зажимом.

3. УСТАНОВКА

РАСПОЛОЖЕНИЕ ЗАРЯДНОГО УСТРОЙСТВА

- Во время работы установите зарядное устройство в стабильное положение.
- Не поднимайте зарядное устройство за кабель питания или зарядный кабель.

ПОДСОЕДИНЕНИЕ К СЕТИ

- Зарядное устройство разрешается подключать только к системе питания с заземленным нейтральным проводом. Убедитесь, что напряжение электросети соответствует рабочему напряжению.
- Линия питания должна быть оснащена защитными системами, такими как предохранители или автоматические выключатели, способными выдержать максимальный ток, потребляемый оборудованием (согласно табличке с техническими данными).
- Для подключения к сети необходимо использовать специальный кабель.
- В случае использования удлинителей, поперечное сечение проводников должно быть соответствующим и ни в коем случае оно не должно быть меньше поперечного сечения прилагаемого кабеля.

4. РАБОТА

ПОДГОТОВКА К ЗАРЯДКЕ

Примечание: Перед тем как начать зарядку, убедитесь, что емкость аккумуляторов (А-ч), которые предполагается зарядить, не ниже значения, указанного на табличке технических данных (С min).

Следуйте указаниям, строго соблюдая указанный порядок.

- Снимите крышки аккумулятора (если они имеются), чтобы газы, образующиеся во время зарядки, могли выйти наружу.
- Убедитесь, что электролит покрывает пластины аккумулятора; если они не покрыты, добавьте дистиллированную воду, чтобы погрузить пластины на 5–10 мм.

ВНИМАНИЕ! ВО ВРЕМЯ ЭТОЙ ОПЕРАЦИИ СОБЛЮДАЙТЕ ОСОБУЮ ОСТОРОЖНОСТЬ, ПОСКОЛЬКУ ЭЛЕКТРОЛИТ ЯВЛЯЕТСЯ ОЧЕНЬ ЕДКОЙ КИСЛОТОЙ.



- Убедитесь, что зарядное устройство отсоединено от электросети.
 - Проверьте полярность клемм аккумулятора: положительная (символ +) и отрицательная (символ -).
- ПРИМЕЧАНИЕ: если символы не удастся различить, напоминаем, что положительная клемма – это клемма, которая не подключена к шасси автомобиля.
- Подсоедините красный зарядный зажим к положительной клемме аккумулятора (символ +).
 - Подсоедините зарядный зажим черного цвета к шасси автомобиля, вдали от аккумулятора и топливопровода.
- ПРИМЕЧАНИЕ: Если аккумулятор не установлен в автомобиль, подсоедините его непосредственно к отрицательной клемме аккумулятора (символ -).

5. ПОЛЕЗНЫЕ СОВЕТЫ

- Очищать положительные и отрицательные клеммы от налета окисления, чтобы обеспечить хороший контакт зажимов.
- Если батарея, с которой Вы намерены использовать это зарядное устройство батареи, постоянно установлена на транспортное средство, проконсультироваться также с рабочими инструкциями и/или инструкциями по техобслуживанию транспортного средства, прочитав главы "ЭЛЕКТРИЧЕСКАЯ СИСТЕМА" или "ТЕХОБСЛУЖИВАНИЕ". Предпочтительно отсоединять перед тем, как производить зарядку, положительный кабель, являющийся частью электрической системы транспортного средства.

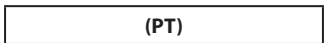

ATENÇÃO: ANTES DE UTILIZAR O CARREGADOR LER O MANUAL DE INSTRUÇÕES ATENTAMENTE!

1. SEGURANÇA GERAL PARA O USO DESTES CARREGADOR DE BATERIAS



- Durante o carregamento as baterias emanam gases explosivos, evitar que se formem chamas e faíscas. **NÃO FUMAR.**
- Colocar as baterias que estão sendo carregadas num lugar ventilado.



- **As pessoas que não têm experiência devem ser instruídas oportunamente antes de utilizar o aparelho.**
- **O aparelho pode ser usado por crianças de idade não inferior a 8 anos e por pessoas com reduzidas capacidades físicas, sensoriais ou mentais, ou sem a experiência ou conhecimentos necessários, desde que sob vigilância ou depois de receberem instruções relativas ao uso seguro do aparelho e à compreensão dos perigos associados ao mesmo.**
- **As crianças não devem brincar com o aparelho.**

- **A limpeza e a manutenção destinadas a ser efetuadas pelo utilizador não devem ser efetuadas por crianças sem vigilância.**

- Desligar o cabo eléctrico da rede antes de ligar ou desligar os cabos de carga da bateria.
- Não prender nem desprender as pinças à bateria com o carregador de baterias funcionando.
- Não usar de maneira nenhuma o carregador de baterias dentro de um automóvel ou do capô.
- Substituir o cabo eléctrico somente com um cabo original.
- Se o cabo de alimentação estiver danificado, deve ser substituído pelo fabricante ou pelo seu serviço de assistência técnica ou por uma pessoa com qualificações semelhantes, de forma a prevenir qualquer risco.
- Não usar o carregador de baterias para recarregar baterias do tipo que não podem ser recarregadas.
- Verificar que a tensão de alimentação disponível seja correspondente àquela indicada na placa de dados do carregador de baterias.
- Para não danificar a electrónica dos veículos, ler, guardar, respeitar rigorosamente os avisos fornecidos pelos fabricantes dos próprios veículos, quando se usa o carregador de baterias tanto sob carga como em arranque; o mesmo vale para as indicações fornecidas pelo fabricante de baterias.
- Este carregador de baterias contém partes, tais como interruptores ou relés, que podem provocar arcos ou faíscas; portanto se for usado numa garagem ou em ambiente semelhante, colocar o carregador de baterias num lugar ou caixa apropriada para tal fim.
- Operações de reparação ou de manutenção no interior do carregador de baterias devem ser efectuadas somente por profissionais especializados.



DESINSERIR SEMPRE O CABO DE ALIMENTAÇÃO DA REDE ANTES DE EFETUAR QUALQUER INTERVENÇÃO DE MANUTENÇÃO NO CARREGADOR DE BATERIA.

2. INTRODUÇÃO E DESCRIÇÃO GERAL

- Este carregador de bateria permite carregar baterias de chumbo com eletrólito livre, herméticas e de lítio usadas em veículos a motor (gasolina e gasóleo), motociclos, embarcações, etc.
- Acumuladores recarregáveis em função da tensão de saída disponível: 6V, 12V e 24V (de acordo com a placa de dados).
- Este carregador de bateria, conforme o modelo, está disponível com alimentação 230V 50/60Hz ou 110V 50/60Hz (de acordo com a placa de dados) monofásica.
A corrente e a tensão de carga fornecidas pelo aparelho são controladas eletronicamente e seguem a curva de carga IU ou U.
- Fornecimento de série:
 - O aparelho permite ligar em saída vários tipos de cabos para recarregar baterias:
 - cabos com olhais;
 - cabos com pinças.

3. INSTALAÇÃO

LOCALIZAÇÃO DO CARREGADOR DE BATERIA

- Durante o funcionamento, posicionar o carregador de bateria de forma estável.
- Evitar levantar o carregador de bateria através

do cabo de alimentação ou do cabo de carga.

LIGAÇÃO À REDE

- O carregador de bateria deve ser ligado exclusivamente a um sistema de alimentação com condutor de neutro ligado à terra. Verificar se a tensão de rede é equivalente à tensão de funcionamento.
- A linha de alimentação deverá ser equipada com sistemas de proteção, como fusíveis ou interruptores automáticos, suficientes para suportar a absorção máxima do aparelho (de acordo com a placa de dados).
- A ligação à rede deve ser efetuada com um cabo apropriado.
- Eventuais extensões do cabo de alimentação devem ter uma secção adequada e de qualquer forma nunca inferior àquela do cabo fornecido.

4. FUNCIONAMENTO

PREPARAÇÃO PARA A CARGA

OBS.: Antes de efetuar a carga, verifique que a capacidade das baterias (Ah) que se quer colocar em carga não é inferior à indicada na placa de dados (C min).

As instruções devem ser seguidas rigorosamente segundo a ordem indicada abaixo.

- Remova as tampas da bateria (se presentes), de forma que os gases que são produzidos durante a carga possam sair.
- Controle que o nível do eletrólito cubra as placas das baterias; se estas estiverem descobertas adicione água destilada até mergulhá-las de 5 – 10 mm.



ATENÇÃO! TOME O MÁXIMO CUIDADO DURANTE ESTA OPERAÇÃO POIS O ELETRÓLITO É UM ÁCIDO ALTAMENTE CORROSIVO.

- Verificar se o carregador de bateria está desligado da rede.
- Verificar a polaridade dos bornes da bateria: positivo (símbolo +) e negativo (símbolo -).
NOTA: se os símbolos não se distinguem lembra-se que o borne positivo é aquele não ligado no chassis do veículo.
- Ligar a pinça de carga de cor vermelha ao borne positivo da bateria (símbolo +).
- Ligar a pinça de carga de cor preta ao chassis do veículo, longe da bateria e da mangueira do combustível.
NOTA: se a bateria não estiver instalada no veículo, ligar diretamente ao borne negativo da bateria (símbolo -).

5. CONSELHOS ÚTEIS

- Limpar os bornes positivo e negativo de possíveis incrustações de óxido a fim de garantir um bom contacto das pinças.
- Se a bateria com a qual se quer usar este carregador de baterias estiver permanentemente inserida num veículo, consultar também o manual de instruções e/ou de manutenção do veículo no capítulo "INSTALAÇÃO ELÉCTRICA" ou "MANUTENÇÃO". É preferível desligar, antes de efectuar o carregamento, o cabo positivo que faz parte da instalação eléctrica do veículo.



OPGELET: VOORDAT MEN DE BATTERIJLADER GEBRUIKT, AANDACHTIG DE INSTRUCTIEHANDLEIDING LEZEN

1. ALGEMENE VEILIGHEID VOOR HET GEBRUIK VAN DEZE BATTERIJLADER



- Tijdens het opladen laten de batterijen explosief gas vrij, vermijd dat er zich vlammen en vonken vormen. NIET ROKEN.
- De op te laden batterijen op een verluchte plaats zetten.



- De niet ervaren personen moeten op een adequate manier opgeleid worden voordat ze het toestel gebruiken.
- Het apparaat kan worden gebruikt door kinderen vanaf 8 jaar en door personen met beperkte fysieke, zintuiglijke of mentale capaciteit, door personen zonder ervaring of de benodigde kennis, mits deze onder toezicht staan of nadat deze instructies hebben gekregen over een veilig gebruik van het apparaat en over het begrip van de gevaren die met het apparaat gepaard gaan.
- Kinderen mogen niet met het apparaat spelen.
- De reiniging en het onderhoud dat door de gebruiker moeten worden uitgevoerd, mogen niet worden uitgevoerd door kinderen die niet onder toezicht staan.
- De voedingskabel loskoppelen van het net voordat de kabels voor het opladen worden aangesloten op of losgekoppeld van de batterij.
- De tangen niet aansluiten op of loskoppelen van de batterij met de batterijlader in werking.
- De batterijlader geenszins gebruiken binnen in de auto of in de motorkap.
- De voedingskabel alleen vervangen met een originele kabel.
- Als het snoer is beschadigd, moet het worden vervangen door de fabrikant of diens technische dienst of in ieder geval door iemand met een dergelijke deskundigheid, om ieder risico te vermijden.
- De batterijlader niet gebruiken om niet heroplaadbare batterijen terug op te laden.
- Verifiëren of de beschikbare voedingsspanning overeenstemt met diegene die aangeduid staat op de plaat met de gegevens van de batterijlader.
- Teneinde de elektronica van de voertuigen niet te beschadigen, de waarschuwingen gegeven door de fabrikanten van de voertuigen zelf lezen, bewaren en zorgvuldig in acht nemen, wanneer men de batterijlader gebruikt zowel bij het opladen als bij de start; hetzelfde geldt voor de aanwijzingen gegeven door de fabrikant van de batterijen.
- Deze batterijlader bevat componenten, zoals schakelaars of relais, die bogen of vonken kunnen veroorzaken; bijgevolg, indien de batterijlader in een garage of in

een soortgelijke ruimte wordt gebruikt, moet men hem in een lokaal of in een omgeving plaatsen die speciaal voor dit doel bestemd is.

- Ingrepen van herstellingen of onderhoud aan de binnenkant van de batterijlader mogen alleen uitgevoerd worden door personeel met ervaring.



HAAL ALTIJD DE STEKKER UIT HET STOPCONTACT VOORDAT U ONDERHOUDSWERKZAAMHEDEN AAN DE ACCULADER UITVOERT.

2. INLEIDING EN ALGEMENE BESCHRIJVING

- Met deze acculader kunnen niet-gesloten loodaccu's met elektrolyt, gesloten accu's en lithiumaccu's worden opgeladen die worden gebruikt in motorvoertuigen (benzine en diesel), motoren, boten, enz.
- Oplaaadbare accu's op grond van de beschikbare uitgangsspanning: 6V, 12V en 24V (volgens het typeplaatje).
- Afhankelijk van het model, kan deze acculader een voeding hebben van 230V 50/60Hz of 110V 50/60Hz (volgens het typeplaatje), eenfasig.
- De laadstroom en -spanning die door het apparaat worden geleverd, zijn elektronisch bestuurd en volgen de laadkarakteristiek IU of U.
- Oorspronkelijke uitrusting:
 - In uitgang kunnen verschillende soorten kabels met het apparaat worden verbonden voor het opladen van de accu's:
 - kabels met oogjes;
 - kabels met klemmen.

3. INSTALLATIE PLAATS VAN DE ACCULADER

- Tijdens de werking de acculader stabiel neerzetten.
- De acculader niet optillen aan de voedingskabel of de laadkabel.

AANSLUITEN OP HET ELEKTRICITEITSNET

- De acculader mag uitsluitend worden aangesloten op een voedingssysteem waarvan de nulgeleider is aangesloten op de aarde. Controleren of de netspanning gelijk is aan de bedrijfsspanning.
- De voedingslijn moet voorzien zijn van beschermingssysteem, zoals zekeringen of automatische onderbrekers, die voldoende zijn voor het opnamemaximum van het apparaat (volgens het typeplaatje).
- De acculader moet op het elektriciteitsnet worden aangesloten met de speciale kabel.
- Eventuele verlengingen van de voedingskabel moeten een voldoende doorsnede hebben en mogen nooit dunner zijn dan de bijgeleverde kabel.

4. WERKING VOORBEREIDING OP HET LADEN

- N.B.: Voor het laden controleren of de capaciteit van de accu's (Ah) die moeten worden opgeladen niet lager is dan de capaciteit die staat aangegeven op het serieplaatje (C min). De instructies precies in de hieronder aangegeven volgorde uitvoeren.
- De deksels van de accu's (indien aanwezig) verwijderen, zodat de gassen die worden geproduceerd tijdens het laden naar buiten kunnen.

- Controleren of het elektrolytpeil de accuplaatjes bedekt; als deze bloot liggen, gedestilleerd water toevoegen totdat ze 5-10 mm onder staan.



OPGELET! WEES ZEER VOORZICHTIG TIJDENS DEZE HANDELING OMDAT ELEKTROLYT EEN STERK CORROSIEF ZUUR IS.

- Controleren of de acculader is losgekoppeld van het elektriciteitsnet.
- De polariteit van de accuklemmen controleren: positief (symbool +) en negatief (symbool -).
- LET OP: als de symbolen niet te onderscheiden zijn, onthoud dan dat de positieve klem is die niet is aangesloten op het chassis van de auto.
- De rode laadklem aansluiten op de positieve klem van de accu (symbool +).
- De zwarte laadklem aansluiten op het chassis van het voertuig, ver weg van de accu en de brandstofleiding.
- LET OP: als de accu niet in de auto is geïnstalleerd, direct aansluiten op de negatieve klem van de accu (symbool -).

5. NUTTIGE RAADGEVINGEN

- Mogelijke incrustaties van oxide wegnemen van de positieve en negatieve klemmen zodanig dat men een goed contact van de tangen garandeert.
- Indien de batterij waarmee men deze batterijlader wenst te gebruiken è permanent op een voertuig is aangesloten, moet men ook de handleiding instructie en/of onderhoud van het voertuig raadplegen op het punt "ELEKTRISCHE INSTALLATIE" of "ONDERHOUD". Bij voorkeur, vóór het opladen, de positieve kabel die deel uitmaakt van de elektrische installatie van het voertuig loskoppelen.

(EL)



ΠΡΟΣΟΧΗ: ΠΡΙΝ ΧΡΗΣΙΜΟΠΟΙΗΣΕΤΕ ΤΟ ΦΟΡΤΙΣΤΗ ΜΠΑΤΑΡΙΩΝ ΔΙΑΒΑΣΤΕ ΠΡΟΣΕΚΤΙΚΑ ΤΟ ΕΓΧΕΙΡΙΔΙΟ ΧΡΗΣΗΣ!

1. ΓΕΝΙΚΗ ΑΣΦΑΛΕΙΑ ΓΙΑ ΤΗ ΧΡΗΣΗ ΑΥΤΟΥ ΤΟΥ ΦΟΡΤΙΣΤΗ ΜΠΑΤΑΡΙΩΝ



- Κατά τη φόρτιση οι μπαταρίες εκπέμπουν εκρηκτικά αέρια, αποφεύγετε για αυτό να προκαλούνται φλόγες ή σπίθες. ΜΗΝ ΚΑΠΝΙΖΕΤΕ.
- Τοποθετείτε τις μπαταρίες που φορτίζονται σε αερισμένο χώρο.



- Άτομα χωρίς πείρα πρέπει να ενημερώνονται κατάλληλα πριν χρησιμοποιήσουν τη μηχανή.
- Η συσκευή μπορεί να χρησιμοποιηθεί από παιδιά ηλικίας όχι κατώτερης των 8 ετών και από άτομα με ελαττωμένες σωματικές, αισθητήριες ή διανοητικές ικανότητες, ή χωρίς πείρα ή κατάλληλη γνώση, εφόσον βρίσκονται υπό επίβλεψη ή έχουν λάβει οδηγίες για την ασφαλή χρήση της

συσκευής και την κατανόηση των σχετικών κινδύνων.

- Τα παιδιά δεν πρέπει να παίζουν με τη συσκευή.
- Ο καθαρισμός και η συντήρηση που πρέπει να γίνονται από το χρήστη, δεν πρέπει να εκτελούνται από παιδιά χωρίς επίβλεψη.
- Αποσυνδέετε το καλώδιο τροφοδοσίας από το δίκτυο πριν συνδέσετε ή αποσυνδέσετε τα καλώδια φόρτισης της μπαταρίας.
- Μην συνδέετε ή αποσυνδέετε τις λαβίδες στην μπαταρία με το φορτιστή σε λειτουργία.
- Κατά απόλυτο τρόπο μην χρησιμοποιείτε το φορτιστή μπαταριών μέσα σε αυτοκίνητο ή παρόμοιο αυτοκίνητο.
- Αντικαταστήστε το καλώδιο τροφοδοσίας μόνο με αυθεντικό καλώδιο.
- Αν το καλώδιο τροφοδοσίας έχει υποστεί βλάβη, πρέπει να αντικατασταθεί από τον κατασκευαστή ή από τεχνικό του σέρβις ή πάντως από άτομο με παρόμοια ειδικευση, ώστε να προλαμβάνονται όλοι οι κίνδυνοι.
- Μην χρησιμοποιήσετε το φορτιστή για τη φόρτιση μπαταριών του είδους που δεν φορτίζεται.
- Ελέγξτε ότι η διαθέσιμη τάση τροφοδοσίας αντιστοιχεί σε εκείνη που αναγράφεται στην τεχνική πινακίδα του φορτιστή.
- Για να μην βλάψετε το ηλεκτρονικό σύστημα των οχημάτων, διαβάστε, διατηρήστε και τηρήστε προσεκτικά τις ενδείξεις που χορηγούνται από τους κατασκευαστές των ίδιων οχημάτων όταν χρησιμοποιείται ο φορτιστής τόσο σε φόρτιση όσο σε εκκίνηση. Το ίδιο ισχύει για τις ενδείξεις που χορηγούνται από τον κατασκευαστή μπαταριών.
- Αυτός ο φορτιστής μπαταριών περιλαμβάνει μέρη, όπως διακόπτες ή ρελέ, που μπορούν να παράγουν τόξα ή σπίθες. Για αυτό αν χρησιμοποιείται σε αμαξοστάσιο ή παρόμοιο περιβάλλον, τοποθετήστε το φορτιστή σε κατάλληλο χώρο ή κατάλληλη θήκη.
- Επεμβάσεις επισκευής ή συντήρησης στο εσωτερικό του φορτιστή πρέπει να εκτελούνται μόνο από ειδικευμένο προσωπικό.
- **ΑΠΟΣΥΝΔΕΕΤΕ ΠΑΝΤΑ ΤΟ ΚΑΛΩΔΙΟ ΤΡΟΦΟΔΟΣΙΑΣ ΑΠΟ ΤΟ ΔΙΚΤΥΟ ΠΡΙΝ ΕΚΤΕΛΕΣΕΤΕ ΟΠΟΙΔΗΠΟΤΕ ΕΝΕΡΓΕΙΑ ΣΥΝΤΗΡΗΣΗΣ ΣΤΟ ΦΟΡΤΙΣΤΗ ΜΠΑΤΑΡΙΑΣ.**

2. ΕΙΣΑΓΩΓΗ ΚΑΙ ΓΕΝΙΚΗ ΠΕΡΙΓΡΑΦΗ

- Αυτός ο φορτιστής μπαταρίας επιτρέπει τη φόρτιση μπαταριών μολύβδου με ελεύθερο ηλεκτρολύτη, ερμητικά κλειστών και λιθίου, που χρησιμοποιούνται σε οχήματα με κινητήρα (βενζίνης και ντίζελ), μοτοσυκλέτες, σκάφη, κλπ.
- Επαναφορτιζόμενοι συσσωρευτές σε συνάρτηση με τη διαθέσιμη τάση εξόδου: 6V, 12V και 24V (σύμφωνα με πινακίδα χαρακτηριστικών).
- Αυτός ο φορτιστής μπαταρίας, ανάλογα με το μοντέλο, μπορεί να έχει τροφοδοσία 230V 50/60Hz ή 110V 50/60Hz (σύμφωνα με πινακίδα χαρακτηριστικών) μονοφασική. Το ρεύμα και η τάση φόρτισης που προμηθεύονται από τη συσκευή ελέγχονται ηλεκτρονικά και ακολουθούν την καμπύλη φόρτισης IU ή U.
- Βασικός εξοπλισμός:
 - Η συσκευή επιτρέπει να συνδεθούν στην έξοδο διάφορα είδη καλωδίων για την επαναφόρτιση των μπαταριών:

- καλώδια με θηλιές;
- καλώδια με τοιπιίδες.

3. ΕΓΚΑΤΑΣΤΑΣΗ

ΤΟΠΟΘΕΤΗΣΗ ΤΟΥ ΦΟΡΤΙΣΤΗ

- Κατά τη λειτουργία τοποθετήστε το φορτιστή ώστε να είναι σταθερός.
- Αποφεύγετε να σηκώνετε το φορτιστή μπαταρίας μέσω του καλωδίου τροφοδοσίας ή μέσω του καλωδίου φόρτισης.

ΣΥΝΔΕΣΗ ΣΤΟ ΔΙΚΤΥΟ

- Ο φορτιστής μπαταρίας πρέπει να συνδεθεί αποκλειστικά σε σύστημα τροφοδοσίας με γειωμένο ουδέτερο αγωγό. Ελέγξτε ότι η τάση δικτύου αντιστοιχεί στην τάση λειτουργίας.
- Η γραμμή τροφοδοσίας θα πρέπει να εφοδιαστεί με συστήματα προστασίας, όπως ασφάλειες τήξης ή αυτόματους διακόπτες, επαρκείς ώστε να αντέχουν τη μέγιστη απορρόφηση της συσκευής (σύμφωνα με πινακίδα χαρακτηριστικών).
- Η σύνδεση στο δίκτυο πρέπει να εκτελεστεί με ειδικό καλώδιο.
- Ενδεχόμενες προεκτάσεις του καλωδίου τροφοδοσίας πρέπει να έχουν κατάλληλη διατομή και πάντως ποτέ κατώτερη εκείνης του προμηθευμένου καλωδίου.

4. ΛΕΙΤΟΥΡΓΙΑ

ΠΡΟΕΤΟΙΜΑΣΙΑ ΓΙΑ ΤΗ ΦΟΡΤΙΣΗ

ΠΡΟΣΟΧΗ: Πριν εκτελέσετε τη φόρτιση, βεβαιωθείτε ότι η χωρητικότητα των μπαταριών (Ah) που θέλετε να φορτίσετε δεν είναι κατώτερη εκείνης που αναφέρεται στην τεχνική πινακίδα (C min).

Εκτελέστε τις οδηγίες ακολουθώντας αυστηρά την παρακάτω διάταξη.

- Αφαιρέστε τα καλύμματα της μπαταρίας (αν υπάρχουν), ώστε να απελευθερώνονται τα αέρια που παράγονται κατά τη φόρτιση.
- Ελέγξτε ότι η στάθμη του ηλεκτρολύτη καλύπτει τις πλάκες των μπαταριών. Αν αυτές προκύπτουν ακάλυπτες προσθέστε απεσταγμένο νερό μέχρι να βυθιστούν κατά 5 -10 mm.

ΠΡΟΣΟΧΗ! ΔΩΣΤΕ ΤΗ ΜΕΓΑΛΥΤΕΡΗ ΠΡΟΣΟΧΗ ΚΑΤΑ ΤΗΝ ΕΝΕΡΓΕΙΑ ΑΥΤΗ ΔΙΟΤΙ Ο ΗΛΕΚΤΡΟΛΥΤΗΣ ΕΙΝΑΙ ΟΞΥ ΑΚΡΩΣ ΔΙΑΒΡΩΤΙΚΟ.

- Βεβαιωθείτε ότι ο φορτιστής μπαταρίας είναι αποσυνδεδεμένος από το δίκτυο.
- Ελέγξτε την πολικότητα των ακροδεκτών της μπαταρίας: θετικό (σύμβολο +) και αρνητικό (σύμβολο -).
- ΣΗΜΕΙΩΣΗ:** αν δεν ξεχωρίζετε τα σύμβολα υπενθυμίζεται ότι ο θετικός ακροδέκτης είναι εκείνος που δεν συνδέεται στο πλαίσιο του οχήματος.
- Συνδέστε τη λαβίδα φορτίου κόκκινου χρώματος στο θετικό ακροδέκτη της μπαταρίας (σύμβολο +).
- Συνδέστε τη λαβίδα φορτίου μαύρου χρώματος στο πλαίσιο του οχήματος, μακριά από την μπαταρία και από τον αγωγό του καυσίμου.
- ΣΗΜΕΙΩΣΗ:** αν η μπαταρία δεν είναι εγκατεστημένη στο όχημα, συνδεθείτε κατευθείαν στον αρνητικό ακροδέκτη της μπαταρίας (σύμβολο -).

5. ΧΡΗΣΙΜΕΣ ΣΥΜΒΟΥΛΕΣ

- Καθαρίστε τους ακροδέκτες θετικό και αρνητικό από ενδεχόμενα εναποθέματα

οξειδίου ώστε να εξασφαλίζεται η καλή επαφή των λαβίδων.

- Αν η μπαταρία με την οποία θέλετε να χρησιμοποιήσετε αυτόν το φορτιστή είναι μόνιμα τοποθετημένη σε αυτοκίνητο, συμβουλευτείτε και το εγχειρίδιο χρήσης και/συντήρησης του αυτοκινήτου στο κεφάλαιο »ΗΛΕΚΤΡΙΚΗ ΕΓΚΑΤΑΣΤΑΣΗ» ή »ΣΥΝΤΗΡΗΣΗ». Κατά προτίμηση αποσυνδέστε, πριν εκτελέσετε τη φόρτιση, το θετικό καλώδιο που αποτελεί μέρος της ηλεκτρικής εγκατάστασης του αυτοκινήτου.

(RO)



ATENȚIE: ÎNAINTE DE FOLOSIREA REDRESORULUI CITIȚI CU ATENȚIE MANUALUL DE INSTRUCȚIUNI!

1. SIGURANȚA GENERALĂ PENTRU FOLOSIREA ACESTUI REDRESOR



- În timpul încărcării, bateriile emană gaze explozive, evitați formarea flăcărilor și a scânteiilor. NU FUMAȚI.
- În timpul încărcării, poziționați bateriile în spații aerisite.



- **Persoanele fără experiență trebuie să fie instruite corespunzător înainte de a folosi aparatul.**
- **Aparatul poate fi utilizat de copiii în vârstă de peste 8 ani și de persoane cu capacități fizice, senzoriale sau mentale reduse sau fără experiența sau cunoștințele necesare, cu condiția să fie sub supraveghere sau după ce au primit instrucțiuni privind folosirea sigură a aparatului și înțelegerea pericolelor inerente acestuia.**
- **Copiii nu trebuie să se joace cu aparatul.**
- **Curățarea și întreținerea care se efectuează de către utilizator nu trebuie efectuată de copiii nesupravegheați.**
- Debransați cablul de alimentare de la rețea înainte de conectarea sau deconectarea cablurilor de încărcare de la baterie.
- Nu conectați și nu deconectați cleștii la baterie cu redresorul în funcțiune.
- Nu folosiți sub niciun motiv redresorul în interiorul unui autovehicul sau sub capotă.
- Înlocuiți cablul de alimentare numai cu un cablu original.
- În cazul în care cablul de alimentare este deteriorat, acesta trebuie să fie înlocuit de fabricant sau de serviciul acestuia de asistență tehnică sau, oricum, de către o persoană cu o calificare similară, pentru a preveni orice risc.
- Nu folosiți redresorul pentru încărcarea bateriilor de tip neîncărcabil.
- Verificați că tensiunea de alimentare disponibilă corespunde celei indicate pe placa de identificare a redresorului.
- Pentru a nu deteriora partea electronică a vehiculelor, citiți, păstrați, respectați cu atenție recomandările furnizate de fabricanții acestor vehicule, când folosiți redresorul atât la încărcare cât și la pornire; același lucru este valabil pentru indicațiile furnizate de

fabricantul bateriilor.

- Acest redresor cuprinde anumite părți, cum ar fi întrerupătoarele sau releele, care pot provoca arcuri electrice sau scântei; prin urmare, dacă este folosit într-un garaj sau într-un spațiu asemănător, puneți redresorul într-o încăpere sau într-o cutie corespunzătoare acestui scop.

- Intervențiile de reparație sau întreținere în interiorul redresorului trebuie efectuate numai de către personal expert.



DEBRANȘAȚI ÎNTOTDEAUNA CABLUL DE ALIMENTARE DE LA REȚEA ÎNAINTE DE A EFECTUA ORICE INTERVENȚIE DE ÎNTREȚINERE A ÎNCĂRCĂTORULUI.

2. INTRODUCERE ȘI DESCRIERE GENERALĂ

- Acest încărcător permite încărcarea bateriilor pe bază de plumb cu electrolit liber, ermetice și cu litium, utilizate la vehiculele cu motor (benzină și diesel), motociclete, ambarcațiuni etc.

- Acumulatorii reîncărcabili în funcție de tensiunea de ieșire disponibilă: 6V, 12V și 24V (vezi plăcuță de identificare).

- Acest încărcător, în funcție de model, se poate alimenta la 230V 50/60Hz sau 110V 50/60Hz (vezi plăcuță de identificare) monofazic.

Curentul și tensiunea de încărcare furnizate de aparat sunt controlate electronic și urmează curba de încărcare IU sau U.

- Dotări de serie:

- Aparatul permite conectarea în ieșire a unor diferite tipologii de cabluri pentru reîncărcarea bateriilor:
 - cabluri prevăzute cu ochetei;
 - cabluri prevăzute cu clești.

3. INSTALAREA

AMPLASAREA REDRESORULUI

- În timpul funcționării, așezați redresorul în mod stabil.

- Evitați ridicarea redresorului cu ajutorul cablului de alimentare sau al cablului de încărcare.

CONECTAREA LA REȚEAUA DE ALIMENTARE

- Încărcătorul trebuie să fie conectat numai la un sistem de alimentare cu conductor de nul legat la pământ.

Controlați că tensiunea rețelei este echivalentă cu tensiunea de funcționare.

- Linia de alimentare va trebui dotată cu sisteme de protecție, precum siguranțe fuzibile sau întrerupătoare automate, suficiente pentru a suporta absorbția maximă a aparatului (vezi plăcuță de identificare).

- Conectarea la rețea trebuie efectuată prin cablul special prevăzut.

- Eventualele prelungitoare ale cablului de alimentare trebuie să aibă o secțiune adecvată și, în orice caz, nu inferioară celei a cablului furnizat.

4. FUNCȚIONAREA

PREGĂTIREA PENTRU ÎNCĂRCARE

NB: Înainte de a efectua încărcarea, verificați capacitatea bateriilor (Ah), care nu trebuie să fie mai mică de cea indicată pe placa indicatoare (C min).

Executați instrucțiunile urmând strict ordinea de mai jos.

- Scoateți capacele bateriei (dacă sunt prezente), astfel încât gazele produse în

timpul încărcării să poată ieși.

- Controlați ca nivelul electrolitului să acopere plăcile bateriilor; dacă acestea sunt descoperite adăugați apă distilată până la acoperirea lor cu 5 - 10 mm.



ATENȚIE! FIȚI FOARTE ATENȚI ÎN TIMPUL ACESTEI OPERAȚIUNI, DEOARECE ELECTROLITUL ESTE UN ACID DEOSEBIT DE COROZIV.

- Verificați că redresorul este deconectat de la rețea.

- Verificați polaritatea bornelor bateriei: pozitiv (simbolul +) și negativ (simbolul -).

NOTĂ: dacă simbolurile nu se disting, vă reamintim că borna pozitivă este aceea care nu este legată la caroseria mașinii.

- Cuplați cleștele marcat cu roșu la borna pozitivă a bateriei (simbolul +).

- Cuplați cleștele marcat cu negru la caroseria mașinii, departe de baterie și de conducta carburantului.

NOTĂ: dacă bateria nu este instalată pe mașină, cuplați direct la borna negativă a bateriei (simbolul -).

5. SFATURI UTILE

- Curățați borna pozitivă și cea negativă de încrustații posibile de oxid pentru a asigura un contact bun al cleștilor.

- Dacă bateria la care se dorește folosirea acestui redresor este instalată în permanență pe un vehicul, consultați și manualul de instrucțiuni și/sau de întreținere a vehiculului la rubrica "INSTALAȚIE ELECTRICĂ" sau "ÎNTREȚINERE". Înainte de a începe încărcarea, este bine să deconectați cablul pozitiv care face parte din instalația electrică a vehiculului.

(SV)



VIKTIGT: LÄS BRUKSANVISNINGEN NOGGRANT INNAN NI ANVÄNDER BATTERILADDAREN

1. ALLMÄNNA SÄKERHETSANVISNINGAR FÖR ANVÄNDNINGEN AV DENNA BATTERILADDARE



- Under laddningen avger batterierna explosiva gaser. Förhindra att lågor och gnistor bildas. RÖK EJ.

- Placera de batterier som ska laddas på en väl ventilerad plats.



- Vid brist av kunskap ska personer instrueras innan apparaten används.

- Apparaten får lov att användas av barn över 8 år och av personer med nedsatt fysisk, sensorisk eller mental förmåga, eller med bristande erfarenhet och kunskap förutsatt att de får tillsyn eller har fått instruktioner om hur apparaten ska användas på ett säkert sätt och förstår vilka risker det innebär.

- Barn får inte leka med apparaten.

- Rengöringen och underhållet som tillkommer användaren får inte utföras av

barn utan tillsyn.

- Batteri laddaren används endast för inomhusbruk (Restriktionen gäller endast för Finland).
- Drag alltid först ut stickkontakten ur eluttaget innan laddningskablarna ansluts till eller lossas från batteriet.
- Anslut eller fränkoppla inte batteriladdarens tänger till eller från batteriet när batteriladdaren är i funktion.
- Använd absolut inte batteriladdaren inuti ett fordon eller i motorutrymmet.
- Byt endast ut matningskabeln mot en originalkabel.
- Om elkabeln är skadad ska den bytas ut av tillverkaren eller av tillverkarens tekniska servicecenter, eller av en person som har likvärdig behörighet, för att förhindra eventuella risker.
- Använd inte batteriladdaren för att ladda ej laddningsbara batterier.
- Kontrollera att den tillgängliga matningsspänningen motsvarar den som indikeras på skylten på batteriladdaren.
- För att inte skada fordonens elektroniska system ska man läsa, spara och noggrant följa de anvisningar som tillhandahålls av fordonstillverkaren, både när man använder batteriladdaren för laddning och för start. Detsamma gäller för anvisningarna från batteritillverkaren.

- Denna batteriladdare innehåller delar som strömbrytare och reläer, som kan framkalla ljusbågar eller gnistor. Om laddaren används på en bilverkstad eller liknande bör den således placeras på en säker och för ändamålet lämplig plats.
- Reparations- eller underhållsgrepp inne i batteriladdaren får endast utföras av kunnig personal.



TA ALLTID BORT NÄTKABELN FRÅN ELUTTAGET INNAN NÅGON FORM AV UNDERHÅLLSÅTGÄRD INLEDS PÅ BATTERILADDAREN.

2. INLEDNING OCH ALLMÄN BESKRIVNING

- Denna batteriladdare tillåter att ladda blybatterier med fri elektrolyt, slutna batterier och litiumbatterier på motor drivna fordon (bensin och diesel), motorcyklar, båt o.s.v.
- Laddningsbara ackumulatörer baserat på tillgänglig utspänning: 6V, 12V och 24V (se märkskylten).
- Beroende på modell kan denna batteriladdare ha enfas strömförsörjning 230V 50/60Hz eller 110V 50/60Hz (se märkskylten).
Laddningsströmmen och laddningsspänningen som avges av apparaten styrs elektroniskt och följer en laddningskurva IU eller U.
- Utrustning som medföljer som standard:
 - Apparaten tillåter utgångsanslutning av olika typer av kablar för att ladda batterierna:
 - Kablar försedda med öglor.
 - Kablar försedda med klämmor.

3. INSTALLATION

BATTERILADDARENS PLACERING

- Under användning ska batteriladdaren stå stabilt.
- Undvik att lyfta batteriladdaren genom att ta tag i matningskabeln eller laddningskabeln.

ANSLUTNING TILL ELNÄTET

- Batteriladdaren får endast anslutas till ett kraftsystem med neutralledare ansluten till jord.
Kontrollera att nätspänningen överensstämmer med driftspänningen.
- Matningslinjen ska vara försedd med skyddssystem, såsom säkringar eller automatsäkringar, som är tillräckliga för att tåla apparatens maximala strömförbrukning (se märkskylten).
- Anslutning till elnätet ska utföras med den avsedda nätkabeln.
- Eventuella förlängningskablar till nätkabeln ska ha lämpligt tvärsnitt, vilket inte får vara mindre än det på den medföljande kabeln.

4. FUNKTION

FÖRBEREDELSE INFÖR LADDNINGEN

Obs! Innan laddningen påbörjas, kontrollera att kapaciteten på batterierna som ska laddas (Ah) inte är lägre än den som anges på märkskylten (C min).

Utför instruktionerna genom att noga följa ordningen nedan.

- Ta bort batterikåporna (i förekommande fall) så att gasen som genereras under laddningen kan komma ut.
- Kontrollera att elektrolytvätskenivån täcker batteriplattorna. Om de inte är täckta ska du tillsätta destillerat vatten tills de är täckta med 5-10 mm.



OBSERVERA! VAR MYCKET OPPMÄRKSAM NÄR DENNA ÅTGÄRD UTFÖRS EFTERSOM ELEKTROLYTVÄTSKAN ÄR EN MYCKET FRÄTANDE SYRA.

- Kontrollera att batteriladdaren är bortkopplad från elnätet.
- Kontrollera polariteten vid batteriklämmorna: plus (symbolen +) och minus (symbolen -).
OBS! Om symbolerna inte kan läsas, kom ihåg att plusklämman är den som inte är ansluten till fordonets chassi.
- Anslut den röda laddningsklämman till batteriets pluspol (symbol +).
- Anslut den svarta laddningsklämman till fordonschassit, på avstånd från batteriet och bränsleledningen.
OBS! Om batteriet inte är installerat på fordonet, utför direktanslutning till batteriets minusklämma (symbol -).

5. RÅD

- Rengör den positiva och den negativa klämman från eventuella oxidavlagringar så att god kontakt erhålles.
- Om batteriladdaren ska användas till ett fast monterat batteri i ett fordon bör även fordonets instruktionsbok konsulteras, se kapitlet "ELEKTRISKT SYSTEM" eller "UNDERHÅLL". Innan laddningen påbörjas är det lämpligt att koppla från den positiva batterikabeln som tillhör fordonets elektriska system från batteriet.

(CS)



UPOZORNĚNÍ: PŘED POUŽITÍM NABÍJEČKY AKUMULÁTORŮ SI POZORNĚ PŘEČTĚTE NÁVOD K POUŽITÍ!

1. ZÁKLADNÍ BEZPEČNOSTNÍ POKYNY PRO POUŽITÍ TĚTO NABÍJEČKY AKUMULÁTORŮ



- Během nabíjení se z akumulátorů uvolňují výbušné plyny, a proto zabraňte vzniku plamenů a jisker. NEKURŤTE.
- Umístěte nabíjené akumulátory do větraného prostoru.



- **Osoby, které nemají zkušenosti se zařízením, by měly být před jeho používáním vhodně vyškoleny.**
- **Zařízení může být používáno dětmi ve věku nejméně 8 let a osobami se sníženými fyzickými, sensorickými nebo mentálními schopnostmi, nebo osobami bez zkušeností či potřebných znalostí, za předpokladu, že jsou pod dozorem, nebo že jim byly poskytnuty pokyny ohledně bezpečného použití zařízení a ohledně pochopení souvisejících nebezpečí.**
- **Děti se nesmí hrát se zařízením.**
- **Čištění a údržba zařízení, kterou má provést uživatel, nesmí být prováděna dětmi a bez dozoru.**
- Před zapojením nebo odpojením nabíjecích kabelů od akumulátoru odpojte nejdříve napájecí kabel ze sítě.
- Nepřipojujte ani neodpojujte kleště k/od akumulátoru během činnosti nabíječky akumulátorů.
- V žádném případě nepoužívejte nabíječku akumulátorů uvnitř vozidla nebo v prostoru motoru.
- Napájecí kabel nahraďte pouze originálním kabelem.
- Když je napájecí kabel poškozen, musí být vyměněn výrobcem, jeho servisní službou nebo osobou s podobnou kvalifikací a s cílem zabránit jakémukoliv riziku.
- Nepoužívejte nabíječku akumulátorů pro nabíjení akumulátorů, které nelze nabíjet.
- Zkontrolujte, zda napájecí napětí, které je k dispozici, odpovídá napětí uvedenému na identifikačním štítku nabíječky akumulátorů.
- Abyste při použití nabíječky akumulátorů k nabíjení i ke startování nepoškodili elektroniku vozidel, pozorně si přečtěte, uschovejte a dodržujte upozornění dodaná výrobcem samotných vozidel; to samé platí i pro pokyny dodané výrobcem akumulátorů.
- Součástí této nabíječky akumulátorů jsou komponenty, jako např. vypínače nebo relé, které mohou vyvolat vznik oblouku nebo jiskry; proto při použití nabíječky akumulátorů v autodiagnostice nebo v podobném prostředí uložte nabíječku do místnosti nebo do obalu vhodného k tomuto účelu.
- Zásahy do vnitřních částí nabíječky akumulátorů v rámci oprav nebo údržby může provádět pouze zkušený personál.



PŘED VYKONÁNÍM JAKÉHOKOLI ZÁKROKU ÚDRŽBY NABÍJEČKY AKUMULÁTORŮ ODPOJTE NAPÁJECÍ KABEL ZE SÍTĚ.

2. ÚVOD A ZÁKLADNÍ POPIS

- Tato nabíječka akumulátorů umožňuje nabíjení olověných akumulátorů s volným elektrolytem, hermeticky uzavřených a lithiových akumulátorů, používaných v motorových vozidlech (benzinových i naftových), motocyklech, plavidlech atd.
- Akumulátory, které lze nabíjet v závislosti na dostupném výstupním napětí: 6V, 12V + 24V (v závislosti na údajích na jmenovitém štítku).
- Tato nabíječka akumulátoru může být, v závislosti na modelu, uzpůsobena pro jednofázové napájení 230 V~ - 50/60 Hz nebo 110 V~ - 50/60 Hz (v závislosti na údajích na jmenovitém štítku).
- Nabíjecí proud a napětí, které zařízení dodává, jsou řízeny elektronikou a sledují nabíjecí křivku IU nebo U.
- Standardní výbava:
 - Zařízení umožňuje připojit na výstup různé druhy kabelů pro nabíjení akumulátorů:
 - kabely vybavené očky;
 - kabely vybavené kleštěmi.

3. INSTALACE UMÍSTĚNÍ NABÍJEČKY AKUMULÁTORŮ

- Během činnosti musí být nabíječka umístěna stabilním způsobem.
- Zabraňte zvedání nabíječky akumulátorů prostřednictvím napájecího kabelu nebo nabíjecího kabelu.

PŘIPOJENÍ K ELEKTRICKÉ SÍTĚ

- Nabíječka akumulátorů musí být připojena výhradně k napájecímu systému s uzemněným nulovým vodičem.
- Zkontrolujte, zda napětí sítě odpovídá provoznímu napětí.
- Napájecí vedení bude muset být vybaveno ochrannými systémy, jako např. pojistkami nebo automatickými vypínači, schopnými snášet maximální proudovou zátěž zařízení (v závislosti na údajích na jmenovitém štítku).
- Připojení do sítě musí být provedeno použitím příslušného kabelu.
- Případně prodlužovací kabely napájecího kabelu musí mít vhodný průřez, který nesmí být v žádném případě menší než průřez dodaného kabelu.

4. ČINNOST

PŘÍPRAVA K NABÍJENÍ

POZN.: Než přistoupíte k nabíjení, přesvědčte se, zda kapacita akumulátorů (Ah), které hodláte nabíjet, není nižší než kapacita uvedená na identifikačním štítku (C min).

Provedte jednotlivé úkony dle pokynů a přísně dodržujte níže uvedený postup.

- Odmontujte kryty akumulátoru (jsou-li součástí), aby se mohly uvolnit plyny vznikající při nabíjení.
- Zkontrolujte, zda hladina elektrolytu zakrývá desky akumulátorů; v případě, že jsou desky odhalené, dolijte destilovanou vodu tak, aby zůstaly ponořené 5-10 mm.



UPOZORNĚNÍ! VĚNUJTE TOMUTO ÚKONU MAXIMÁLNÍ POZORNOST, PROTOŽE ELEKTROLYT JE TVOŘEN VYSOCE KOROZIVNÍ KYSELINOU.

- Zkontrolujte, zda je nabíječka akumulátorů

odpojena od sítě.

- Zkontrolujte polaritu svorek akumulátoru: kladný pól se symbolem + a záporný pól se symbolem -.
- POZNÁMKA: Když nelze rozeznat symboly, pamatujte, že kladný pól je ten, který není připojen k podvozku auta.
- Připojte nabíjecí kleště červené barvy ke kladnému pólu akumulátoru (symbol +).
- Připojte nabíjecí kleště černé barvy k podvozku auta, v dostatečné vzdálenosti od akumulátoru a od palivového rozvodu.
- POZNÁMKA: Když akumulátor není nainstalován v autě, proveďte připojení přímo k záporné svorce akumulátoru (symbol -).

5. PRAKTICKÉ RADY

- Vyčistěte zápornou a kladnou svorku od možných nánosů oxidu, abyste zajistili dobrý kontakt kleští.
- Když je akumulátor, který se má nabíjet nabíječkou akumulátorů, pevně vložen do vozidla, seznamte se také s návodem k použití a/nebo údržbě vozidla, konkrétně s částí „ELEKTROINSTALACE“ nebo „ÚDRŽBA“. Před zahájením nabíjení je vhodné odpojit kladný kabel, který tvoří součást elektroinstalace vozidla.

(HR-SR)



POZOR: PRIJE UPOTREBE PUNJAČA BATERIJE PAŽLJIVO PROČITATI PRIRUČNIK ZA UPOTREBU!

1. OPĆA SIGURNOST ZA UPOTREBU OVOG PUNJAČA BATERIJE



- Tijekom punjenja baterije stvaraju se eksplozivni plinovi, izbjegavajte stvaranje plamena i iskri. NE SMIJE SE PUŠITI.
- Postaviti bateriju koja se puni na dobro prozračeno mjesto.



- Neiskusne osobe moraju dobiti prikladnu obuku prije upotrebe uređaja.
- Aparat mogu koristiti djeca od 8 i više godina starosti kao i osobe sa smanjenim fizičkim, osjetnim i psihičkim sposobnostima ukoliko su pod nadzorom ili pak nakon što su obučene za sigurno korištenje aparata i ukoliko su shvatile opasnosti koje mogu nastati prilikom uporabe istog.
- Djeca se ne smiju igrati aparatom.
- Čišćenje i održavanje koje treba izvršiti korisnik ne smiju vršiti djeca bez nadzora odraslih.
- Izvući kabel za napajanje iz struje prije priključivanja ili isključivanja kabela za punjenje baterije.
- Hvataljke se ne smiju priključiti ni isključiti na bateriju dok je punjač baterije uključen.
- U nijednom slučaju se ne smije upotrebljavati punjač baterije unutar vozila ili ispod haube.
- Zamijeniti kabel za napajanje samo originalnim kabelom.

- Ako je kabel za napajanje oštećen, isti mora zamijeniti proizvođač ili njegov servis za tehničku asistenciju odnosno osoba koja ima sličnu kvalifikaciju kako ne bi nastali rizici.
 - Punjač baterije se ne smije upotrebljavati za punjenje baterija koje se ne mogu puniti.
 - Provjeriti da napon napajanja na raspolaganju odgovara naponu navedenom na pločici sa podacima punjača baterije.
 - Kako se ne bi oštetila elektronika vozila, potrebno je pročitati, sačuvati i pažljivo pridržavati se upozorenja koja navode proizvođači vozila, kada se upotrebljava punjač baterije tijekom punjenja i tijekom paljenja; isto vrijedi za upozorenja koja navodi proizvođač baterije.
 - Ovaj punjač baterije se sastoji od dijelova, kao na primjer sklopki i releja, koji mogu proizvesti lukove ili iskre; stoga ako se upotrebljava u garaži ili sličnom prostoru, položiti punjač baterije u prostoriju ili u prikladnu futrolu.
 - Popravke ili servisiranje unutar punjača baterije mora vršiti iskusna osoba.
- UVIJEK ISKOPČAJTE KABEL ZA NAPAJSANJE IZ MREŽE PRIJE VRŠENJA BILO KOJEG ZAHVATA ODRŽAVANJA NA PUNJAČU AKUMULATORA.**

2. UVOD I OPĆI OPIS

- Ovaj punjač akumulatora omogućava punjenje olovnih akumulatora sa slobodnim elektrolitima, kao i hermetičnih i litijskih akumulatora koji se koriste u motornim (benzinskim i dizelskim) vozilima, motociklima, brodovima itd.
- Akumulatori koji se mogu puniti ovisno o dostupnom izlaznom naponu: 6V, 12V i 24V (prema podacima na pločici).
- Ovaj punjač akumulatora, ovisno o modelu, može imati jednofazno napajanje od 230V 50/60Hz ili 110V 50/60Hz (prema podacima na pločici).
- Struja i napon punjenja koje daje aparat elektronički se kontroliraju i slijede krivu punjenja IU ili U.
- Isporučena oprema:
 - Aparat omogućava spajanje na izlazu raznih tipologija kabela za punjenje akumulatora:
 - kabeli s ušicama;
 - kabeli sa klijestima.

3. INSTALIRANJE POSTAVLJANJE PUNJAČA AKUMULATORA

- Za vrijeme rada stabilno postavite punjač akumulatora.
- Izbjegavajte dizati punjač akumulatora pomoću kabela za napajanje ili pomoću kabela za punjenje.

SPAJANJE NA MREŽU

- Punjač akumulatora mora biti spojen isključivo na sustav napajanja sa neutralnim uzemljenim vodičom.
- Provjerite poklapa li se napon mreže s radnim naponom.
- Sustav napajanja mora biti opremljen zaštitnim sustavima, kao što su osigurači ili automatske sklopke, koji moraju biti dovoljno jaki da izdrže maksimalnu potrošnju uređaja (prema podacima na pločici).
- Spajanje na mrežu mora biti izvršeno prikladnim kabelom.
- Eventualni produžni kabeli za napajanje moraju imati prikladni promjer, koji ni u

kom slučaju ne smije biti manji od promjera isporučenog kabela.

(PL)

4. RAD

PRIPREMA ZA PUNJENJE

Napomena: Prije početka punjenja, provjerite da kapacitet akumulatora (Ah) koje namjeravate napuniti nije niži od kapaciteta navedenog na pločici uređaja (C min).

Slijedite upute pažljivo prema niže navedenom redoslijedu.

- Skinite poklopce s akumulatora (ako su prisutni) kako bi plinovi koji se stvaraju prilikom punjenja mogli izaći.
- Provjerite pokriva li razina elektrolita ploče akumulatora; ako ploče nisu prekrivene, dodajte destiliranu vodu sve dok ne pokrijete ploče za 5-10 mm.



PAŽNJA! TIJEKOM OVE RADNJE POTREBAN JE MAKSIMALNI OPREZ JER JE ELEKTROLIT VRLO KOROZIVNA KISELINA.

- Provjerite je li punjač akumulatora iskopčan s mreže.
- Provjerite pol stezaljki akumulatora: pozitivan (simbol +) i negativan (simbol -).
NAPOMENA: ako nije moguće raspoznati simbole, podsjećamo da je pozitivna stezaljka ona koja nije spojena na šasiju vozila.
- Spojite kliješta za punjenje crvene boje na pozitivnu stezaljku akumulatora (simbol +).
- Spojite kliješta za punjenje crne boje na šasiju vozila, daleko od akumulatora i od cijevi za gorivo.
NAPOMENA: ako akumulator nije postavljen u vozilo, spojiti se izravno na negativnu stezaljku akumulatora (simbol -).

5. KORISNI SAVJETI

- Očistiti pozitivni i negativni pritezač od mogućih oksidacija kako bi se osigurao dobar dodir hvataljki.
- Ako je baterija za koju se namjerava upotrijebiti punjač baterije stalno postavljena na vozilo, potrebno je konzultirati priručnik za upotrebu i/ili servisiranje vozila, poglavlje "ELEKTRIČNI SUSTAV" ili "SERVISIRANJE". Po mogućnosti prije punjenja isključiti pozitivni kabel koji čini sastavni dio električnog sustava vozila.



UWAGA: PRZED UŻYCIEM PROSTOWNIKA DO ŁADOWANIA AKUMULATORÓW NALEŻY UWAŻNIE PRZECZYTAĆ INSTRUKCJĘ OBSŁUGI!

1. OGÓLNE BEZPIECZEŃSTWO PODCZAS OBSŁUGI PROSTOWNIKA



- Akumulatory wydzielają podczas ładowania gazy wybuchowe, należy unikać powstawania płomieni i iskier. NIE PALIĆ
- Umieścić akumulatory przeznaczone do ładowania w miejscu wietrzonym.



- **Przed użyciem urządzenia osoby niedoświadczone muszą zostać odpowiednio przeszkolone.**
- **Urządzenie może być używane przez dzieci w wieku powyżej 8 lat oraz przez osoby o ograniczonych możliwościach fizycznych, czuciowych lub umysłowych nieposiadające doświadczenia lub wymaganej wiedzy, pod warunkiem, że będą z niego korzystały pod nadzorem lub po uzyskaniu wskazówek dotyczących bezpiecznego użytkowania urządzenia i zrozumienia zagrożeń z nim związanych.**
- **Nie pozwalają dzieciom bawić się urządzeniem.**
- **Czyszczenie i konserwacja, której wykonanie należy do obowiązków użytkownika nie może być wykonywane przez dzieci bez nadzoru.**
- Przed podłączeniem lub rozłączeniem kabli do ładowania akumulatora należy wyłączyć kabel zasilania z sieci.
- Nie podłączać zacisków do akumulatora lub rozłączać ich podczas funkcjonowania prostownika.
- Nie używać w żadnym przypadku prostownika wewnątrz pojazdu samochodowego lub pod pokrywą silnika.
- Wymienić kabel zasilania wyłącznie na kabel oryginalny.
- Jeżeli przewód zasilania jest uszkodzony, musi zostać wymieniony przez producenta lub przez autoryzowany przez niego serwis techniczny lub w każdym razie przez osobę posiadającą podobne kwalifikacje, w sposób zapobiegający wszelkim zagrożeniom.
- Nie używać prostowników do ładowania akumulatorów, które nie nadają się do ładowania.
- Sprawdzić, czy napięcie zasilania znajdujące się do dyspozycji, odpowiada napięciu podanemu na tabliczce danych prostownika.
- Aby nie uszkodzić instalacji elektronicznej pojazdów należy przeczytać, zachować i skrupulatnie przestrzegać zalecenia podane przez producentów pojazdów w przypadku, kiedy prostowniki są używane zarówno do ładowania jak i do uruchamiania tychże pojazdów; to samo dotyczy wskazówek podanych przez producenta akumulatorów.
- Niniejszy prostownik zawiera elementy, takie jak wyłączniki lub przełączniki, które

mogą powodować powstawanie łuków lub iskier; dlatego też, jeżeli będzie używany w warsztatach samochodowych lub w podobnym otoczeniu należy umieścić go w odpowiednim lokalu lub pokrowcu przeznaczonym do tego celu.

- Operacje naprawy lub konserwacji wewnątrz prostownika powinny być wykonywane wyłącznie przez personel doświadczony.



ODŁĄCZYĆ ZAWSZE PRZEWÓD ZASILAJĄCY OD SIECI PRZED WYKONANIEM JAKIEJKOLWIEK CZYNNOŚCI KONSERWACYJNEJ NA PROSTOWNIKU.

2. WPROWADZENIE I OGÓLNY OPIS

- Opisujący prostownik umożliwia ładowanie akumulatorów ołowiowych o swobodnym przepływie elektrolitu, hermetycznych i litowych używanych w pojazdach silnikowych (benzyna i diesel), motocyklach, łodziach, itp.
- Akumulatory z możliwością doładowania w zależności od napięcia wyjściowego do dyspozycji: 6V, 12V i 24V (zgodnie z tabliczką danych).

- Opisujący prostownik - w zależności od modelu - może być dostępny z zasilaniem jednofazowym o mocy 230V 50/60Hz lub 110V 50/60Hz (zgodnie z tabliczką danych).

Prąd i napięcie ładowania dostarczane przez urządzenie są sterowane elektronicznie i przestrzegają krzywej ładowania IU lub U.

- Wyposażenie w zestawie:

- Urządzenie umożliwia podłączenie na wyjściu różnych rodzajów przewodów umożliwiających doładowanie akumulatorów:
 - przewody wyposażone w uchwyty oczkowe;
 - przewody wyposażone w zaciski.

3. INSTALOWANIE

USTAWIENIE PROSTOWNIKA

- Podczas funkcjonowania należy ustawić prostownik w stabilny sposób.
- Nie podnosić prostownika wykorzystując w tym celu przewód zasilania lub przewód do ładowania.

PODŁĄCZENIE DO SIECI

- Prostownik należy podłączyć wyłącznie do sieci zasilania, w której znajduje się uziemiony przewód neutralny.

Sprawdzić czy napięcie sieciowe odpowiada wartości napięcia funkcjonowania.

- Sieć zasilająca musi być wyposażona w odpowiednie systemy zabezpieczające, takie, jak bezpieczniki lub wyłączniki automatyczne, dostosowane do maksymalnej mocy pobieranej przez urządzenie (zgodnie z tabliczką danych).

- Podłączyć do sieci wykorzystując odpowiedni przewód.

- Ewentualne przedłużenia przewodu zasilania powinny posiadać odpowiedni przekrój, który nie może być nigdy mniejszy od przekroju dostarczonego przewodu.

4. FUNKCJONOWANIE

PRZYGOTOWANIE DO ŁADOWANIA

Zauważ: Przed przystąpieniem do ładowania należy sprawdzić czy pojemność akumulatorów (Ah), które zamierza się ładować, nie jest mniejsza od pojemności podanej na tabliczce (C min).

Postępować zgodnie z instrukcją, skrupulatnie przestrzegać podanej niżej kolejności.

- Zdjąć pokrywy akumulatora (jeżeli występują), w ten sposób gazy powstające podczas ładowania mogą się ulatniać.

- Sprawdzić czy poziom elektrolitu zakrywa płytki akumulatorów; jeżeli tak nie jest należy dolać wody destylowanej, aż do ich zalania na 5-10 mm.



UWAGA! ZACHOWAĆ SZCZEGÓLNA OSTROŻNOŚĆ PODCZAS TEJ CZYNNOŚCI, PONIEWAŻ ELEKTROLIT JEST KWASEM WYSOCE KOROZYJNYM.

- Sprawdzić czy prostownik jest odłączony od gniazda sieciowego.

- Sprawdzić polaryzację zacisków akumulatora: dodatnia (symbol +) i ujemna (symbol -).

ZAUWAŻ: jeżeli symbole nie są dobrze widoczne przypomina się, że zacisk dodatni jest zaciskiem, który nie jest podłączony do podwozia pojazdu.

- Podłączyć zacisk kleszczowy przewodu ładującego koloru czerwonego do zacisku dodatniego akumulatora (symbol +).

- Podłączyć zacisk przewodu ładującego koloru czarnego do podwozia pojazdu, w odpowiedniej odległości od akumulatora oraz od przewodu paliwa.

Uwaga: jeżeli akumulator nie został zamontowany w pojeździe, należy podłączyć się bezpośrednio do zacisku ujemnego akumulatora (symbol -).

5. UŻYTECZNE WSKAZÓWKI

- Wyczyścić zacisk dodatni i ujemny z osadów tlenku, aby zapewnić w ten sposób dobry styk zacisków.

- Jeżeli akumulator, z którym zamierza się wykorzystać ten prostownik jest na stałe zamontowany w pojeździe, należy przeczytać również instrukcje obsługi i/lub konserwacji pojazdu, pod hasłem "INSTALACJA ELEKTRYCZNA" lub "KONSERWACJA". Przed przystąpieniem do ładowania najlepiej jest rozłączyć kabel dodatni, będący częścią instalacji elektrycznej pojazdu.

(FI)



HUOMIO: LUE TÄMÄ KÄYTTÖOHJE HUOLELLISESTI ENNEN AKKULATURIN KÄYTTÄMISTÄ!

1. TÄMÄN AKKULATURIN KÄYTTÖÄ KOSKEVAT YLEISET TURVALLISUUSOHJEET



- Latauksen aikana syntyy räjähtäviä kaasuja. Eliminoi liekin ja kipinämuodostusriski. ÄLÄ POLTA!

- Aseta ladattavat akut tuuletettuun tilaan.



- Ammattitaidottomat henkilöt on koulutettava asianmukaisesti ennen laitteen käyttöä.

- Laitteen käyttö on sallittu vähintään 8-vuotiaille lapsille ja sellaisille henkilöille, joiden fyysinen, aisteihin liittyvä tai

henkinen toimintakyky on rajoittunut tai joilla ei ole kokemusta tai tietoa laitteen käytöstä sillä ehdolla, että heitä valvotaan ja opastetaan laitteen turvalliseen käyttöön liittyen ja että he tuntevat sen käyttöön liittyvät vaarat.

- **Lapset eivät saa leikkiä laitteella.**
- **Lapset eivät saa suorittaa säännöllistä puhdistusta ja huoltoa ilman valvontaa.**
- Akkulaturi sopii ainoastaan sisäkäyttöön (rajoitus koskee vain Suomea).
- Vedä aina pistotulppa pois sähköasiasta ennen kuin liität latauskaapeli akkuun tai poistat ne siitä.
- Älä kytke tai irrota pihtejä akkulaturin käydessä.
- Älä koskaan käytä akkulaturia ajoneuvon sisällä tai moottoritallassa.
- Vaihtakaa syöttökaapeli vain alkuperäiseen malliin.
- Anna vahingoittuneen virtajohdon vaihto valmistajan, valtuutetun teknisen huoltopalvelun tai vastaavan ammattipätevyuden omaavan henkilön suoritettavaksi, jotta vältyt mahdollisilta onnettomuuksilta.
- Älä käytä akkulaturia kertakäyttöisten akkujen lataamiseen.
- Tarkista, että käytettävän verkon jännite vastaa akkulaturissa olevan kyltin tietoja.
- Ajoneuvojen elektroniikan vaurioittamisen välttämiseksi lue, säilytä ja noudata tarkasti ajoneuvojen valmistajien antamia varoituksia, kun akkulaturia käytetään lataukseen ja käynnistämiseen; sama koskee akkulaturin valmistajan antamia ohjeita.
- Tämä akkulaturi sisältää osia, kuten virtakytkin ja rele, jotka voivat aiheuttaa valokaaria ja kipinöitä. Kun laturia käytetään autokorjaamolla tai vastaavassa paikassa, se pitää näin ollen sijoittaa turvalliseen ja käyttötarkoitukseen sopivaan paikkaan.
- Vain pätevä asentaja saa suorittaa akkulaturin korjaus- ja huoltotoimenpiteet.

 **IRROTA VIRTAJOHTO AINA VERKOSTA ENNEN AKKULATURISSA SUORITETTAVIA TOIMENPITEITÄ.**

2. JOHDANTO JA YLEISKUVAUS

- Tällä akkulaturilla voidaan ladata lyijyakkuja vapaalla elektrolyytillä, hermeettisiä jalkuja sekä litiumakkuja, joita käytetään moottoriajoneuvoissa (bensa ja diesel), moottoripyörissä, veneissä jne.
- Ladattavat akut saatavilla olevan ulostulojännitteen mukaan ovat: 6V, 12V ja 24V (tietokyltin perusteella).
- Tämä akkulaturi voi mallin mukaan olla 230V 50/60Hz tai 110V 50/60Hz (tietokyltin perusteella) yksivaiheinen. Laitteen tuottamaa latausvirtaa ja -jännitettä valvotaan elektronisesti ja ne noudattavat latauskäyrää IU tai U.
- Sarjavarusteet:
 - Laitteen ulostuloon voidaan liittää erilaisia akkujen latausjohtoja:
 - silmukoilla varustetut johdot;
 - pihideillä varustetut johdot.

3. ASENNUS

AKKULATURIN SIJOTUS

- Aseta akkulaturi toiminnan aikana vakaalla tavalla.
- Vältä akkulaturin nostamista sähköjohdosta.

tai latausjohdosta.

VERKKOON KYTKENTÄ

- Akkulaturi voidaan kytkeä ainoastaan virransyöttöjärjestelmään maadoitetulla nollajohdimeillä.
- Tarkasta, että verkon jännite vastaa toimintajännitettä.
- Virransyöttölinja on oltava varustettu suojalaitteilla, kuten sulakkeet tai automaattikatkaisimet, jotka ovat riittävän suuria sietämään laitteen maksimiabsorptiota (tietokyltin perusteella).
- Verkkoliitäntä tehdään siihen tarkoitettulla johdolla.
- Mahdollisten sähköjohdon jatkeiden leikkauksen on oltava sopiva eikä koskaan pienempi kuin toimitetun johdon leikkaus.

4. TOIMINTA

VALMISTELU LATAUSTA VARTEN

HUOMIO: Tarkasta ennen latausta, että ladattavaksi aiotun akun kapasiteetti (Ah) ei ole alle kyltissä ilmoitetun kapasiteetin (C/min).

Noudata ohjeita tarkasti alla olevassa järjestyksessä.

- Poista akun kannet (jos mukana) niin, että latauksen aikana syntyvät kaasut pääsevät pois.
- Tarkasta, että elektrolyytin taso peittää akkujen levyt; jos ne ovat paljaat, lisää tislattua vettä, kunnes ne uppoavat 5 -10 mm.

 **VAROITUS! OLE MAHDOLLISIMMAN VAROVAINEN TÄMÄN TOIMENPITEEN AIKANA, KOSKA ELEKTROLYYTTI ON ERITTÄIN SYÖVYTTÄVÄ HAPPO.**

- Tarkasta, että akkulaturi on irti kytketty verkosta.
- Tarkasta akun liittimien napaisuus: positiivinen (symboli +) ja negatiivinen (symboli -).
- HUOMAA:** jos symbolit eivät erotu, muista, että positiivinen liitin on se, jota ei ole kytketty auton runkoon.
- Liitä punainen latauspihti akun positiiviseen liittimeen (symboli +).
- Liitä musta latauspihti auton runkoon, kauas akusta ja polttoainekanavasta.
- HUOMAA:** jos akkua ei ole asennettu autoon, liitä suoraan akun negatiiviseen liittimeen (symboli -).

5. YLEISIÄ NEUVOJA

- Puhdista navat mahdollisista happikasaumista niin, että kontakti on hyvä.
- Jos akkulaturilla ladataan ajoneuvoon pysyvästi asennettua akkua, sinun on luettava myös ajoneuvon käyttö- ja/tai huoltokirja kohdasta SÄHKÖVARUSTEET tai HUOLTO. Ennen kuin aloitat latauksen, irrota (mieluummin) ajoneuvon sähkölaitteiston positiivinenkaapeli.

(DA)



**GIV AGT: LÆS BRUGERVEJLEDNINGEN
OMHYGGELIGT IGENNEM, FØR
BATTERILADEN TAGES I BRUG.**

1. ALMENE SIKKERHEDSREGLER FOR ANVENDELSE AF DENNE BATTERILADER



- Under opladningen dannes der eksplosive gasser. Eliminér risici for flamme og gnistdannelse. RYG IKKE!
- Placér batterierne på et sted med god udluftning, mens de oplades.



- Uerfarne personer skal oplæres på passende vis, før de tager apparatet i brug.
- Apparatet kan anvendes af børn på mindst 8 år og personer med nedsatte fysiske, sansmæssige eller åndelige evner samt af personer, der ikke råder over den fornødne erfaring eller viden, såfremt de holdes under opsyn eller er blevet sat ind i, hvordan apparatet anvendes på sikker vis og har forstået de dermed forbundne farer.
- Børn må ikke lege med apparatet.
- Rengørings- og vedligeholdelsesopgaver, der påhviler brugeren, må ikke foretages af børn uden opsyn.

- Træk altid først stikket ud af stikkontakten, før ladekablerne sluttes til eller tages af batteriet.
- Batteriladen må ikke være i funktion, mens tængerne sluttes til eller tages af batteriet.
- Anvend aldrig batteriladeren inde i et køretøj eller i motorhjelmen.
- Forsyningsledningen må udelukkende udskiftes med et originalt.
- Hvis forsyningsledningen er beskadiget, skal den udskiftes af producenten eller af den tekniske assistance eller under alle omstændigheder af en person med tilsvarende kompetence for at undgå hvilken som helst risiko.
- Batteriladeren må ikke anvendes til opladning af batterier, der ikke kan genoplades.
- Kontrollér om netspændingen, som er til rådighed, stemmer overens med angivelserne på batteriladerens typeskilt.
- For at undgå at beskadige køretøjernes elektronik under opladning og igangsætning med batteriladeren, skal man læse, opbevare og nøje overholde anvisningerne fra det pågældende køretøjs fabrikant samt batteriproducentens anvisninger.
- Denne batterilader indeholder dele såsom strømafbrydere og relæer, som kan fremkalde lysbuer og gnister. Hvis batteriladeren anvendes på et bilværksted eller lignende, bør den således placeres på et sikkert sted eller opbevares i egnet indpakning.
- Reparations- og vedligeholdelsesarbejde på batteriladeren må kun udføres af erfarne fagmænd.



**STRØMKABLET SKAL ALTID
AFBRYDES FRA
NETFORSYNINGEN, FØR DER
FORETAGES HVILKEN SOM HELST FORM
FOR VEDLIGEHOLDELSE PÅ**

BATTERILADEREN.

2. INDLEDNING OG ALMENE BESKRIVELSE

- Denne batterilader gør det muligt at oplade blybatterier med fri elektrolyt, hermetisk forseglede batterier og litiumbatterier, der anvendes i motorkøretøjer (benzin og diesel), motorcykler, cykler, både osv.
- Opladelige batterier afhængigt af den tilgængelige udgangsspænding: 6V, 12V og 24V (ifølge datamærkatens).
- Denne batterilader kan afhængigt af modellen fungere med enfaset 230V 50/60Hz- eller 110V 50/60Hz-forsyning (ifølge datamærkatens).
- Ladestrømmen og -spændingen, som apparatet leverer, styres elektronisk og følger ladekurven IU eller U.
- Serieudstyr:
 - Apparatet gør det muligt at forbinde forskellige slags kabler til opladning af batterier ved udgangen:
 - kabler forsynet med løkker;
 - kabler forsynet med tang.

3. INSTALLATION

PLACERING AF BATTERILADEREN

- Under drift skal batteriladeren stå støt.
- Undlad at hive batteriladeren op med forsynings- eller opladningsledningen.

FORBINDELSE TIL NETFORSYNINGEN

- Batteriladeren må udelukkende forbindes til et forsyningsystem med en jordforbundet nulledning.
- Kontrollér, om netspændingen stemmer overens med driftsspændingen.
- Forsyningslinjen skal være forsynet med beskyttelsessystemer, såsom sikringer eller automatiske afbrydere, der kan holde til apparatets maksimale forbrug (ifølge datamærkatens).
- Forbindelsen til forsyningsnettet skal oprettes ved hjælp af det dertil beregnede kabel.
- Eventuelle forlængerledninger skal have et passende tværsnit, under ingen omstændigheder mindre end det medleverede kabels.

4. DRIFT

FORBEREDELSE TIL OPLADNINGEN

OBS: Før man går i gang med opladningen, skal man kontrollere, om kapaciteten for de batterier (Ah), der skal oplades, ikke er mindre end den, der er angivet på typeskiltet (C min).

Anvisningerne skal følges helt nøjagtigt i den rækkefølge, de er opført i nedenfor.

- Fjern batteridækslerne (såfremt de forefindes), så gassen, der opstår under opladningen, kan strømme ud.
- Kontrollér, at elektrolyttens niveau dækker batteripladerne; hvis de ikke er tildækket, hældes der destilleret vand på, indtil pladerne er 5-10 mm under vandet.



**GIV AGT! UDVIS STØRST MULIG
FORSIGTIGHED UNDER DETTE
ARBEJDE, DA ELEKTROLYTTEN ER EN
YDERST ÆTSENDE SYRE.**

- Kontrollér, om batteriladeren er frakoblet netforsyningen.
- Kontrollér batteriklemmernes polaritet: plus (symbolet +) og minus (symbolet -).
- BEMÆRK: Hvis symbolerne ikke er tydelige, skal man huske på, at plusklemmen er den, der ikke er forbundet til køretøjets chassis.

- Forbind den røde ladetang med batteriets plusklemme (symbolet +).
 - Forbind den sorte ladetang med bilens chassis, langt væk fra batteriet og brændstofføret.
- BEMÆRKNING: Hvis batteriet ikke er monteret i bilen, opprettes der en direkte forbindelse med batteriets minusklemme (symbol -).

5. GODE RÅD

- Rengør de positive og negative klemmer for eventuelle oxydaflejringer så der er god kontakt
- Hvis batteriladeren skal anvendes til et fastmonteret batteri i et køretøj, bør også køretøjets instruksjonsbok konsulteres, se under "ELANLÆG" eller "VEDLIGEHOLDELSE". Iden opladningen påbegyndes, er det god praksis at tage køretøjets elanlægs positive batterikabel fra batteriet.

(NO)



ADVARSEL: FØR DU BRUKER BATTERILADEREN SKAL DU LESE HÅNDBOKA NØYE!

1. GENERELLE FORHOLDSREGLER FOR BRUK AV DENNE BATTERILADEREN



- Under batteriladningen dannes det eksplosive gasser. Unngå farer som flammer og gnistdannelse. IKKE RØYK!
- Plasser batteriene på en plass med god ventilasjon for laddingsprosedyren.



- Personer uten erfaringer må instrueres før de bruker apparatet.
- Apparatet kan brukes av barn over 8 år og personer med reduserte fysiske, følelsesmessige eller mentale evner, eller som mangler erfaring og kunnskap, så lenge de er under oppsyn eller har blitt instruert i sikker bruk av apparatet og forstår farene det innebærer.
- Barn må ikke leke med apparatet.
- Barn må ikke foreta rengjørings- eller vedlikeholdsoppgaver uten å være under oppsyn.
- Støpslet må alltid tas ut av kontakten for nettilkoplingen før du kople ladekablene fra eller til batteriet.
- Du skal aldri kople eller frakople tengene til batteriet med batteriladeren igang.
- Batteriladeren må absolutt ikke brukes inne i en bil eller i bagasjerommet.
- Strømtilførselskabelen må kun skiftes ut med en originalkabel.
- Hvis strømledningen er ødelagt, må denne skiftes ut av produsenten eller produsentens servicetjeneste eller uansett av en person med lignende kvalifikasjoner, for slik at all risiko kan unngås.
- Batteriladeren må ikke brukes til batterier som ikke er oppladbare.
- Kontroller at tilgjengelig strømspenning tilsvarer verdiet som er indikert på

batteriladerens skilt da du bruker batteriladeren for ladning og oppstart; dette gjelder også for indikasjonene som batterifabrikanten forsyner.

- For å ikke skade kjøretøyets elektroniske seksjon, slå du lese, oppbevar og nøye følge advarselingene som fabrikanten forsyner sammen med kjøretøyene.
- Denne batteriladeren inneholder deler som strømbryter og rele' som kan lage lysbuer eller gnister. Når laderen brukes på et bilverksted eller lignende, bør den plasseres på et sikkert og hensiktsmessig sted.
- Reparasjons- og vedlikeholdsarbeid må batteriladeren må kun utføres av fagpersonell.



KOBLE ALLTID FORSYNINGSKABELENE FRA NETTET FØR DU UTFØRER ETHVERT VEDLIKEHOLDSSINGREP PÅ BATTERILADEREN.

2. INTRODUKSJON OG GENERELL BESKRIVELSE

- Denne batteriladeren gjør det mulig å lade blybatterier med fri elektrolytt, hermetisk lukket og med litium brukt i motorkjøretøy (bensin og diesel), motorsykler, båter, etc.
- Oppladbare akkumulatorer basert på tilgjengelig uttakspenning: 6V, 12V og 24V (ifølge skiltdata).
- Denne batteriladeren, avhengig av modellen, kan ha 230V 50/60Hz eller 110V 50/60Hz enfaset forsyning (ifølge skiltdata). Ladestrømmen og spenningen som mates elektronisk ved apparatet og følger IU eller U-ladeturven.
- Utstyr som følger med:
 - Apparatet gjør det mulig å koble til ulike typer ledninger for lading av batteriene i uttakene:
 - ledninger utstyrt med hull;
 - ledninger utstyrt med klemmer.

3. INSTALLASJON Plassering av BATTERILADEREN

- Under bruk må du plassere batteriladeren slik at den står stabilt.
- Unngå å løfte opp batteriladeren via strømledningen eller ladeledningen.

TILKOBLING TIL STRØMNETTET

- Batteriladeren må bare kobles til et strømsystem med nøytral leder koblet til jord. Kontroller at nettverksspenningen er lik driftspenningen.
- Forsyningslinjen må være utstyrt med sikringssystemer, enten sikringer eller automatiske brytere, som tåler apparatets maksimale absorpsjon (ifølge skiltdata).
- Koblingen til strømmettet må skje med egnet strømledning.
- Eventuelle skjøteledninger ved strømledningen må ha en tilstrekkelig seksjon og må uansett aldri være mindre enn apparatets strømledning.

4. FUNKSJON FORBEREDELSE FØR LADING

- NB: Før du utfører ladingen, må du kontrollere at kapasiteten ved batteriet (Ah) som du vil lade ikke er mindre enn den som indikeres på ID-skiltet ved batteriladeren (C min).
- Utfør instruksjonene nøye ifølge ordren nedenfor.
- Ta av dekslene på batteriet (hvis det finnes),

slik at gassene som produseres under ladningen kan komme ut.

- Kontroller at elektrolyttnivået dekker batteriplatene; hvis de ikke er dekt skal du tilsette vann til de er dekt til 5 -10 mm.

 **ADVARSEL! UTVIS EKSTREM FORSIKTIGHET UNDER DENNE OPERASJONEN DA ELEKTROLYTTBUFFERREAGENS ER EN STERKT ETSENDE SYRE.**

- Kontroller at batteriladeren er koblet fra strømmettet.

- Kontroller polariteten for batteripolene: positiv (symbol +) og negativ (symbol -).

MERK: Dersom symbolene ikke er preget, vær oppmerksom på at den positive terminalen ikke er koblet til maskinrammen.

- Koble den røde ladeklemmen til batteriets positive pol (symbol +).

- Koble den svarte ladeklemmen til maskinens ramme, på avstand fra batteriet og drivstoffkanalen.

MERK: hvis batteriet ikke er installert i kjøretøyet, må man koble direkte til batteriets negative klemme (symbol -).

5. GODE RÅD

- Gjør ren batteripolene for eventuelle oksidbelegg, slik at det oppnås god kontakt.
- Skal batteriladeren brukes til et fast montert batteri i et kjøretøy, må dette kjøretøyets instruksjonsbok kontrolleres, se under "ELUTSTYR" eller "VEDLIKEHOLD". Før ladningen startes opp er det fornuftig å kople den positive batterikabelen fra batteriet.

(SL)



OPOZORILO: PREDEN ZAČNETE UPORABLJATI POLNILNIK AKUMULATORJEV, POZORNO PREBERITE PRIROČNIK ZA UPORABO!

1. SPLOŠNA VARNOST ZA UPORABO TEGA POLNILNIKA AKUMULATORJEV



- Med polnjenjem akumulatorjev se sproščajo eksplozivni plini, zato pazite, da ne bo prišlo do plamena ali isker. **NE KADITE.**

- Akumulatorje, ki se polnijo, postavite na prezračeno mesto.



- **Neizkušeno osebje je treba pred uporabo naprave primerno poučiti.**
- **Napravo smejo otroci, ki starejši od 8 let, osebe z zmanjšanimi fizičnimi, čutnimi ali umskimi zmožnostmi, ali osebe, ki z njo nimajo izkušenj ali je ne poznajo, uporabljati le pod nadzorom odraslih oseb, ki so dobile navodila o varni rabi naprave, ter so razumele, kakšno nevarnost lahko povzroča naprava.**
- **Otroci se z napravo ne smejo igrati.**
- **Čiščenja in vzdrževanja, ki ju mora izvajati uporabnik, ne smejo izvajati otroci brez nadzora..**
- Napajalni kabel iztaknite iz omrežja, preden

priključite ali snamete kable za polnjenje na akumulator ali z njega.

- Ne odklopite ali priklopite klešč na akumulator, ko ta deluje.

- V nobenem primeru ne uporabljajte polnilnika za akumulatorje v notranjosti vozila ali pod pokrovom motorja.

- Napajalni kabel nadomestite le z originalnim kablom.

- Če je napajalni kabel poškodovan, ga mora zamenjati proizvajalec ali njegov tehnični servisni center ali podobno usposobljena oseba, tako da ne bi prišlo do kakršnih koli tveganj.

- Ne uporabljajte polnilnika akumulatorjev za polnjenje baterij, ki se ne smejo polniti.

- Preverite, da napajalna napetost, ki je na razpolago, ustreza tisti, ki je navedena na ploščici s podatki polnilnika akumulatorjev.

- Da ne bi poškodovali elektronike vozil, preberite, shranite in skrbno upoštevajte opozorila proizvajalcev vozil, ko uporabljate polnilnik akumulatorjev za polnjenje ali za zagon; enako velja za navedbe proizvajalca akumulatorjev.

- Ta polnilnik za akumulatorje zajema dele, kot so stikala ali releji, ki lahko povzročijo električni lok ali iskro; če ga torej uporabljate v garaži ali podobnem okolju, postavite polnilnik akumulatorjev v poseben prostor ali v primerno ohišje.

- Posege za popravila in vzdrževanje v notranjosti polnilnika akumulatorjev sme izvajati le izkušeno osebje.

 **VEDNO IZKLJUČITE NAPAJALNI KABEL IZ OMREŽJA, PREDEN ZAČNETE IZVAJATI KAKRŠNE KOLI POSEGE VZDRŽEVANJA POLNILNIKA AKUMULATORJEV.**

2. UVOD IN SPLOŠNI OPIS

- Ta polnilnik akumulatorjev omogoča polnjenje svinčevih akumulatorjev s prostim elektrolitom, hermetično zaprtih akumulatorjev in litijevih akumulatorjev, ki se uporabljajo v motornih vozilih (bencinskih in dizelskih), na motorjih, plovilih itd.

- Akumulatorji za polnjenje z naslednjimi razpoložljivimi napetostmi: 6V, 12V in 24V (v skladu s ploščico s podatki).

- Ta polnilnik akumulatorjev lahko glede na model omogoča enofazno napajanje 230V 50/60Hz ali 110V 50/60Hz (v skladu s ploščico s podatki).

Tok in napetost za polnjenje, ki ju dovaja naprava, sta elektronsko krmiljena in sledita krivulji polnjenja IU ali U.

- Serijsko priložena oprema:
 - Naprava omogoča na izhodu povezovanje različnih kablov za polnjenje akumulatorjev:
 - kabli, opremljeni z ušesici;
 - kabli, opremljeni s kleščami).

3. NAMESTITEV

UMESTITEV POLNILNIKA AKUMULATORJEV

- Med delovanjem naj bo polnilnik akumulatorjev postavljen stabilno.

- Izogibajte se dviganju polnilnika akumulatorjev za napajalni kabel ali kabel za polnjenje.

PRIKLJUČITEV V OMREŽJE

- Polnilnik akumulatorjev se lahko priključi izključno v napajalni sistem, ki ima ozemljeno ničlo.



UPOZORNENIE: PRED POUŽITÍM NABÍJAČKY AKUMULÁTOROV SI POZORNE PREČÍTAJTE NÁVOD NA POUŽITIE!

1. ZÁKLADNÉ BEZPEČNOSTNÉ POKYNY PRE POUŽITIE TEJTO NABÍJAČKY AKUMULÁTOROV



- Počas nabíjania sa z akumulátorov uvoľňujú výbušné plyny, a preto zabráňte vzniku plameňov a iskier. NEFAJČITE.
- Umiestnite nabíjané akumulátory do vetraného priestoru.



- **Osoby, ktoré nemajú skúsenosti so zariadením, by mali byť pred jeho používaním vhodne vyškolené.**
- **Zariadenie môžu používať deti, ak majú najmenej 8 rokov, a osoby so zníženými fyzickými, zmyslovými alebo mentálnymi schopnosťami, alebo osoby bez skúseností alebo potrebných znalostí, za predpokladu, že sú pod dozorom, alebo že im boli poskytnuté pokyny ohľadom bezpečného použitia zariadenia a ohľadom pochopenia súvisiacich nebezpečenstiev.**
- **Deti sa nesmú so zariadením hrať.**
- **Čistenie a údržbu zariadenia, ktoré má vykonať užívateľ, nesmú vykonávať deti bez dozoru.**
- Pred zapojením alebo odpojením nabíjajúcich káblov od akumulátora odpojte napájací kábel zo siete.
- Nepripájajte ani neodpájajte kliešte ku/ od akumulátora počas činnosti nabíjačky akumulátorov.
- V žiadnom prípade nepoužívajte nabíjačku akumulátorov vo vnútri vozidla alebo v priestore motora.
- Napájací kábel nahradte iba originálnym káblom.
- Keď je napájací kábel poškodený, musí byť vymenený výrobcom alebo jeho servisnou službou, alebo osobou s podobnou kvalifikáciou, aby sa zabránilo akémukoľvek riziku.
- Nepoužívajte nabíjačku akumulátorov pre nabíjanie nenabíjateľných akumulátorov.
- Skontrolujte, či napájacie napätie, ktoré je k dispozícii odpovedá napätiu uvedenému na identifikačnom štítku nabíjačky akumulátorov.
- Aby ste pri použití nabíjačky akumulátorov na nabíjanie aj na štartovanie nepoškodili elektroniku vozidiel, pozorne si prečítajte, uschovajte a dodržiujte upozornenie dodané výrobcom samotných vozidiel; to isté aj pre pokyny dodané výrobcom akumulátorov.
- Súčasťou tejto nabíjačky akumulátorov sú komponenty, ako napr. vypínače alebo relé, ktoré môžu vyvolať vznik oblúku alebo iskry; preto pri použití nabíjačky akumulátorov v autodielni alebo v podobnom prostredí, uložte nabíjačku do miestnosti alebo do obalu vhodného na tento účel.
- Zásahy do vnútorných častí nabíjačky

Preverite, da je omrežna napetost enaka delovni napetosti.

- Napajalna linija mora biti opremljena z zaščitnimi sistemi, kot so varovalke ali samodejna stikala, ki morajo biti dovolj močni, prestrežejo maksimalno absorpcijo naprave (v skladu s ploščico s podatki).
- Priključitev v omrežje je treba izvesti z ustreznim kablom.
- Morebitni podaljški napajalnega kabla morajo imeti ustrezen prerez in ne smejo biti tanjši od napravi priloženega kabla.

4. DELOVANJE

PRIPRAVA NA POLNENJE

OPOZORILO: Pred polnjenjem preverite, da zmogljivost akumulatorja (Ah), ki ga želite napolniti, ni manjša od tiste, ki je navedena na identifikacijski ploščici (C min).

Korake navodil skrbno izvedite v navedenem vrstnem redu.

- Če so nameščeni, odstranite pokrovčke na akumulatorju, tako da lahko normalno uhajajo plini, ki nastajajo med polnjenjem v akumulatorju.
- Preverite, da elektrolit pokriva plošče v akumulatorju; če gledajo ven iz elektrolita, dolijte destilirano vodo, dokler ne sega gladina za 5-10 mm nad plošče.



POZOR! PRI TEM PAZITE, SAJ JE ELEKTROLIT IZJEMNO KOROZIVNA KISLINA.

- Preverite, da je polnilnik akumulatorjev izključen iz omrežja.
- Preverite polariteto priključkov na akumulatorju: pozitiven (simbol +) in negativen (simbol -).

POZOR: če simboli niso več razločni, si zapomnite, da je pozitivni priključek tisti, ki ni povezan z ohišjem avtomobila.

- Priključite klešče za polnjenje rdeče barve na pozitivni priključek akumulatorja (simbol +).
- Priključite klešče za polnjenje črne barve na ohišje vozila, stran od akumulatorja in od vodov za dovajanje goriva.

POZOR: če akumulator ni v vozilu, klešče črne barve povežite neposredno na negativni priključek akumulatorja (simbol -).

5. UPORABNI NASVETI

- Očistite pozitivni in negativni pol morebitnih rjastih oblog, tako da zagotovite dober oprijem klešč.
- Če je akumulator, na katerem nameravate uporabiti polnilnik, stalno nameščen na vozilu, preberite tudi priročnik z navodili ali za vzdrževanje vozila, poglavje "ELEKTRIČNA NAPELJAVA" ali "VZDRŽEVANJE". Bolje je, če pred polnjenjem izklopite pozitivni kabel, ki je del električne napeljave vozila.

akumulátorov v rámci opráv alebo údržby môže vykonať už len skúsený personál.



PRED VYKONANÍM AKÉHOKOLVEK ÚKONU ÚDRŽBY NABÍJAČKY AKUMULÁTOROV, ODPOJTE NAPÁJACÍ KÁBEL Z ELEKTRICKEJ SIETE.

2. ÚVOD A ZÁKLADNÝ POPIS

- Táto nabíjačka akumulátorov umožňuje nabíjanie olovených akumulátorov s voľným elektrolytom, hermeticky uzavretých a lítiových akumulátorov, používaných v motorových vozidlách (benzínových aj naftových), motocykloch, plavidlách, atď.
- Akumulátory nabíjateľné v závislosti od daného výstupného napätia: 6V, 12V + 24V, (v závislosti na parametroch na štítku s technickými údajmi).
- Táto nabíjačka akumulátora môže byť, v závislosti na modeli, usporiadaná pre jednofázové napájanie 230 V~ - 50/60 Hz alebo 110 V~ - 50/60 Hz (v závislosti na parametroch na štítku s technickými údajmi). Nabíjací prúd a napätie, ktoré zariadenie dodáva, sú riadené elektronicky a sledujú nabíjajúcu krivku IU alebo U.
- Štandardná výbava:
 - Zariadenie umožňuje pripojiť na výstup rôzne druhy káblov pre nabíjanie akumulátorov:
 - káble s očkami;
 - káble s kliešťami.

3. INŠTALÁCIA

UMIESTNENIE NABÍJAČKY

- Počas činnosti musí byť nabíjačka umiestnená stabilným spôsobom.
- Zabráňte dvíhaniu nabíjačky akumulátorov prostredníctvom napájacieho kábla alebo nabíjacieho kábla.

PRIPOJENIE DO ELEKTRICKEJ SIETE

- Nabíjačka akumulátorov musí byť pripojená výhradne k napájaciemu systému s uzemneným nulovým vodičom. Skontrolujte, či napätie siete odpovedá prevádzkovému napätiu.
- Napájacie vedenie bude musieť byť vybavené ochrannými systémami, ako napr. poistkami alebo automatickými vypínačmi, schopnými znášať maximálnu prúdovú záťaž zariadenia (v závislosti na parametroch na štítku s technickými údajmi).
- Pripojenie do siete musí byť vykonané použitím príslušného kábla.
- Prípadné predlžovacie káble napájacieho kábla musia mať vhodný prierez, ktorý nesmie byť v žiadnom prípade menší než prierez dodaného kábla.

4. ČINNOSŤ

PRÍPRAVA NA NABÍJANIE

POZN.: Pred nabíjaním sa presvedčte, či kapacita akumulátorov (Ah), ktoré chcete nabíjať, nie je nižšia ako kapacita uvedená na identifikačnom štítku (C min).

Vykonajte jednotlivé úkony, pričom striktné dodržujte nižšie uvedený postup.

- Odmontujte zátky akumulátorov (ak sú súčasťou), aby sa mohli uvoľniť plyny vznikajúce pri nabíjaní.
- Skontrolujte, či hladina elektrolytu zakrýva dosky akumulátora; v prípade, že sú odhalené, dolejte destilovanú vodu tak, aby zostali ponorené 5-10 mm.



UPOZORNENIE! VENUJTE TEJTO OPERÁCII MAXIMÁLNU POZORNOSŤ, PRETOŽE KYSELINA V ELEKTROLYTE JE VYSOKO KOROZÍVNA.

- Skontrolujte, či je nabíjačka akumulátorov odpojená od siete.
- Skontrolujte polaritu svoriek akumulátora: kladný pól so symbolom + a záporný pól so symbolom -.
POZNÁMKA: Keď sa symboly nezhodujú, pamätajte, že kladný pól je ten, ktorý nie je pripojený k podvozku auta.
- Pripojte nabíjacie kliešte červenej farby ku kladnému pólu akumulátora (symbol +).
- Pripojte nabíjacie kliešte čiernej farby k podvozku auta, v dostatočnej vzdialenosti od akumulátora a od palivového rozvodu.
POZNÁMKA: Ak nie je akumulátor nainštalovaný v aute, pripojte kábel priamo k zápornej svorke akumulátora (symbol -).

5. PRAKTICKÉ RADY

- Vyčistite zápornú a kladnú svorku od možných nánosov oxidu, aby ste zaistili dobrý kontakt kliešti.
- Keď je akumulátor, ktorý sa má nabíjať nabíjačkou, pevne vložený do vozidla, oboznámte sa aj s návodom na použitie a/alebo údržbu vozidla, konkrétne s časťou „ELEKTROINŠTALÁCIA“ alebo „ÚDRŽBA“. Pred nabíjaním je vhodné odpojiť kladný kábel, tvoriaci súčasť elektroinštalácie vozidla.

(HU)



FIGYELEM: AZ AKKUMULÁTORTÖLTŐ HASZNÁLATA ELŐTT FIGYELMESEN OLVASSA EL A HASZNÁLATI UTASÍTÁST!

1. ÁLTALÁNOS BIZTONSÁGI ELŐÍRÁSOK AZ AKKUMULÁTORTÖLTŐ HASZNÁLATÁHOZ



- A töltés folyamán az akkumulátorok robbanó gázokat bocsátanak ki, akadályozza meg a lángok és szikrák kialakulását. NE DOHÁNYOZZON.
- Helyezze a töltés alatt lévő akkumulátorokat egy szellős helyre.



- **A tapasztalatlan személyeket idejében, a készülék használatba vétele előtt be kell tanítani.**
- **A készüléket 8 évesnél nagyobb gyermekek és csökkent fizikai, érzékszervi vagy szellemi képességű, illetve tapasztalattal és a szükséges ismeretekkel nem rendelkező személyek felügyelet mellett használhatják, vagy azt követően, hogy a készülék biztonságos használatára vonatkozó utasításokat megkapták és az azzal kapcsolatos veszélyeket megértették.**
- **A gyermekek nem játszhatnak a készülékkel.**
- **A felhasználó által elvégezendő tisztítást és karbantartást gyermekek felügyelet nélkül nem hajthatják végre.**

- Húzza ki a tápkábelt a hálózathoz, mielőtt csatlakoztatja vagy leveszi a töltőkábeleket az akkumulátorról.
- Ne csatlakoztassa vagy ne vegye le a csipeszeket az akkumulátorról, amikor az akkumulátortöltő működik.
- Semmi esetre se használja az akkumulátortöltőt egy gépjármű belsejében vagy a motortérben.
- A tápkábelt csak eredeti kábelre cserélje le.
- Ha a tápkábel sérült, akkor azt a gyártónak vagy a műszaki szervízszolgálatának vagy mindenestre hasonló szakképesítéssel rendelkező személynek kell elvégeznie bármiféle kockázat megelőzése érdekében.
- Ne használja az akkumulátortöltőt nem tölthető típusú akkumulátorok töltésére.
- Vizsgálja meg, hogy a rendelkezésre álló tápfeszültség megfelel-e az akkumulátortöltő adattábláján megjelölt tápfeszültségnek.
- Olvassa el, őrizze meg és gondosan tartsa be a járművek gyártói által nyújtott figyelmeztető előírásokat azért, hogy a járművek elektronikája ne károsodjon, amikor az akkumulátortöltőt akár töltésre, akár hidegindításra használja; ugyanez érvényes az akkumulátorgyártó által nyújtott utasításokra vonatkozóan is.
- Ez az akkumulátortöltő olyan részeket tartalmaz, mint a kapcsolók vagy relék, amelyek ívet vagy szikrákat válthatnak ki; ezért ha egy autógarázsban vagy hasonló környezetben használja, akkor a célnak megfelelő helyiségbe vagy védőházba helyezze az akkumulátortöltőt.
- Az akkumulátortöltő belsejében javítási vagy karbantartási beavatkozásokat csak tapasztalt dolgozó végezhet el.



MINDIG HÚZZA KI A TÁPKÁBELT A HÁLÓZATBÓL BÁRMILYEN KARBANTARTÁSI BEAVATKOZÁS ELVÉGZÉSE ELŐTT AZ AKKUMULÁTORTÖLTŐN.

2. BEVEZETÉS ÉS ÁLTALÁNOS LEÍRÁS

- Ez az akkumulátortöltő lehetővé teszi motoros járműveken (benzines és dízel), motorkerékpárokon, hajókon stb. használatos, folyékony elektrolitú, légmentesen zárt és lítiumos ólomakkumulátorok töltését.
- A rendelkezésre álló kimeneti feszültség függvényében újratölthető akkumulátorok: 6V, 12V és 24V (adattáblázat alapján).
- Ez az akkumulátortöltő egyfázisú, a modelltől függően 230V 50/60Hz vagy 110V 50/60Hz (adattáblázat alapján) tápellátású lehet.
- A készülék által leadott töltőáram és -feszültség elektronikusán irányított és az IU vagy U töltési görbét követi.
- Széria tartozékok:
 - A készülék kimenetéhez különféle típusú kábelek csatlakoztatása lehetséges az akkumulátorok töltéséhez:
 - gyűrű terminállal ellátott kábelek;
 - csípszel ellátott kábelek.

3. ÖSSZESZERELÉS AZ AKKUMULÁTORTÖLTŐ ELHELYEZÉSE

- A működés idejére helyezze az akkumulátortöltőt stabil helyre.
- Kerülje az akkumulátortöltő tápkábelnél vagy a töltőkábelnél való felemelését.

BEKÖTÉS A HÁLÓZATBA

- Az akkumulátortöltőt kizárólag egy földelt,

semleges vezetékkel kell egy táprendszerbe csatlakoztatni.

Ellenőrizze, hogy a hálózati feszültség azonos-e a működési feszültséggel.

- A tápvonalnak olyan védelmi rendszerekkel kell rendelkeznie, mint biztosítékok vagy automata megszakítók, amelyek alkalmasak a készülék maximális áramfelvételének elviseléséhez (adattáblázat alapján).
- A hálózathoz való csatlakoztatást arra alkalmas kábelrel kell elvégezni.
- Az esetleges tápkábel-hosszabbítók a tartozékként nyújtott kábelnek megfelelő és mindenestre annál sohasem kisebb keresztmetszetűek legyenek.

4. MŰKÖDÉS

ELŐKÉSZÍTÉS A TÖLTÉSHEZ

MEGJ.: A töltés megkezdése előtt ellenőrizni kell, hogy a feltöltendő akkumulátorok kapacitása (Ah) nem kisebb a táblán feltüntetetté (C min). Hajtsa végre az utasításokat az alul feltüntetett sorrend gondos betartása mellett.

- Távolítsa el az akkumulátor fedeleit (ha vannak), így a töltés folyamán képződő gázok kiáramolhatnak.
- Ellenőrizze, hogy az elektrolit szintje ellepje az akkumulátor lemezeket; ha azok nincsenek takarva, akkor öntsön be annyi desztillált vizet, hogy a lemezek 5 - 10 mm-ig belemerüljenek.



FIGYELEM! A LEGNAGYOBB ÓVATOSSÁGGAL JÁRJON EL E MŰVELET FOLYAMÁN, MIVEL AZ ELEKTROLIT EGY NAGYMÉRTÉKBEN KORROZÍV HATÁSÚ SAV.

- Vizsgálja meg, hogy az akkumulátortöltő ki legyen csatlakoztatva a hálózathoz.
- Vizsgálja meg az akkumulátor saruk polaritását: pozitív (+ jel) és negatív (- jel).
- MEGJEGYZÉS: ha a jelek nem különböztethetők meg, akkor emlékezzen arra, hogy a pozitív saru az, amelyik nincs csatlakoztatva a jármű vázához.
- Csatlakoztassa a piros színű töltőcsipeszt az akkumulátor pozitív sarujához (+ jel).
- Csatlakoztassa a fekete színű töltőcsipeszt a gépkocsi vázához, az akkumulátortól és az üzemanyagcsőtől távol.
- MEGJEGYZÉS: ha az akkumulátor nincs beszerelve a gépkocsiba, akkor csatlakoztassa közvetlenül az akkumulátor negatív sarujához (- jel).

5. HASZNOS TANÁCSOK

- Tisztítsa meg a pozitív és negatív kapcsokat a lehetséges oxidlerakódásoktól, biztosítva ezáltal a csipeszek megfelelő érintkezését.
- Ha az akkumulátortöltővel feltöltendő akkumulátor állandóan csatlakoztatva van egy járműhöz, akkor olvassa el a jármű felhasználói és/vagy karbantartási kézikönyvében is az "ELEKTROMOS HÁLÓZAT" vagy a "KARBANTARTÁS" címszó alatti részeket. Lehetséges szerint csatlakoztassa ki a töltés megkezdése előtt a jármű elektromos hálózatának részét képező pozitív kábelt.

INSTRUKCIJŲ KNYGELĖ



ĮSPĖJIMAS: PRIEŠ NAUDOJANT AKUMULIATORIAUS ĮKROVIKLĮ, ATIDŽIAI PERSKAITYTI INSTRUKCIJŲ VADOVĄ!

1. BENDRI ŠIO AKUMULIATORIAUS ĮKROVIKLIO NAUDOJIMO SAUGOS REIKALAVIMAI



- Įkrovimo metu akumulatoriai išleidžia sprogstamas dujas, venkite liepsnų ir žiežirbų susiformavimo. **NERŪKYTI.**
- Įkraunamas akumulatorius turi būti padėtas gerai vėdinamoje vietoje.



- **Patyrimo neturintys asmenys, prieš naudodami prietaisą, turi būti tinkamai apmokyti.**

- **Vaikams nuo 8 metų amžiaus ir asmenims su ribotais fiziniais, juliniais arba protiniais gebėjimais arba asmenims, neturintiems pakankamai patirties ir žinių, šį įrenginį leidžiama naudoti tik prižiūrint kitam asmeniui arba jei jie buvo apmokyti kaip saugiai naudotis įrenginiu ir supranta apie galimus pavojus.**

- **Vaikams žaisti su įrenginiu draudžiama.**
- **Vaikams atlikti valymo ir naudotojų skirtus techninės priežiūros darbus, jei neprižiūri kitas asmuo, draudžiama.**

- Prieš sujungiant ar atjungiant akumulatoriaus įkrovimo laidus, ištraukti iš lizdo maitinimo laidą.

- Neprijunginėti bei neatjunginėti gnybtų prie akumulatoriaus, kai veikia įkroviklis.

- Jokiais būdais nenaudokite akumulatoriaus įkroviklio važiavimo priemonės arba kėbulo viduje.

- Esant reikalui, maitinimo laidą pakeisti tik nauju originaliu laidu.

- Jei maitinimo kabelis yra pažeistas, gamintojas arba jo įgaliotas techninio aptarnavimo centras turi jį pakeisti nauju, bet kokiu atveju šį darbą privalo atlikti tik panašios kvalifikacijos asmuo, tokiu būdu bus išvengta bet kokios rizikos.

- Niekada nenaudoti akumulatoriaus įkroviklio pakartotinai nepakraunamų akumuliatorių įkrovimui.

- Patikrinti, ar disponuojama maitinimo įtampa atitinka dydį, nurodytą ant akumulatoriaus įkroviklio duomenų plokštelės.

- Siekiant nesugadinti transporto priemonių elektronikos įtaisų, perskaityti ir išsaugoti automobilių gamintojų įspėjimus, bei nepriekaištingai jų laikytis. Ši taisyklė galioja naudojant akumulatoriaus įkroviklį tiek įkrovimo, tiek paleidimo metu. Tas pats galioja ir akumulatoriaus gamintojų nurodymams.

- Šiame akumulatoriaus įkroviklyje yra detalų, tokių kaip perjungikliai arba relės, kurios gali sąlygoti lankus arba žiežirbas, todėl, jeigu šis prietaisas yra naudojamas automobilių remonto dirbtuvėse arba panašioje aplinkoje, reikia padėti akumulatoriaus įkroviklį patalpoje ar kitoje tam tikslui pritaikytoje

vietoje.

- Akumulatoriaus įkroviklio taisymo arba techninės priežiūros darbai, atliekami šio prietaiso vidinėje dalyje, gali būti patikėti tik patyrusiam personalui.

! PRIEŠ ATLIEKANT BET KOKIUS AKUMULIATORIAUS ĮKROVIKLIO TECHNINĖS PRIEŽIŪROS VEIKSMUS, MAITINIMO KABLĮ VISADA ATJUNGTI NUO ELEKTROS ENERGIJOS TIEKIMO TINKLO.

2. ĮVADAS IR BENDRAS APRAŠYMAS

- Šis akumulatoriaus įkroviklis naudojamas švino akumuliatorių su laisvuju elektrolitu, sandariųjų ir ličio akumuliatorių, naudojamų variklinėse transporto priemonėse (varomose benzinu ir dyzeliu), motocikluose, vandens transporto priemonėse, ir t.t., įkrovimui.

- Įkraunami akumulatoriai pagal disponuojamą išėjimo įtampą: 6V, 12V ir 24V (žiūrėti duomenų lentelę).

- Šis akumulatoriaus įkroviklis, priklausomai nuo modelio, gali turėti 230V 50/60Hz arba 110V 50/60Hz (žiūrėti duomenų lentelę) vienfazį maitinimą.

Įkrovimo srovė ir įtampa, kurias tiekia įrenginys, yra kontroliuojamos elektroniniu būdu bei atitinka įkrovimo kreivę IU arba U.

- Standartinė įranga:

- Įrenginio išėjime galima prijungti įvairių tipų kabelius akumuliatorių įkrovimui:
 - kabelius su kilpomis;
 - kabelius su gnybtais.

3. ĮDIEGIMAS

AKUMULIATORIŲ ĮKROVIKLIO PASTATYMAS

- Eksploatavimo metu įkroviklį pastatyti stabiliai.

- Vengti įkroviklio pakėlimo jį suėmus už maitinimo kabelio arba įkrovimo kabelio.

PRIJUNGIMAS PRIE TINKLO

- Akumuliatorių įkroviklis turi būti prijungtas tik prie energijos tiekimo sistemos su neutraliu laidininku, prijungtu prie žemės.

- Patikrinti, ar tinklo įtampa atitinka įrenginio darbinę įtampą.

- Elektros tiekimo linija turėtų būti aprūpinta saugos sistemomis, tokiomis kaip lydieji saugikliai arba automatiniai grandinės pertraukikliai, kurių pakaktų maksimaliai įrenginio srovės absorbcijai (žiūrėti duomenų lentelę).

- Prijungimas prie tinklo turėtų būti atliekamas naudojant specialų kabelį.

- Galimi maitinimo kabelio ilgintuvai turi būti tinkamo skersmens, jis niekada negali būti mažesnis už tiekiamo kabelio skersmenį.

4. DARBAS

PASIRUOŠIMAS ĮKROVIMUI

SVARBU: Prieš pradėdamas įkrovimą, patikrinti, ar ketinamą įkrauti akumuliatorių talpa (Ah) nėra mažesnė už vertę, nurodytą duomenų lentelėje (C min).

Atlikti sujungimus kruopščiai laikantis žemiau nurodytos tvarkos.

- Nuimti akumulatoriaus kamščius (jei yra), tokiu būdu įkrovimo metu susidariusios dujos galės išeiti.

- Įsitikinti, ar elektrolito lygis dengia akumulatoriaus plokštes; jei taip nėra, papildyti distiliuoto vandens tiek, kad jos būtų apsemtos 5 - 10 mm.



DĒMESIO! ATKREIPTI YPATINGĄ DĒMESĮ ATLIKANT ŠIĄ OPERACIJĄ, NES ELEKTROLITAS YRA ITIN KOROZINĖ RŪGŠTIS.

- Patikrinti, ar akumuliatorių įkroviklis yra prijungtas prie tinklo.
- Patikrinti akumuliatorių gnybtų poliškumą: teigiamo (simbolis +) ir neigiamo (simbolis -).
PASTABA: jei simbolių neįmanoma atpažinti, atminti, kad teigiamas gnybtas yra tas, kuris nėra prijungtas prie automobilio važiuoklės.
- Prijungti raudonos spalvos įkrovimo gnybtą prie teigiamo akumuliatoriaus gnybto (simbolis +).
- Prijungti juodos spalvos įkrovimo gnybtą prie automobilio važiuoklės, toliau nuo akumuliatoriaus ir nuo degalų tiekimo sistemos.
PASTABA: jei akumuliatorius nėra įmontuotas automobilyje, prisijungti tiesiogiai prie neigiamo akumuliatoriaus gnybto (simbolis -).

5. NAUDINGI PATARIMAI

- Nuvalyti teigiamą ir neigiamą gnybtus nuo galimų oksidacijos apnašų, tokiu būdu bus užtikrintas geras gnybtų kontaktas.
- Jei akumuliatorius, su kuriuo ketinama naudoti šį įkroviklį yra stacionariai įstatytas transporto priemonėje, būtina peržiūrėti ir automobilio instrukcijų ir/arba techninės priežiūros vadovą, skyrių "ELEKTROS INSTALIACIJA" arba "TECHNINĖ PRIEŽIŪRA". Prieš pradėdant įkrovimą, patartina atjungti teigiamą laidą, kuris yra automobilio elektros instaliacijos dalis.

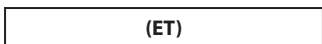

TÄHELEPANU: ENNE AKULAADIJA KASUTAMIST LUGEGE JUHISED HOOLIKALT LÄBI!

1. ÜLDINE TURVALISUS AKULAADIJA KASUTAMISEL



- Laadimisel eraldavad akud plahvatusohtlikke gaase; hoidke töötava laadija juurest eemal lahtine tuli ja sädemed. SUITSETAMINE KEELATUD
- Pange aku laadimise ajaks korralikult õhutatud ruumi.



- Vastavat kogemust mitteomavaid isikuid tuleb enne seadme kasutamist selle suhtes instrueerida.
- Seadet tohivad kasutada üle 8 aastased lapsed ja väikeste füüsiliste, sensoriaalsete või vaimsete puuetega inimesed, samuti kogemusteta ja vajalike teadmisteta inimesed, järelvalve all või peale seadme ohutut kasutamist ja sellest tulenevaid riske puudutava väljaõppe saamist.
- Lastel on keelatud seadmega mängida.
- Puhastus ja hooldus peavad olema läbi viidud kasutaja poolt, kuid mitte laste poolt ilma järelvalveta.
- Enne laadimiskaablite aku külge või selle

küljest lahti ühendamist ühendage laadija vooluvõrgust lahti.

- Ärge võtke näpitsaid aku klemmide küljest ära, kui laadija töötab.
- Rangelt on keelatud kasutada laadijat sõiduki sees või mootoriruumis.
- Toitejuhtme tohib asendada ainult uue originaaljuhtmega.
- Mis tahes riski vältimiseks tuleb toitekaabel, juhul, kui see on kahjutada saanud valmistaja või tema tehnilise abi teenuse poolt, igal juhul vastava ettevalmistuse saanud isiku poolt, välja vahetada.
- Akulaadijat ei tohi kasutada mitteleetavate akude laadimiseks.
- Kontrollige, et kasutatav toitepinge vastaks laadija infoplaadil äratoodule.
- Sõiduki elektroonikasüsteemide kahjustuste ärahoidmiseks tuleb laadija kasutamisel nii aku laadimiseks kui sõiduki käivitamiseks läbi lugeda, alles hoida ja rangelt järgida sõiduki valmistaja sellekohaseid nõudeid; sama kehtib aku valmistaja antud juhiste kohta.
- Laadija teatud osad (näiteks lülitid ja releed) võivad tekitada elektrikaari või sädemeid; seega tuleb laadija kasutamisel mehhaanikatöökojas või muudes samalaadsetes kohtades paigutada see sobilikku ruumi või hoiukohta.
- Parandus- või hooldustöid laadija sisemuses tohib teostada ainult vastava ala spetsialist.



ENNE IGAT HOOLDUSEGA SEOTUD TOIMINGUT AKULAADIJAL EEMALDAGE TOITEKAABEL VOOLUVÕRGUST.

2. SISSEJUHATUS JA ÜLDINE KIRJELDUS

- See akulaadija võimaldab laadida mootorsõidukites (bensiin ja diisel), mootorratastel, veesõidukites kasutatavaid vaba elektrolüüdiga pliiakusid, hermeetilisi ja liitiumakusid jne.
- Vastavalt saadaolevale väljundpingele taaslaetavad akud: 6V, 12V ja 24V (vastavalt andmeplaadile).
- See akulaadimisseade võib vastavalt mudelile olla 230V 50/60Hz või 110V 50/60Hz (vastavalt andmeplaadile) ühefaasiline.
Seadme poolt edastavat voolu ja laadimispinget kontrollitakse elektrooniliselt ja need järgivad laadimiskõverat IU või U.
- Standard varustus:
 - Seade võimaldab väljundis ühendada erinevaid aku laadimiseks kasutatavaid kaableid:
 - aasadega varustatud kaablid;
 - klambritega varustatud kaablid.

3. PAIGALDUS AKULAADIJA PAIGUTAMINE

- Töötamise ajal paigutage akulaadija stabiilselt paigale.
- Hoiduge akulaadija tõstmisest toitekaablit või laadimiskaablit kasutades.

VÕRKU ÜHENDAMINE

- Akulaadija peab olema ühendatud üksnes maandatud neutraalse juhiga toitesüsteemiga.
Veenduge, et võrgupinge oleks samaväärne tööpingega.
- Toiteliin peab olema varustatud kaitsesüsteemidega nagu sulavkaitsed või automaatlülitid, mis suudavad taluda seadme poolset maksimaalset neeldumist (vastavalt

andmeplaadile).

- Võrku ühendamine peab toimuma vastava kaabliga.
- Võimalikud toitekaabli pikendused peavad omama sobivat ristlõiget, mis ei tohi olla väiksem, kui varustusse kuuluval kaabliil.

4. FUNKTSIONEERIMINE

LAADIMISEKS VALMISTUMINE

NB: Enne laadimisega jätkamist kontrollige, et laaditavade akude võimsus (Ah) ei oleks väiksem numbriplaadil ära toodust (C min).

Instruktsioonide sooritamisel järgige alljärgnevat korda.

- Eemalda aku kaaned (kui on), nii et laadimise ajal tekkivad gaasid saaksid väljuda.

- Kontrollige, et elektrolüüdi tase kataks akude plaate; kui need on väljas, lisage 5 - 10 mm destilleeritud vett, kuni need on kaetud.

! TÄHELEPANU! NIMETATUD OPERATSIOONI AJAL TULEB OLLA ERITI HOOLIKAS, SEST ELEKTROLÜÜT ON ÄÄRMISELT SÖÖBIV.

- Kontrollige, et akulaadija oleks võrgust väljas.

- Kontrollige aku klemmide polarsust: positiivne (sümbol +) ja negatiivne (sümbol -).

MÄRKUS: kui sümbolid ei ole eristatavad, siis pidage meeles, et positiivne klemm on see, mis pole masina kerega ühendatud.

- Ühendage punast värvi laadimisklamber aku positiivse klemmiga (sümbol +).

- Ühendage musta värvi laasimisklamber masina kerega, eemale akust ja kütusejuhtmest.

MÄRKUS: kui akut pole masinasse paigaldatud, sooritage ühendus otse aku negatiivse klemmiga (sümbol -).

5. KASULIK TEADA

- Puhastage pluss-ja miinusklamid sinna kogunenud oksiidikihist, et kindlustada klambrite parem kontakt nendega.

- Kui soovitakse laadida akut, mida ei saa sõiduki küljest eemaldada, lugege lisaks käesolevale õpetusele läbi ka sõiduki kasutus- ja/või hooldusjuhendi peatükk "ELEKTRISEADMED" või "HOOLDUS". Enne laadima asumist oleks soovitatav lahti ühendada sõiduki elektrisüsteemi kuuluv plussjuhe.

(LV)



UZMANĪBU: PIRMS AKUMULATORU LĀDĒTĀJA IZMANTOŠANAS UZMANĪGI IZLASIET ROKASGRĀMATU!

1. VISPĀRĒJIE DROŠĪBAS NOTEIKUMI AKUMULATORU LĀDĒTĀJA LIETOŠANAI



- Uzlādēšanas laikā akumulatoros izdalās sprāgstošās gāzes, izvairieties no liesmu vai dzirksteļu veidošanas. **NESMĒĶĒJET.**

- Uzlādējiet akumulatorus labi vedināmā telpā.



- **Pirms ierīces lietošanas nepietiekoši kvalificētām personām jāiziet instruktāža.**

- **Šo ierīci drīkst izmantot bērni, sākot no 8 gadu vecuma, kā arī personas ar ierobežotām fiziskām, jutekliskām vai garīgām spējām un personas, kurām trūkst pieredzes un/vai zināšanu, ja viņus uzrauga cita persona vai, ja viņi ir instruēti par ierīces drošu izmantošanu un par riskiem, kas ar to saistīti.**

- **Bērni nedrīkst rotaļāties ar ierīci.**

- **Bērni bez uzraudzības nedrīkst veikt tīrīšanas vai paredzētās tehniskās apkopes operācijas.**

- Atvienojiet barošanas vadu no elektrotīkla pirms uzlādēšanas vada pievienošanas vai atvienošanas no akumulatora.

- Nepievienojiet un neatvienojiet spaiļes no akumulatora, kamēr akumulatoru lādētājs ir ieslēgts.

- Ir kategoriski aizliegts izmantot akumulatoru lādētāju, novietojot to transportlīdzeklī vai zem pārsegā.

- Nomainiet barošanas vadu tikai ar oriģinālo vadu.

- Ja barošanas vads ir bojāts, tā nomaīņa jāuztīra ražotāja vai servisa centra speciālistam vai personai ar līdzīgu kvalifikāciju, lai izvairītos no jebkādiem riskiem.

- Nelietojiet akumulatoru lādētāju tādu akumulatoru uzlādēšanai, kurus nav paredzēts uzlādēt.

- Pārbaudiet, vai pieejama barošanas avota spriegums atbilst akumulatoru lādētāja datu plāksnītē norādītajai vērtībai.

- Lai nesabojātu transportlīdzekļa elektroniku, izlasiet, saglabājiet un rūpīgi ievērojiet transportlīdzekļa ražotāja sniegtos norādījumus akumulatoru lādētāja lietošanas laikā, gan uzlādēšanas, gan iedarbināšanai; tas pats attiecas uz akumulatoru lādētāja ražotāja sniegtajiem norādījumiem.

- Šis akumulatoru lādētājs ietver tādas detaļas kā slēdži un releji, kuros var rasties elektriskie loki vai dzirksteles; tādējādi, lietojot to garāžā vai līdzīgā vietā, novietojiet akumulatoru lādētāju novietojiet akumulatoru lādētāju atbilstošajā vietā vai nodalījumā.

- Akumulatoru lādētāja labošana un tehniskā apkope ir jāuztīra kvalificētajam personālam.

! VIENMĒR ATVIENOJĒT BAROŠANAS VADU NO ELEKTROTĪKLA PIRMS JEBKĀDAS AKUMULATORU LĀDĒTĀJA APKOPES VEIKŠANAS.

2. IEVADS UN VISPĀRĪGS APRAKSTS

- Šis akumulatoru lādētājs ļauj lādēt svina akumulatorus ar brīvu elektrolītu, hermētiskus un litija akumulatorus, kurus izmanto automašīnās ar dzinējiem (benzīna un dīzeļa), motociklos, laivās u.c.

- Uzlādējamie akumulatori un to izejas spriegums: 6 V, 12 V un 24 V (saskaņā ar datu plāksnīti).

- Atkarībā no modeļa, šī akumulatoru lādētāju barošanai paredzēts izmantot vienfāzes 230 V 50/60 Hz vai 110 V 50/60 Hz tīklu (saskaņā ar datu plāksnīti).

lerīces padodamā uzlādes strāva un spriegums tiek kontrolēti elektroniski un seko IU vai U uzlādes liknei.

- Standartapriekojums:

- Ierīces izejai var pievienot dažāda veida akumulatoru uzlādes vadus:

- ar cilpām apriņķotus vadus;

- ar spailēm apriņķotus vadus.

3. UZSTĀDĪŠANA

AKUMULATORU LĀDĒTĀJA IZVIETOŠANA

- Sekojiet tam, lai darba laikā akumulatoru lādētājs būtu stabilā stāvoklī.
- Nepaceliet akumulatoru lādētāju aiz barošanas vada vai aiz uzlādēšanas vada.

PIESLĒGŠANA PIE TĪKLA

- Akumulatoru lādētāju drīkst pieslēgt tikai pie tādas barošanas sistēmas, kurai neitrālais vads ir iezemēts.
Pārbaudiet, vai elektrotīkla spriegums atbilst ierīces darba spriegumam.
- Barošanas līnijai jābūt aprīkoti ar aizsargsistēmām, tādām kā drošinātāji vai automātiskie slēdži, kas ir pietiekoši jaudīgi, lai izturētu ierīces maksimālo patērējamo strāvu (saskaņā ar datu plāksnīti).
- Ierīce jāsavieno ar elektrotīklu, izmantojot piemērotu vadu.
- Ja izmanto barošanas vada pagarinātājus, to šķērsgriezumam jābūt piemērotam un nekādā gadījumā tam nedrīkst būt mazākam par piegādātā vada šķērsgriezumu.

4. DARBĪBA

SAGATAVOŠANĀS UZLĀDĒŠANAI

IEVĒROJIET: Pirms uzlādēšanas pārbaudiet, vai uzlādējamo akumulatoru kapacitāte (Ah) nav zemāka par plāksnītē norādīto kapacitāti (C min).

Izpildiet norādījumus, rūpīgi ievērojot turpmāk izklāstīto kārtību.

- Noņemiet akumulatora vāciņus (ja tie ir), lai gāze, kas rodas uzlādēšanas laikā, varētu iziet ārā.
- Pārbaudiet, vai elektrolīts pārklāj akumulatoru plāksnes; ja tās ir atklātas, pievienojiet destilēto ūdeni līdz plāksnes ir iegremdētas 5–10 mm dziļumā.

 **UZMANĪBU! ESIET ĪPAŠI UZMANĪGS ŠĪS OPERĀCIJAS VEIKŠANAS LAIKĀ, JO ELEKTROLĪTS IR ĻOTI KODĪGA SKĀBE.**

- Pārbaudiet, vai akumulatoru lādētājs ir atvienots no elektrotīkla.

- Pārbaudiet akumulatora kontaktu polaritāti: pozitīvais (simbols +) un negatīvais (simbols -).

PIEZĪME: ja simbolus ir grūti atšķirt, atgādinām, ka pozitīvais kontakts ir tas, kurš nav savienots ar automašīnas šasiju.

- Savienojiet sarkano uzlādēšanas spaili ar akumulatora pozitīvo kontaktu (simbols +).

- Savienojiet melno uzlādēšanas spaili ar mašīnas šasiju, tālu no akumulatora un no degvielas caurules.

PIEZĪME: ja akumulators nav uzstādīts mašīnā, savienojiet to pa taisno ar akumulatora negatīvo spaili (simbols -).

5. NODERĪGI PADOMI

- Tiriet negatīvo un pozitīvo spaili, lai uz tām nebūtu rūsas, un lai nodrošinātu to labu vadītspēju.

- Ja akumulatoru, kuru ir paredzēts uzlādēt ar šo akumulatoru lādētāju, nevar noņemt no transportlīdzekļa, apskatiet transportlīdzekļa ekspluatācijas un/vai tehniskās apkopes rokasgrāmatas nodaļas "ELEKTROIEKĀRTA" vai "TEHNISKĀ APKOPE". Pirms uzlādēšanas sākuma tiek rekomendēts atslēgt pozitīvo vadu, kas ir transportlīdzekļa elektroiekārtas sastāvdaļa.

(BG)



ВНИМАНИЕ: ПРЕДИ ДА ИЗПОЛВАТЕ ЗАРЯДНОТО УСТРОЙСТВО, ПРОЧЕТЕТЕ ВНИМАТЕЛНО РЪКОВОДСТВОТО С ИНСТРУКЦИИ!

1. ОБЩА БЕЗОПАСНОСТ ПРИ УПОТРЕБА НА ТОВА ЗАРЯДНО УСТРОЙСТВО



- По време на зареждане акумулаторите отделят експлозивни газове, избягвайте образуването на пламъци и искри. ДА НЕ СЕ ПУШИ.

- Поставете акумулаторите да се зареждат на проветриво място.



- Неопитните лица трябва да получат съответното обучение преди да използват апарата.

- Апаратът може да бъде използван от деца на възраст над 8 години и лица с намалени физически, сензорни или умствени способности, или без необходимите познания, стига да са под наблюдение или след като същите са получили инструкции, свързани с безопасната употреба на апарата и са разбрали опасностите, произтичащи от употребата.

- Децата не трябва да играят с апарата.

- Почистването и поддръжката, които трябва да се извършват от потребителя, не трябва да се извършват от деца без наблюдение.

- Изключете захранващия кабел от мрежата преди да свържете или изключите кабелите за зареждане на акумулатора.

- Не свързвайте, нито махайте щипките на акумулатора при работещо зарядно устройство.

- Да не се използва изобщо зарядното устройство във вътрешността на автомобил или в кожата на двигателя.

- Подменяйте захранващия кабел само с оригинален кабел.

- Ако захранващият кабел е повреден, то той трябва да бъде подменен от производителя или от негов сервиз за техническо обслужване, или от лице с подобна квалификация, така че да се избегнат всякакви рискове.

- Не използвайте зарядното устройство, за да зареждате батерии, които са от тип, който не се зарежда.

- Проверете, дали захранващото напрежение, с което разполагате, отговаря на посоченото напрежение върху табелата с данни за зарядното устройство.

- За да не повредите електрониката на автомобилите, прочетете внимателно, съхранявайте и спазвайте стриктно предупрежденията, предоставени от производителите на самите автомобили, когато се използва зарядното устройство, както за зареждане така и за пусково устройство; същото се отнася и за указанията, предоставени от

производителя на акумулаторите.

- Това зарядно устройство съдържа части като прекъсвачи или релета, които могат да предизвикат образуването на дъги или искри; следователно ако се използва в гараж или в подобна среда, поставете зарядното устройство на място или кутия за съхранение, подходяща за целта.
- Операциите по поправка или поддръжка във вътрешността на зарядното устройство трябва да бъдат извършвани само от експертен персонал.



ИЗКЛЮЧАВАЙТЕ ВИАНИ ЗАХРАНВАЩИ КАБЕЛ ОТ МРЕЖАТА, ПРЕДИ ДА ИЗВЪРШВАТЕ, КАКВИТО И ДА Е ОПЕРАЦИИ ПО ПОДДРЪЖКА ВЪРХУ ЗАРЯДНОТО УСТРОЙСТВО ЗА АКУМУЛАТОРИ.

2. УВОД И ОБЩО ОПИСАНИЕ

- Това зарядно устройство позволява зареждането на оловни акумулатори със свободен електролит, херметични и литиеви акумулатори, използвани при автомобили с двигател (бензин и дизел), мотоциклети, лодки и т.н.
- Акумулатори, които се зареждат в зависимост от наличното изходно напрежение: 6V, 12V и 24V (според табелата с данни).
- Това зарядно устройство, в зависимост от модела, може да има монофазно захранване 230V 50/60Hz или 110V 50/60Hz (според табелата с данни).
Токът и напрежението за зареждане, отдавани от апарата, се управляват електронно и следват кривата на зареждане IU или U.
- Оборудване към серията:
 - Апаратът позволява да се свържат на изхода различни типове кабели за зареждане на акумулаторите:
 - кабел с крайник тип ухо;
 - кабели с щипки.

3. ИНСТАЛИРАНЕ

ПОСТАВЯНЕ НА ЗАРЯДНОТО УСТРОЙСТВО

- По време на функциониране поставете зарядното устройство в стабилно положение.
- Избягвайте повдигането на зарядното устройство чрез захранващия кабел или чрез кабела за зареждане.

СВЪРЗВАНЕ КЪМ МРЕЖАТА

- Зарядното устройство трябва да бъде свързано единствено със захранваща система с неутрален заземен проводник.
Проверете, дали напрежението на мрежата съответства на напрежението на функциониране.
- Захранващата линия трябва да е оборудвана със защитни системи като предпазители и автоматични прекъсвачи, достатъчни за да издържат при максимална консумация на апарата (според табелата с данни).
- Свързването към мрежата се осъществява със специалния кабел.
- Евентуални удължения на захранващия кабел трябва да са с подходящо сечение и все пак никога по-малко от това на предоставения кабел.

4. ФУНКЦИОНИРАНЕ

ПОДГОТОВКА ЗА ЗАРЕЖДАНЕ

ЗАБЕЛЕЖКА: Преди да пристъпите към зареждане, проверете, дали капацитета на акумулаторите (Ah), които възнамерявате да зареждате, не е по-малък от посочения на табелата (C min).

Изпълнете инструкциите като следвате стриктно реда, посочен по-долу.

- Отстранете капаците на акумулатора (ако има такива), така че газовете, които се образуват по време на зареждане, да могат да излизат.
- Проверете, дали нивото на електролита покрива пластините на акумулатора, ако се окажат непокрити добавете дестилирана вода, докато се потопят на 5 -10 mm.



ВНИМАНИЕ! БЪДЕТЕ ИЗКЛЮЧИТЕЛНО ВНИМАТЕЛНИ ПО ВРЕМЕ НА ТАЗИ ОПЕРАЦИЯ, ТЪЙ КАТО ЕЛЕКТРОЛИТЪТ Е СИЛНО КОРОЗИВНА КИСЕЛИНА.

- Проверете, дали зарядното устройство е изключено от мрежата.
- Проверете полярността на клемите на акумулатора: положителен (символ +) и отрицателен (символ -).
ЗАБЕЛЕЖКА: ако символите не се различават, напомниме, че положителната клемка, е тази, свързана за шасито на колата.
- Свържете щипката за зареждане с червен цвят към положителната клемка на акумулатора (символ +).
- Свържете щипката за зареждане черен цвят към шасито на леката кола, далеч от акумулатора и тръбите за горивото.
ЗАБЕЛЕЖКА: ако акумулаторът не е инсталиран в леката кола, свържете директно с отрицателната клемка на акумулатора (символ -).

5. ПОЛЕЗНИ СЪВЕТИ

- Почистете положителните и отрицателните клеми от вероятни наслоявания от окисления, така че да се осигури добър контакт на щипките.
- Ако акумулаторът, с който възнамерявате да използвате това зарядно устройство е постоянно поставен в превозното средство, направете справка с ръководството с инструкции и/или за поддръжка на превозното средство в глава "ЕЛЕКТРИЧЕСКА СИСТЕМА" или "ПОДДРЪЖКА". За предпочитане е да изключите, преди да пристъпите към зареждане, положителния кабел, който е част от електрическата система на автомобила.

(TR)



DİKKAT: AKÜ ŞARJ CİHAZINI KULLANMADAN ÖNCE, TALİMAT KILAVUZUNU DİKKATLE OKUYUN!

1. BU AKÜ ŞARJ CİHAZININ KULLANIMI İÇİN GENEL GÜVENLİK



- Aküler şarj işlemi sırasında patlayıcı gazlar çıkarılır, alev ve kıvılcımların oluşmasından kaçının. SİGARA İÇMEYİN.
- Şarj edilmekte olan aküleri havalandırılan bir yerde konumlandırın.



- **Deneyimsiz kişiler cihazı kullanmadan önce uygun şekilde eğitilmiş olmalıdır.**
- **Cihaz; 8 yaşından küçük olmayan çocuklar ve fiziksel, duyuşal veya zihinsel yetenekleri tam gelişmemiş kişiler veya cihazı hiç kullanmamış veya cihaz hakkında gerekli bilgiye sahip olmayan kişiler tarafından, sadece denetim altında tutuldukları sürece veya cihazın güvenlik içinde kullanımına dair ve bundan kaynaklanabilecek tehlikeleri anlayabilecek şekilde bilgilendirildikten sonra kullanılabilir.**
- **Çocuklar cihaz ile oynamamalıdır.**
- **Kullanıcı tarafından yapılması gereken temizlik ve bakım işlemleri, kendilerine nezaret eden biri olmadığı sürece çocuklar tarafından yapılmamalıdır.**

- Şarj kablolarını aküye bağlamadan veya aküden çıkarmadan önce güç besleme kablosunu şebekeden ayırın.
- Akü şarj cihazı işler durumda olduğunda, maşaları aküye bağlamayın ve aküden çıkarmayın.
- Akü şarj cihazını kesinlikle hiçbir şekilde bir aracın veya kaputun içinde kullanmayın.
- Güç besleme kablosunu sadece orijinal bir kablo ile değiştirin.
- Güç besleme kablosu hasar görmüş ise, her türlü riskin önlenmesi için kablonun üretici veya üreticinin teknik yardım servisi tarafından veya her halükarda benzer nitelikte bir kişi tarafından değiştirilmesi gerekir.
- Akü şarj cihazını yeniden şarj edilebilir tipte olmayan aküleri şarj etmek için kullanmayın.
- Mevcut güç besleme geriliminin akü şarj cihazının veri plakasında belirtilen gerilime karşılık geldiğini kontrol edin.
- Araçların elektroniğini hasara uğratmamak için, akü şarj cihazları gerek şarjda gerekse çalıştırmada kullanıldığında, araç üreticileri tarafından sağlanan uyarıları okuyun, saklayın ve bunlara titizlikle uyun; aynı durum akü üreticisi tarafından bilgiler için de geçerlidir.
- Bu akü şarj cihazı, arklara veya kıvılcımlara neden olabilecek şalterler veya röleler gibi parçalar içerir; bundan dolayı, bir garaj veya benzeri bir ortamda kullanılıyorsa, akü şarj cihazını amaca uygun bir mekana veya bir kutu içine koyun.
- Akü şarj cihazı içinde onarım veya bakım müdahaleleri sadece deneyimli personel tarafından yapılmalıdır.



AKÜ ŞARJ CİHAZI ÜZERİNDE HERHANGİ BİR BAKIM MÜDAHALESİ YAPMADAN ÖNCE DAİMA GÜÇ BESLEME KABLOSUNU ŞEBEKEDEN AYIRIN.

2. GİRİŞ VE GENEL TANIM

- Bu akü şarj cihazı, (benzin ve dizel) motorlu taşıtlarda, motosikletlerde, teknelerde vb. kullanılan serbest elektrolitli kurşun asit, hermetik ve lityum akülerin şarj edilmesini sağlar.
- Mevcut çıkış gerilimine göre yeniden şarj edilebilir akümülatörler: 6V, 12V ve 24V (veri plaka etiketine göre).
- Modele göre bu akü şarj cihazı, (veri plaka etiketine göre) 230V 50/60Hz veya 110V 50/60Hz tek fazlı besleme ile olabilir. Cihaz tarafından tedarik edilen şarj akımı ve gerilimi elektronik olarak kontrol edilir ve IU veya U şarj eğrisini izler.
- Standart donanımlar:
 - Cihaz, akülerin yeniden şarj edilmesi için çeşitli kablo tiplerinin çıkışa bağlanmasına olanak tanır:
 - Halka terminalli kablolar;
 - Maşalı kablolar.

3. KURULUM

AKÜ ŞARJ CİHAZININ KONUMU

- Akü şarj cihazını işleme sırasında sabit ve sağlam şekilde konumlandırın.
- Akü şarj cihazını güç besleme kablosu veya şarj kablosu aracılığıyla kaldırmaktan kaçının.

ŞEBEKEYE BAĞLAMA

- Akü şarj cihazı sadece toprağa bağlanmış nötr iletkenli bir güç besleme sistemine bağlanmalıdır.
- Şebeke geriliminin işleme gerilimine eşdeğerde olduğunu kontrol edin.
- Güç besleme hattı, cihazın maksimum emmesini karşılamak için yeterli olan sigortalar veya otomatik şalterler gibi koruma sistemleriyle donatılmış olmalıdır (veri plaka etiketine göre).
- Şebekeye bağlantı, özel kablo ile yapılmalıdır.
- Güç besleme kablosunun olası uzatmaları uygun bir kesite sahip olmalı ve her halükarda asla birlikte tedarik edilen kablounun kesitinden daha az olmamalıdır.

4. İŞLEME

ŞARJ İÇİN HAZIRLIK

ÖNEMLİ NOT: Şarj işlemine başlamadan önce, şarj edilmek istenen akülerin kapasitesinin (Ah) plaka etiketinde belirtilen (C min) kapasitesinin altında olmadığı kontrol edilmelidir.

Talimatları, titizlikle aşağıda belirtilen sırayı izleyerek uygulayın.

- Akü kapaklarını (mevcut ise), şarj işlemi sırasında üretilen gazların dışarı çıkmasını sağlamak amacıyla çıkarın.
- Akülerin plakalarını kaplayan elektrolit seviyesini kontrol edin; plakaların açıkta kalmış olduğunun görülmesi halinde, plakaların 5-10 mm kadar batmasını sağlayacak şekilde damıtılmış su ilave edin.



DİKKAT! ELEKTROLİT SON DERECE KORUZİF ETKİYE SAHİP BİR ASİT OLDUĞUNDAN, BU İŞLEM SIRASINDA AZAMI TEDBİR ALIN.

- Akü şarj cihazının şebekeden ayrılmış olduğunu kontrol edin.
- Akü terminallerinin kutuplarını kontrol edin:

pozitif (+ sembolü) ve negatif (- sembolü).

NOT: eğer semboller ayırt edilemiyorsa, pozitif terminalin aracın şasesine bağlı olmayan terminal olduğu hatırlatılır.

- Kırmızı renkli şarj maşasını akünün pozitif terminaline (+ sembolü) bağlayın.
- Siyah renkli şarj maşasını, aküden ve yakıt borusundan uzakta olarak aracın şasesine bağlayın.

NOT: eğer akü araç içine kurulmamış ise, doğrudan akünün negatif terminaline (- sembolü) bağlantı yapın.

5. FAYDALI TAVSİYELER

- Pozitif ve negatif terminalleri, maşaların iyi temas etmesini garantileyecek şekilde, mümkün oksit tabakalarından temizleyin.
- Bu akü şarj cihazı ile kullanmak istediğiniz akü kalıcı şekilde bir araca takılı bulunuyorsa, aracın talimat ve/veya bakım kılavuzunun "ELEKTRİK TESİSATI" veya "BAKIM" bölümlerine de danışın. Şarj işlemine başlamadan önce, aracın elektrik tesisatına dahil olan pozitif kablonun ayrılması tavsiye edilir.



إنتبه: اقرأ بعناية دليل الإرشادات قبل استخدام شاحن البطارية!

1. الأمان العام لاستخدام شاحن البطارية هذا



- تصدر عن البطاريات أثناء الشحن غازات متفجرة، فاحذر من التسبب في شرر وألسنة نيران. لا تدخن.
- ضع البطاريات أثناء الشحن في مكان جيد التهوية.



- يجب تدريب الأشخاص الذين ليس لديهم خبرة بشكل ملائم على كيفية استخدام الجهاز.
- يمكن استخدام الجهاز من قبل أطفال أقل من عمر 8 سنوات وكذلك من قبل أشخاص من ذوي القدرات الجسدية والعقلية والحسية المنخفضة أو أولئك الغير متمتعين بالخبرات أو المعرفة الضرورية على أن يكونوا تحت الاشراف أو بعد أن يتلقوا إرشادات تتعلق بالاستخدام الآمن للجهاز واستيعاب الاخطار ذات الصلة.

- لا يجب أن يلعب الاطفال بالجهاز.
- لا يجب القيام بنظافة الجهاز وصيانته من قبل الأطفال دون الإشراف عليهم.
- افصل كابل التغذية بالطاقة عن شبكة الكهرباء قبل توصيل أو فصل كابلات الشاحن من البطارية.

- لا تقم بتوصيل أو فصل الكماشات عن البطارية أثناء تشغيل شاحن البطارية.
- لا تستخدم على الإطلاق شاحن البطارية داخل السيارة أو داخل غطاء محرك السيارة.
- استبدل كابل التغذية بالطاقة فقط بكابل أصلي.

- إذا تلف كابل التغذية بالطاقة فيجب استبداله من قبل الشركة المصنعة أو بواسطة خدمة الدعم الفني التابعة أو على أية حال من قبل أشخاص مؤهلين حتى يتم تحاشي جميع الأخطار.
- لا تستخدم شاحن البطارية لشحن بطاريات غير قابلة للشحن.

- تأكد أن جهد التغذية بالطاقة المتوافق مع الجهد المشار إليه على لوحة بيانات شاحن البطارية.

- لكي لا تتضرر الاجهزة الالكترونية الخاصة بالمركبات يجب القراءة والحفظ والاتباع الدقيق للتحذيرات المقدمة من قبل الشركات المصنعة للمركبات عند استخدام شاحن البطارية سواء في حالة الشحن أو عند بدء التشغيل؛ يعد نفس الامر صالح بالنسبة للإرشادات المقدمة من الشركة المصنعة للبطارية.
- يحتوي هذا الشاحن على أجزاء مثل مفاتيح

التشغيل أو مفاتيح التبادل، والتي يُمكن أن تسبب حدوث شرر أو قوس كهربائي؛ ولذلك عند استخدام شاحن البطارية في الجراج أو في مكان مماثل، ضع شاحن البطارية في مكان أو في علبة مناسبة للغرض.

- يجب أن تتم عمليات الإصلاح والصيانة داخل شاحن البطارية فقط من قبل أفراد ذوي خبرة.

يتم دائماً نزع كابل التغذية بالطاقة من الشبكة الكهربائية قبل القيام بأي إجراء لصيانة شاحن البطاريات.



2. مقدمة ووصف عام

- يسمح شاحن البطارية هذا بشحن بطاريات تعمل بالريصاص ذات الكتروليت حر، والبطاريات محكمة الغلق وبطاريات الليثيوم المستخدمة في مركبات تعمل بمحركات (بنزين، سولار)، دراجات بخارية، مراكب، إلخ.

- مخزونات طاقة قابلة على أساس الجهد الخارج المتاح:

6 فولت، 12 فولت و 24 فولت (وفقاً للوحة البيانات).

- يمكن تغذية شاحن البطاريات هذا، وفقاً لطرازه، الذي يمكن أن يكون بتغذية 230 فوات 50/60 هرتز أو 110 فولت 50/60 هرتز (وفقاً للوحة البيانات) أحادي المرحلة. يتم التحكم بكلاً من تيار وجهد الشحن الصادران عن الجهاز الكترونياً ووفقاً لمنحني الشحن 1A أو U.

- العناصر الاصلية المقدمة:

- يسمح الجهاز بتوصيل أنواع عديدة من الكابلات مع مخارجه لشحن البطاريات:

- كابلات مزودة بثقوب؛

- كابلات مزودة بكماشات.

3. التركيب

وضعية شاحن البطاريات

- ضع شاحن البطارية في وضعية مستقرة خلال تشغيله.

- تجنب رفع شاحن البطارية بواسطة كابل التغذية بالطاقة أو كابل الشحن.

التوصيل بشبكة الطاقة

- يجب توصيل شاحن البطارية حصرياً بنظام تغذية بالطاقة ذو موصل محايد متصل بالأرض.

- تأكد من أن جهد الشبكة يعادل جهد التشغيل.

- يجب أن يكون خط التغذية بالطاقة مزوداً بأنظمة وقائية والتي من بينها الصمامات أو مفاتيح التبادل التلقائية التي تكون كافية لتحمل أقصى حد من إستهلاك الجهاز للطاقة (وفقاً للوحة البيانات).

- يجب أن يتم التوصيل بشبكة الكهرباء بواسطة الكابل المخصص لذلك.

- يجب أن تكون أسلاك الاطالة المحتملة لكابل التغذية بالطاقة ذات فئة ملائمة وألا تقل أبداً عن تلك الخاصة بالكابل المقدم.

4. التشغيل

الإعداد للشحن

لاحظ جيداً: قبل مباشرة الشحن تحقق من أن قدرة البطارية (Ah) التي ينتوى شحنها لا تقل عن تلك القدرة المشار إليها على لوحة المنتج (C min).

قم بتنفيذ التعليمات مع الالتزام التام بالترتيب الوارد أسفله.

- قم بإزالة أغشية البطارية (إن وجدت) حتى تخرج الغازات الناتجة خلال الشحن.
- تحقق من أن مستوى الالكتروليت يغطي شرائح البطارية؛ إذا كانت الشرائح مكشوفة، إذا أضف الماء المقطر حتى تغطيها بحوالي 5 - 10 مم.

تنبيه! يجب الحذر التام خلال

القيام بهذه العملية لأن الالكتروليت

عبارة عن حمض يسبب التآكل



بدرجة عالية للغاية.

- تحقق من أن شاحن البطارية متصل بشبكة الطاقة.
- تحقق من قطبية مشابك البطارية: موجب (رمز +) وسالب (رمز -).
- ملاحظة: إذا لم تكن هناك وسيلة للفرقة بين الرموز تذكر أن المشبك الموجب هو ذلك الغير متصل بهيكل السيارة.
- قم بتوصيل مشبك الشحن ذو اللون الأحمر مع المشبك الموجب للبطارية (رمز +).
- قم بتوصيل مشبك الشحن ذو اللون الأسود بهيكل السيارة بعيداً عن البطارية وبعيداً عن موصل الوقود.
- ملاحظة: إذا لم تكن البطارية غير مثبتة بالسيارة قم بتوصيلها مباشرة مع المشبك السالب للبطارية (الرمز -).

5. نصائح مفيدة

- قم بتنظيف القطبين السالب والموجب من قشور الأكسدة المحتملة بطريقة تسمح بالتوصيل الجيد للمشابك.
- إذا كانت البطارية التي يراد شحنها مثبتة بشكل دائم بالمركبة يجب الرجوع أيضاً إلى الارشادات و/أو دليل صيانة المركبة وهي الارشادات الواردة في بند "النظام الكهربائي" أو "الصيانة". قبل البدء في عملية شحن البطارية يفضل فصل الكابل الموجب الخاص بالنظام الكهربائي للمركبة.

LCD version (page 2)

- Battery charge level.
- Choice of battery type:
 - GEL:** Lead-Calcium (PbCa), solid electrolyte, gel, completely sealed battery. They are maintenance-free batteries.
 - AGM (ABSORBENT GLASS MAT):** lead batteries with electrolyte absorbed in fibreglass. Completely sealed. They are maintenance-free batteries.
 - AGM+:** they ensure a higher number of start-ups at higher current and more in-depth discharge than standard AGM. Used on vehicles with Start-Stop system. Compact dimensions, greater resistance to vibrations and fast recharge times.
 - Lithium (Li):** batteries with reduced weight, high energy density and very low auto-discharge. They are mainly used in the world of motorsport.
 - EFB (Enhanced Flooded Battery):** liquid electrolyte batteries with a higher recharge capacity and which support a higher quantity of cycles (start-ups) than traditional ones. Ideal for vehicles with Start-Stop system.
- Low temperature charge (also indicated for WET batteries).
- Battery voltage set.
- RECOVERY mode.
Additional function, to recover sulphated batteries.
- Generic alarm for polarity reversal, short circuit, worn or faulty battery.
- SUPPLY mode.
Voltage generator SUPPLY mode.
Mode not protected against polarity reversal, short circuit and wrong choice of voltage.
- PULSE-TRONIC charge phases.
- BOOST mode.
Additional function for rapid charge.
- TEST mode.
- Alternator test and Starting Load Efficiency test (CCA).
- Outcome of TEST, RECOVERY and charge end.
- Setting button:
 - PULSE-TRONIC CHARGE (GEL, AGM, AGM +, Li, EFB and low temperatures ❄).
 - TEST (battery status, battery starting load efficiency, vehicle alternator).
 - Advanced Programs: BOOST, RECOVERY, SUPPLY.

LED version (page 2)

- Setting button:
Charge voltage and advanced programs selection.
- Battery voltage set.
- Battery charge level:
Led 25% : charging.
Led 50% : charging.
Led 75% : charging.
Led 100% : fully charged.
- Advanced Programs: **AGM** ❄, **RECOVERY**, **SUPPLY**:
 - **AGM** ❄
The function is useful for charging "AGM" or "WET" type batteries: sealed lead batteries, with electrolyte on absorbent

material, or for charging standard batteries in low temperature conditions below 0°C ❄.

- **RECOVERY**

Additional function, to recover sulphated batteries.

- **SUPPLY**

Voltage generator SUPPLY mode

Mode not protected against polarity reversal, short circuit and wrong choice of voltage.

- Generic alarm for polarity reversal, short circuit, worn or faulty battery.

FUNCTIONS

- PULSE-TRONIC CHARGE
- TEST (where available)
 - CHARGE STATUS TEST
 - BATTERY CRANKING EFFICIENCY TEST (CCA)
 - ALTERNATOR TEST
- BATTERY MAINTENANCE
 - RECOVERY
- POWER SUPPLY
 - SUPPLY (where available)

INFO ALARMS

CHARGER CABLES CONNECTION

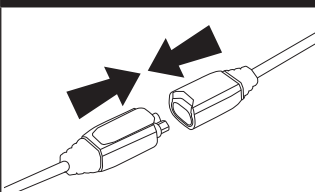

SWITCH ON

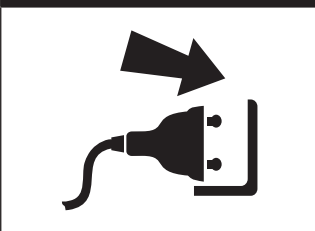

SWITCH OFF

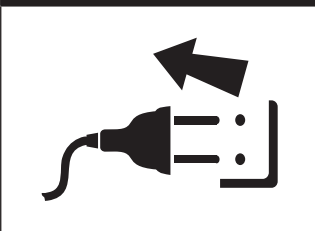

A LOAD/MAINTENANCE

PULSE-TRONIC TECHNOLOGY



1 VOLTAGE SELECTION

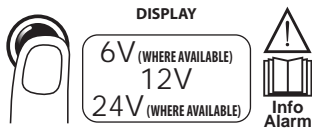

2 PROCESS SELECTION Pulse-Tronic



3 OPTIONAL: ADVANCED MENU SELECTION



Optional for faster charging

4 CLAMPS CONNECTION

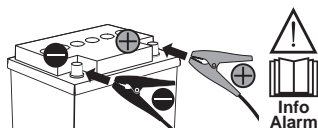

5 PULSE-TRONIC CHARGE PHASES GRAPHIC

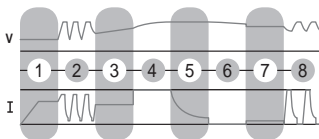

- 1 Battery test
- 2 Pulse recovery of sulphated/very flat batteries
- 3 Integrity control
- 4 Charged up to 80%
- 5 Charged up to 100%
- 6 Charge monitor
- 7 Charge maintenance (*)
- 8 Pulse charge restoration (*)

(*) Maintenance phases after charging has ended.

They are interrupted only on disconnecting the battery charger.

6 CHARGE END - EXAMPLE



Pulse-Tronic charge end - Positive result



Pulse-Tronic charge end - Negative result

B TEST

CHARGE STATUS



1 VOLTAGE SELECTION



DISPLAY

12V



Info Alarm

2 TEST SELECTION



DISPLAY



TEST

3 CLAMPS CONNECTION

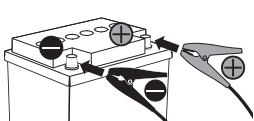

Info Alarm

4 TEST END - EXAMPLE



TEST

12V

DISPLAY LEGEND



very flat



flat



charged

B TEST

BATTERY STARTING LOAD EFFICIENCY



1 VOLTAGE SELECTION



DISPLAY

12V



Info Alarm

2 TEST SELECTION



DISPLAY



TEST

3 CLAMPS CONNECTION

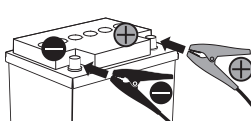

Info Alarm

4 VEHICLE START



5 TEST END - EXAMPLE



TEST

DISPLAY LEGEND



positive



sufficient



negative

B TEST

ALTERNATOR



1 VOLTAGE SELECTION



DISPLAY

12V



2 TEST SELECTION



DISPLAY



TEST

3 CLAMPS CONNECTION

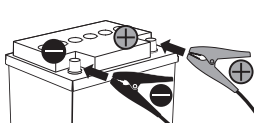

4 VEHICLE START



5 TEST END - EXAMPLE

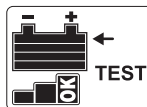

DISPLAY LEGEND



C MAINTENANCE

RECOVERY



1 VOLTAGE SELECTION



DISPLAY

12V



2 ADVANCED MENU SELECTION



DISPLAY



3"

3 CLAMPS CONNECTION

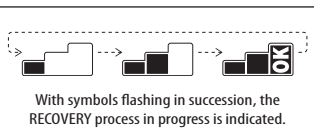
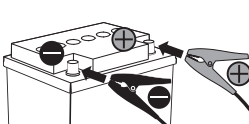

4 PROCESS END - EXAMPLE



5 EXIT FUNCTION



3"

D POWER SUPPLY

SUPPLY SUPPLY

CHANGE BATTERY

1 VOLTAGE SELECTION



DISPLAY

12V



Info Alarm

2 ADVANCED MENU SELECTION



DISPLAY

SUPPLY

3 CLAMPS CONNECTION TO VEHICLE BATTERY CABLES

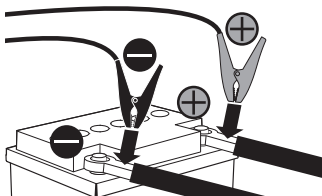

4 VEHICLE POWERED



REMOVAL OF BATTERY



REPLACEMENT OF BATTERY

5 EXIT FUNCTION



3"



INFO ALARMS



Info Alarm



SHORT CIRCUIT

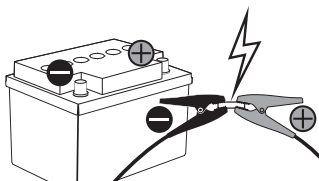

POLARITY REVERSAL

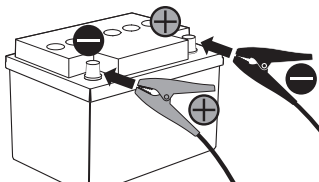

12V

12V

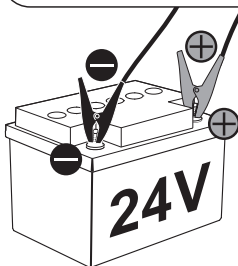

LED version

A CHARGE/ MAINTENANCE

PULSE-TRONIC TECHNOLOGY



1 VOLTAGE SELECTION

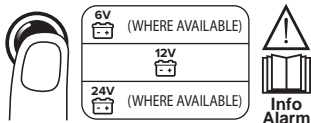

2 OPTIONAL: ADVANCED MENU SELECTION



3 CLAMPS CONNECTION

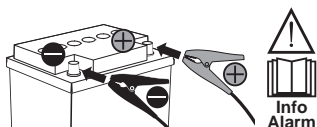

4 CHARGE END - EXAMPLE



Pulse-Tronic charge end - Positive result



Pulse-Tronic charge end - Negative result

C MAINTENANCE

RECOVERY

1 VOLTAGE SELECTION

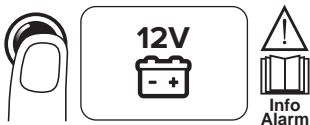

2 ADVANCED MENU SELECTION



3 CLAMPS CONNECTION

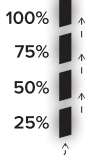
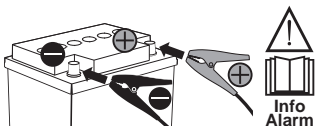

With LEDs flashing in succession, the RECOVERY process in progress is indicated.

4 PROCESS END - EXAMPLE



5 EXIT FUNCTION



D POWER SUPPLY

SUPPLY SUPPLY

CHANGE BATTERY

1 VOLTAGE SELECTION

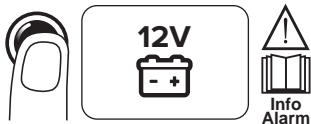

2 ADVANCED MENU SELECTION



3 CLAMPS CONNECTION TO VEHICLE BATTERY CABLES

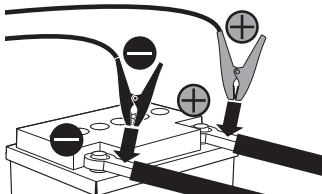

4 VEHICLE POWERED

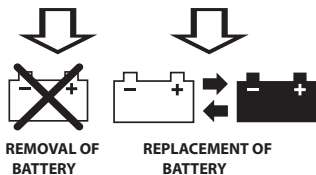

5 EXIT FUNCTION



INFO ALARMS



SHORT CIRCUIT

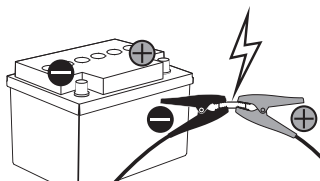

POLARITY REVERSAL

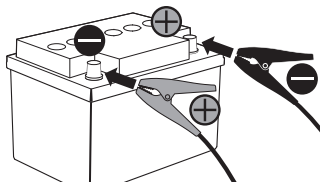

12V

12V



24V

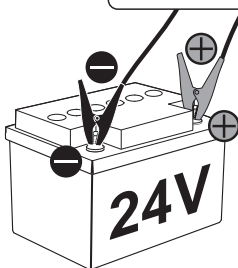

versione LCD (pag. 2)

1. Livello di carica della batteria.
2. Scelta tipologia batteria:
 - **GEL**: batterie al Piombo-Calcio (PbCa) ad elettrolita solido di tipo gelatinoso completamente sigillate. Sono batterie senza manutenzione.
 - **AGM** (ABSORBENT GLASS MAT): batterie al Piombo ad elettrolita assorbito in fibra di vetro. Completamente sigillate. Sono batterie senza manutenzione.
 - **AGM+**: assicurano un numero maggiore di avviamenti ad una corrente superiore ed una più elevata profondità di scarica delle AGM standard. Usate nei veicoli dotati di sistema Start-Stop. Dimensioni ridotte, maggiore resistenza alle vibrazioni e tempi di ricarica veloci.
 - **Litio (Li)**: batterie con peso ridotto, alta densità energetica e bassissima autoscarica. Sono utilizzate principalmente nel mondo del motorsport.
 - **EFB** (Enhanced Flooded Battery): batterie ad elettrolita liquido con una migliore capacità di ricarica e che supportano una quantità di cicli (avviamenti) superiore rispetto a quelle tradizionali. Ideali per veicoli dotati di sistema Start-Stop.
3. Carica a basse temperature (indicata anche per batterie WET).
4. Tensione della batteria impostata.
5. Modalità RECOVERY.
Funzione aggiuntiva per recuperare le batterie solfatate.
6. Allarme generico per inversione polarità, corto circuito, batteria usurata o guasta.
7. Modalità SUPPLY.
Modalità SUPPLY generatore di tensione.
Modalità non protetta da inversione polarità, cortocircuito ed errata scelta tensione.
8. Fasi carica PULSE-TRONIC.
9. Modalità BOOST.
Funzione aggiuntiva per una carica rapida.
10. Modalità TEST.
11. Test alternatore e Test capacità avviamento batteria (CCA).
12. Esito di TEST, RECOVERY e fine carica.
13. Pulsante impostazione:
 - CARICA PULSE-TRONIC (GEL, AGM, AGM+, Li, EFB e basse temperature ❄).
 - TEST (stato batteria, capacità avviamento batteria, alternatore veicolo).
 - Programmi Avanzati: BOOST, RECOVERY, SUPPLY.

versione LED (pag. 2)

1. Pulsante impostazione:
Selezione della tensione di carica e programmi avanzati.
2. Tensione della batteria impostata.
3. Livello di carica della batteria:
 - Led 25%** : carica in corso.
 - Led 50%** : carica in corso.
 - Led 75%** : carica in corso.
 - Led 100%** : fine carica.
4. Programmi Avanzati: **AGM** ❄, **RECOVERY**, **SUPPLY**:
 - **AGM** ❄
Funzione utile per caricare una batteria di tipo "AGM" o "WET": batterie al piombo,

sigillate, con elettrolita su materiale assorbente, oppure, per caricare una batteria generica in condizioni di temperatura basse, sotto 0°C ❄.

• **RECOVERY**

Funzione aggiuntiva per recuperare le batterie solfatate.

• **SUPPLY**

Modalità SUPPLY generatore di tensione
Modalità non protetta da inversione polarità, cortocircuito ed errata scelta tensione.

5. Allarme generico per inversione polarità, corto circuito, batteria usurata o guasta.

FUNZIONI

- A. CARICA PULSE-TRONIC
- B. TEST (ove previsto)
 - TEST STATO DI CARICA
 - TEST CAPACITÀ AVVIAMENTO BATTERIA (CCA)
 - TEST ALTERNATORE
- C. MANUTENZIONE BATTERIE
 - RECOVERY
- D. ALIMENTAZIONE
 - SUPPLY (ove previsto)

INFO ALLARMI

COLLEGAMENTO CAVI DI CARICA

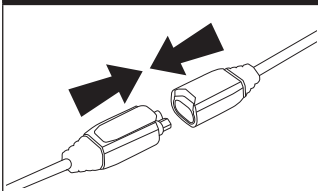

ACCENSIONE

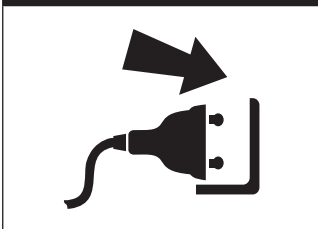

SPEGNIMENTO

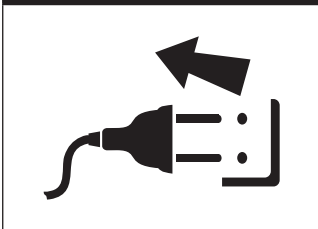

A CARICA/MANTENIMENTO

PULSE-TRONIC TECHNOLOGY



1 SELEZIONE TENSIONE

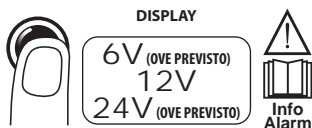

2 SELEZIONE PROCESSO Pulse-Tronic



3 OPZIONALE: SELEZIONE MENU AVANZATO



Opzionale per una carica più veloce

4 COLLEGAMENTO PINZE

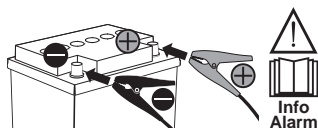

5 GRAFICO FASI DI CARICA PULSE-TRONIC

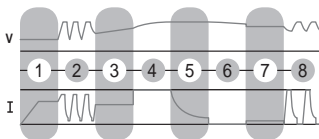

- 1 Test di batteria
- 2 Recupero a impulsi batterie solfatate/ molto scariche
- 3 Controllo integrità
- 4 Carica fino all'80%
- 5 Carica fino al 100%
- 6 Monitor tenuta carica
- 7 Mantenimento carica (*)
- 8 Ripristino carica a impulsi (*)

(*) Fasi di mantenimento dopo la fine della carica.

La loro interruzione avviene dopo aver scollegato il caricabatterie.

6 FINE CARICA - ESEMPIO



Fine carica Pulse-Tronic - Risultato positivo

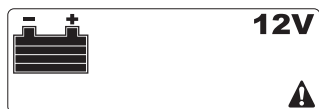

Fine carica Pulse-Tronic - Risultato negativo

B TEST

STATO DI CARICA



1 SELEZIONE TENSIONE



DISPLAY

12V



2 SELEZIONE TEST



DISPLAY



TEST

3 COLLEGAMENTO PINZE

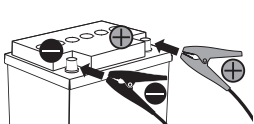

4 FINE TEST - ESEMPIO



TEST

12V

LEGENDA DISPLAY



molto scarica



scarica



carica

B TEST

CAPACITÀ AVVIAMENTO BATTERIA



1 SELEZIONE TENSIONE



DISPLAY

12V



2 SELEZIONE TEST



DISPLAY



TEST

3 COLLEGAMENTO PINZE

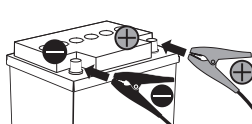

4 AVVIAMENTO VEICOLO



5 FINE TEST - ESEMPIO



TEST



LEGENDA DISPLAY



positivo



sufficiente



negativo

B TEST

ALTERNATORE



1 SELEZIONE TENSIONE



2 SELEZIONE TEST

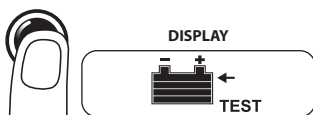

3 COLLEGAMENTO PINZE

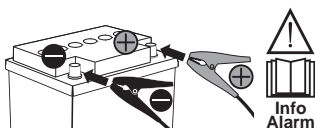

4 AVVIAMENTO VEICOLO



5 FINE TEST - ESEMPIO



LEGENDA DISPLAY



C MANUTENZIONE

RECOVERY



1 SELEZIONE TENSIONE

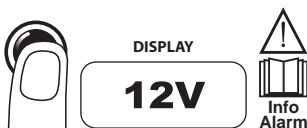

2 SELEZIONE MENU AVANZATO

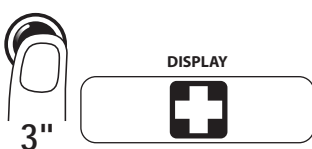

3 COLLEGAMENTO PINZE

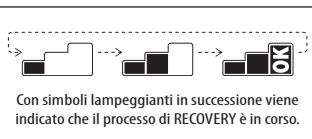
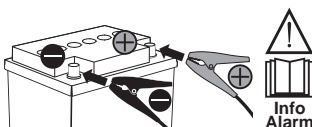

Con simboli lampeggianti in successione viene indicato che il processo di RECOVERY è in corso.

4 FINE PROCESSO - ESEMPIO



5 USCITA DA FUNZIONE



D ALIMENTAZIONE

SUPPLY

SUPPLY

CAMBIO
BATTERIA

1 SELEZIONE TENSIONE



DISPLAY

12V



Info
Alarm

2 SELEZIONE MENU AVANZATO



3"

DISPLAY

SUPPLY

3 COLLEGAMENTO PINZE A CAVI BATTERIA VEICOLO

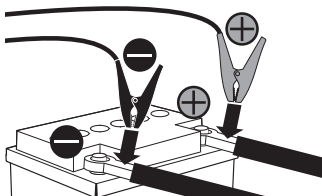

4 VEICOLO ALIMENTATO



RIMOZIONE
BATTERIA



SOSTITUZIONE
BATTERIA

5 USCITA DA FUNZIONE



3"



INFO
ALLARMI



Info
Alarm



CORTO CIRCUITO

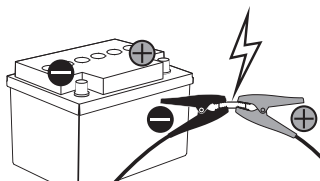

INVERSIONE POLARITÀ

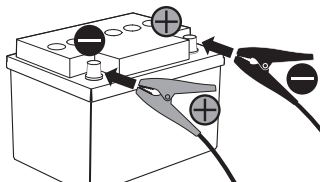

12V

12V

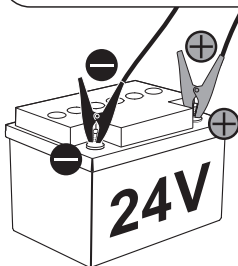

A CARICA/ MANTENIMENTO

PULSE-TRONIC TECHNOLOGY



1 SELEZIONE TENSIONE

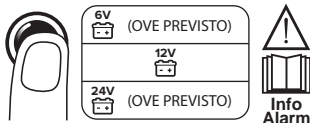

2 OPZIONALE: SELEZIONE MENU AVANZATO



3 COLLEGAMENTO PINZE

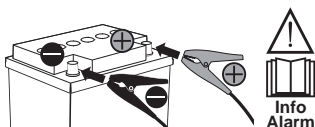

4 FINE CARICA - ESEMPIO



Fine carica Pulse-Tronic - Risultato positivo



Fine carica Pulse-Tronic - Risultato negativo

C MANUTENZIONE

RECOVERY



1 SELEZIONE TENSIONE

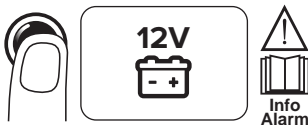

2 SELEZIONE MENU AVANZATO



3 COLLEGAMENTO PINZE

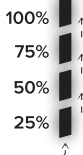
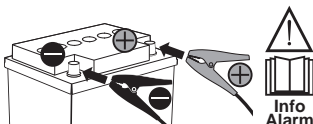

Con led lampeggianti in successione viene indicato che il processo di RECOVERY è in corso.

4 FINE PROCESSO - ESEMPIO



5 USCITA DA FUNZIONE



D ALIMENTAZIONE



INFO ALLARMI



SUPPLY SUPPLY

CAMBIO BATTERIA

1 SELEZIONE TENSIONE



12V



Info Alarm

2 SELEZIONE MENU AVANZATO



3"



SUPPLY

3 COLLEGAMENTO PINZE A CAVI BATTERIA VEICOLO

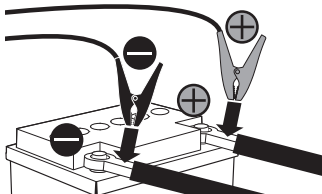

4 VEICOLO ALIMENTATO



RIMOZIONE BATTERIA



SOSTITUZIONE BATTERIA

5 USCITA DA FUNZIONE



3"



CORTO CIRCUITO

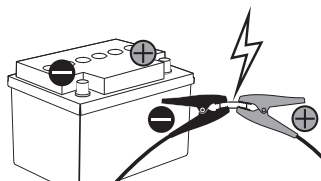

INVERSIONE POLARITÀ

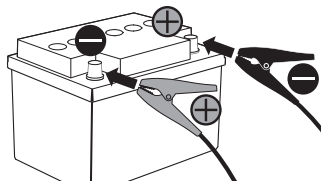

12V

12V



24V

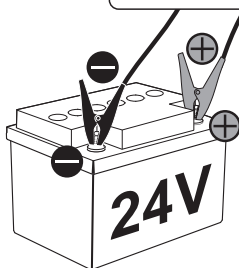

Version LCD (page 2)

- Niveau de charge de la batterie.
- Choix typologie batterie :
 - GEL** : batteries au Plomb-Calcium (PbCa) à électrolyte solide de type gel totalement étanches. Ce sont des batteries qui ne nécessitent pas d'entretien.
 - AGM** (ABSORBENT GLASS MAT) : batteries au Plomb à électrolyte absorbé dans de la fibre de verre. Totalement étanches. Ce sont des batteries qui ne nécessitent pas d'entretien.
 - AGM+** : elles garantissent un nombre supérieur de démarrages à un courant plus élevé et une plus grande profondeur de décharge que les AGM standard. Utilisées sur les véhicules à système Start-Stop. Dimensions réduites, meilleure résistance aux vibrations et temps de recharge courts.
 - Lithium (Li)** : batteries de poids réduit, haute densité énergétique et très faible auto-décharge. Utilisées principalement dans le monde du sport automobile.
 - EFB** (Enhanced Flooded Battery) : batteries à électrolyte liquide avec meilleure capacité de recharge et qui supportent une plus grande quantité de cycles (démarrages) par rapport aux batteries traditionnelles. Idéales pour les véhicules à système Start-Stop.
- Charge à basses températures (indiquée aussi pour batteries WET).
- Tension de la batterie programmée.
- Modalité RECOVERY.
Fonction supplémentaire, pour récupérer les batteries sulfatées.
- Alarme générique pour inversion de polarité, court-circuit, batterie usagée ou défectueuse.
- Modalité SUPPLY.
Modalité SUPPLY générateur de tension.
Mode non protégée contre l'inversion de polarité, les court-circuits et les erreurs de choix de tension.
- Phases de la charge PULSE-TRONIC.
- Mode BOOST.
Fonction supplémentaire pour une charge rapide.
- Mode TEST.
- Test alternateur et test de capacité de démarrage batterie (CCA).
- Résultat TEST, RECOVERY et fin de charge.
- Bouton programmation :
 - CHARGE PULSE-TRONIC (GEL, AGM, AGM+, Li, EFB et basses températures ❄).
 - TEST (état batterie, capacité de démarrage batterie, alternateur véhicule).
 - Programmes avancés : BOOST, RECOVERY, SUPPLY.

Version LED (page 2)

- Bouton programmation :
Sélection de la tension de charge et programmes avancés.
- Tension de la batterie programmée.
- Niveau de charge de la batterie :
LED 25% : charge en cours.
LED 50% : charge en cours.
LED 75% : charge en cours.
LED 100% : charge terminée.

- Programmes avancés : **AGM** ❄
RECOVERY, SUPPLY :
 - **AGM** ❄
Fonction utile pour charger une batterie de type « **AGM** » ou « **WET** » : batteries au plomb, scellées, avec électrolyte sur matériau absorbant, ou pour charger une batterie générique en conditions de basse température, inférieure à 0°C ❄.
 - **RECOVERY**
Fonction supplémentaire, pour récupérer les batteries sulfatées.
 - **SUPPLY**
Mode SUPPLY générateur de tension
Mode non protégée contre l'inversion de polarité, les court-circuits et les erreurs de choix de tension.
- Alarme générique pour inversion de polarité, court-circuit, batterie usagée ou défectueuse.

FONCTIONS

- CHARGE PULSE-TRONIC
- TEST (lorsque prévu)
 - TEST ÉTAT DE CHARGE
 - TEST CAPACITÉ DÉMARRAGE BATTERIE (CCA)
 - TEST ALTERNATEUR
- ENTRETIEN BATTERIES
 - RECOVERY
- ALIMENTATION
 - SUPPLY (lorsque prévu)

INFOS ALARMES

BRANCHEMENT CÂBLES DE CHARGEMENT

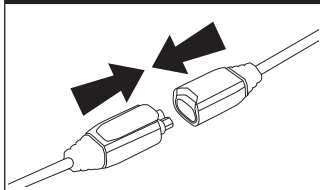

ALLUMAGE

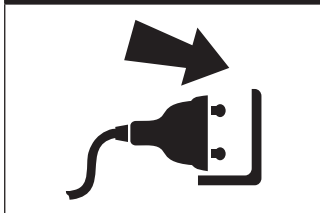

EXTINCTION

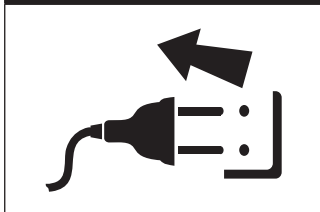

A CHARGE/MAINTIEN

PULSE-TRONIC TECHNOLOGY



1 SÉLECTION TENSION

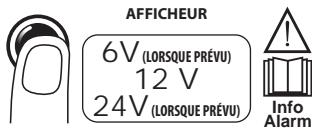

2 SÉLECTION PROCÉDÉ Pulse-Tronic



3 EN OPTION : SÉLECTION MENU AVANCÉ



Option pour une charge plus rapide

4 BRANCHEMENT PINCES

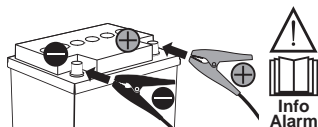

5 GRAPHIQUE PHASES DE CHARGE PULSE-TRONIC

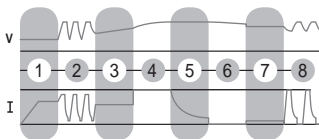

- 1 Test de batterie
- 2 Récupération batteries sulfatées / très déchargées
- 3 Contrôle intégrité
- 4 Chargée jusqu'à 80 %
- 5 Chargée jusqu'à 100 %
- 6 Dispositif de contrôle étanchéité charge
- 7 Maintien charge (*)
- 8 Rétablissement de la charge par impulsions (*)

(*) Phases de maintien une fois la charge terminée.

Leur interruption survient après avoir débranché le chargeur.

6 FIN DE CHARGE - EXEMPLE

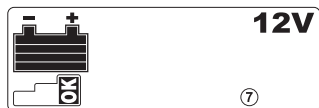

Fin de charge Pulse-Tronic - Résultat positif

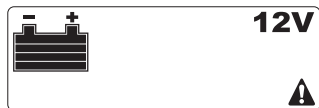

Fin de charge Pulse-Tronic - Résultat négatif

B TEST

ÉTAT DE CHARGE



1 SÉLECTION TENSION



AFFICHEUR

12V



Info Alarm

2 SÉLECTION TEST



AFFICHEUR



TEST

3 BRANCHEMENT PINCES

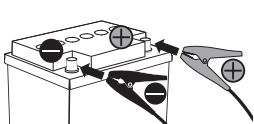

Info Alarm

4 FIN TEST - EXEMPLE



TEST

12V

LÉGENDE AFFICHEUR



très déchargée



déchargée



chargée

B TEST

CAPACITÉ DÉMARRAGE
BATTERIE



1 SÉLECTION TENSION



AFFICHEUR

12V



Info Alarm

2 SÉLECTION TEST



AFFICHEUR



TEST

3 BRANCHEMENT PINCES

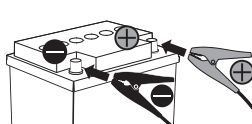

Info Alarm

4 DÉMARRAGE VÉHICULE



5 FIN TEST - EXEMPLE



TEST

OK

LÉGENDE AFFICHEUR



positif



suffisant



négatif

B TEST

ALTERNATEUR



1 SÉLECTION TENSION



AFFICHEUR

12V



2 SÉLECTION TEST



AFFICHEUR



TEST

3 BRANCHEMENT PINCES

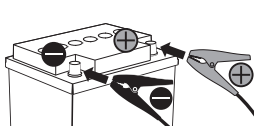

4 DÉMARRAGE VÉHICULE



5 FIN TEST - EXEMPLE

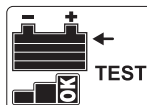

LÉGENDE AFFICHEUR



positif



suffisant



négatif

C ENTRETIEN

RECOVERY



1 SÉLECTION TENSION



AFFICHEUR

12V



2 SÉLECTION MENU AVANCÉ



AFFICHEUR



3"

3 BRANCHEMENT PINCES

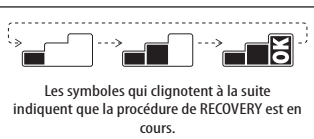
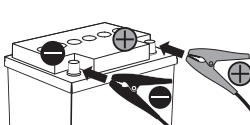

Les symboles qui clignotent à la suite indiquent que la procédure de RECOVERY est en cours.

4 FIN PROCESS - EXEMPLE



5 SORTIE DE LA FONCTION



3"

D ALIMENTATION

SUPPLY SUPPLY

CHANGEMENT BATTERIE

1 SÉLECTION TENSION



AFFICHEUR

12V



Info Alarm

2 SÉLECTION MENU AVANCÉ



AFFICHEUR

SUPPLY

3 BRANCHEMENT PINCES À CÂBLES BATTERIE VÉHICULE

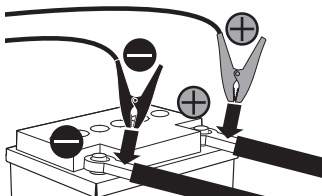

4 VÉHICULE ALIMENTÉ



RETRAIT BATTERIE



REMPACEMENT BATTERIE

5 SORTIE DE LA FONCTION



3''



INFOS ALARMES



Info Alarm



COURT-CIRCUIT

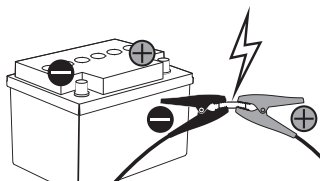

INVERSION DE POLARITÉ

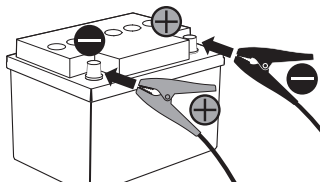

12V

12V

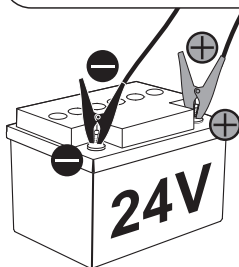

Version LED

A

CHARGE/ MAINTIEN

PULSE-TRONIC TECHNOLOGY



1 SÉLECTION TENSION

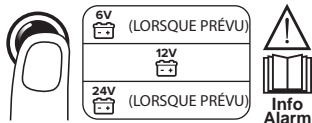

2 EN OPTION : SÉLECTION MENU AVANCÉ



3 BRANCHEMENT PINCES

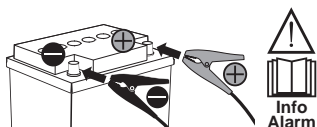

4 FIN DE CHARGE - EXEMPLE



Fin de charge Pulse-Tronic - Résultat positif



Fin de charge Pulse-Tronic - Résultat négatif

C

ENTRETIEN

RECOVERY



1 SÉLECTION TENSION

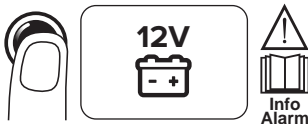

2 SÉLECTION MENU AVANCÉ



3 BRANCHEMENT PINCES

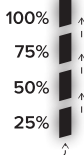
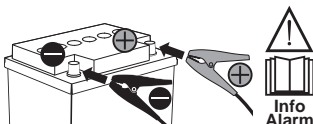

Les LED qui clignotent à la suite indiquent que la procédure de RECOVERY est en cours.

4 FIN PROCESS - EXEMPLE



5 SORTIE DE LA FONCTION



D ALIMENTATION

SUPPLY SUPPLY

CHANGEMENT BATTERIE

1 SÉLECTION TENSION

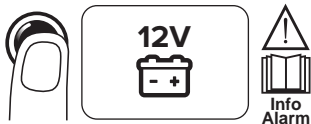

2 SÉLECTION MENU AVANCÉ



3 BRANCHEMENT PINCES À CÂBLES BATTERIE VÉHICULE

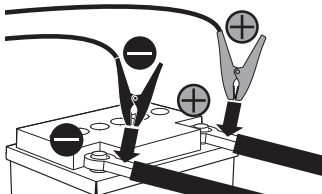

4 VÉHICULE ALIMENTÉ

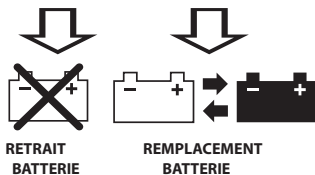

5 SORTIE DE LA FONCTION



INFOS ALARMES



Info Alarm



COURT-CIRCUIT

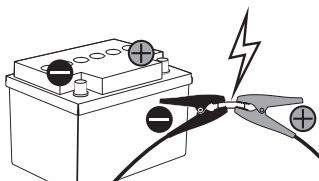

INVERSION DE POLARITÉ

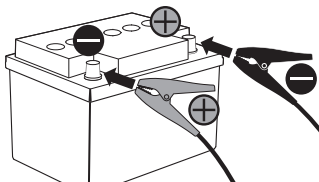

12V

12V



24V

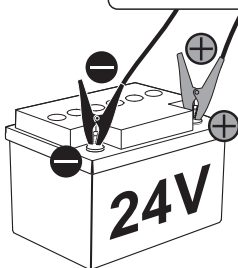

Versión LCD (pág. 2)

1. Nivel de carga de la batería.
2. Elección del tipo de batería:
 - **GEL:** baterías al plomo-calcio (PbCa) de electrolito sólido de tipo gelatinoso completamente selladas. Son baterías sin mantenimiento.
 - **AGM (ABSORBENT GLASS MAT):** baterías al plomo con electrolito absorbido en fibra de vidrio. Completamente selladas. Son baterías sin mantenimiento.
 - **AGM+:** aseguran un mayor número de arranques con una corriente superior y una profundidad de descarga más elevada que las AGM estándar. Se usan en los vehículos dotados de sistema Start-Stop. Dimensiones reducidas, mayor resistencia a las vibraciones y tiempos de recarga rápidos.
 - **Litio (Li):** baterías con un peso reducido, alta densidad de energía y bajísima autodescarga. Se utilizan sobre todo en el mundo del automovilismo.
 - **EFB (Enhanced Flooded Battery):** baterías de electrolito líquido con una mejor capacidad de recarga y que admiten una cantidad de ciclos (arranques) superior respecto a las tradicionales. Ideales para los vehículos dotados de sistema Start-Stop.
3. Carga a temperaturas bajas (indicada también para baterías WET).
4. Tensión de la batería configurada.
5. Modalidad RECOVERY.
Función adicional para recuperar las baterías sulfatadas.
6. Alarma genérica por inversión de polaridad, cortocircuito, batería gastada o averiada.
7. Modalidad SUPPLY.
Modalidad SUPPLY generador de tensión.
Modalidad no protegida por inversión de polaridad, cortocircuito o mala elección de tensión.
8. Fases de carga PULSE-TRONIC.
9. Modalidad BOOST.
Función adicional para una carga rápida.
10. Modalidad TEST.
11. Test alternador y Test capacidad arranque batería (CCA).
12. Resultado de TEST, RECOVERY y final de carga.
13. Pulsador configuración:
 - CARGA PULSE-TRONIC (GEL, AGM, AGM+, Li, EFB y bajas temperaturas ❄).
 - TEST (estado de batería, capacidad de arranque de batería, alternador vehículo).
 - Programas avanzados: BOOST, RECOVERY, SUPPLY.

Versión LED (pág. 2)

1. Pulsador configuración:
Selección de la tensión de carga y programas avanzados.
2. Tensión de la batería configurada.
3. Nivel de carga de la batería:
 - Led 25% :** carga en curso.
 - Led 50% :** carga en curso.
 - Led 75% :** carga en curso.
 - Led 100% :** final de carga.
4. Programas avanzados: **AGM** ❄
RECOVERY, SUPPLY:
 - **AGM** ❄

Función útil para cargar una batería de tipo "AGM" o "WET": baterías al plomo, selladas, con electrolito en material absorbente, o para cargar una batería genérica en condiciones de temperaturas bajas, por debajo de 0°C ❄.

- **RECOVERY**
Función adicional para recuperar las baterías sulfatadas.
 - **SUPPLY**
Modalidad SUPPLY generador de tensión
Modalidad no protegida por inversión de polaridad, cortocircuito o mala elección de tensión.
5. Alarma genérica por inversión de polaridad, cortocircuito, batería gastada o averiada.

FUNCIONES

- A. CARGA PULSE-TRONIC
- B. TEST (si se ha previsto)
 - TEST ESTADO DE CARGA
 - TEST DE CAPACIDAD DE ARRANQUE BATERÍA (CCA)
 - TEST DEL ALTERNADOR
- C. MANTENIMIENTO BATERÍAS
 - RECOVERY
- D. ALIMENTACIÓN
 - SUPPLY (si se ha previsto)

INFO ALARMAS

CONEXIÓN CABLES DE CARGA

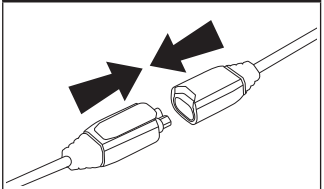

ENCENDIDO

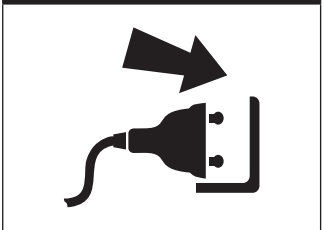

APAGADO

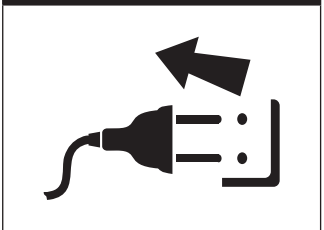

A CARGA/MANTENIMIENTO

PULSE-TRONIC TECHNOLOGY



1 SELECCIÓN TENSIÓN

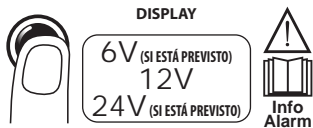

2 SELECCIÓN PROCESO Pulse-Tronic



3 OPCIONAL: SELECCIÓN MENÚ AVANZADO



Opcional para carga más rápida

4 CONEXIÓN PINZAS

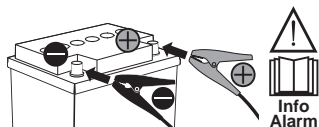

5 GRÁFICO FASES DE CARGA PULSE-TRONIC

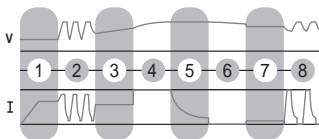

- 1 Test de batería
- 2 Recuperación por impulsos baterías sulfatadas / muy descargadas
- 3 Control integridad
- 4 Carga hasta el 80%
- 5 Carga hasta el 100%
- 6 Monitor estanqueidad carga
- 7 Mantenimiento carga (*)
- 8 Restablecimiento carga por impulsos (*)

(*) Fases de mantenimiento después del fin de la carga.

La interrupción se produce después de haber desconectado el cargador de baterías.

6 FIN CARGA - EJEMPLO



Fin carga Pulse-Tronic - Resultado positivo



Fin carga Pulse-Tronic - Resultado negativo

B TEST

ESTADO DE CARGA



1 SELECCIÓN TENSIÓN



DISPLAY

12V



Info Alarm

2 SELECCIÓN TEST



DISPLAY



TEST

3 CONEXIÓN PINZAS

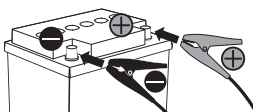

Info Alarm

4 FIN TEST - EJEMPLO



TEST

12V

LEYENDA DISPLAY



muy descargada



descargada



cargada

B TEST

CAPACIDAD ARRANQUE BATERÍA



1 SELECCIÓN TENSIÓN



DISPLAY

12V



Info Alarm

2 SELECCIÓN TEST



DISPLAY



TEST

3 CONEXIÓN PINZAS

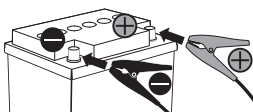

Info Alarm

4 ARRANQUE VEHÍCULO



5 FIN TEST - EJEMPLO



TEST

OK

LEYENDA DISPLAY



positivo



suficiente



negativo

B TEST

ALTERNADOR



1 SELECCIÓN TENSIÓN



DISPLAY

12V



Info Alarm

2 SELECCIÓN TEST



DISPLAY



TEST

3 CONEXIÓN PINZAS

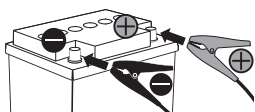

Info Alarm

4 ARRANQUE VEHÍCULO



5 FIN TEST - EJEMPLO

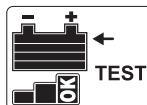

TEST

LEYENDA DISPLAY



positivo



suficiente



negativo

C MANTENIMIENTO

RECOVERY



1 SELECCIÓN TENSIÓN



DISPLAY

12V



Info Alarm

2 SELECCIÓN MENÚ AVANZADO



DISPLAY



3"

3 CONEXIÓN PINZAS

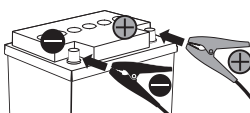

Info Alarm

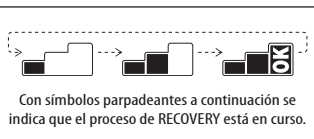

Con símbolos parpadeantes a continuación se indica que el proceso de RECOVERY está en curso.

4 FIN PROCESO - EJEMPLO



12V



5 SALIDA DE FUNCIÓN



3"

D ALIMENTACIÓN

SUPPLY SUPPLY

CAMBIO BATERÍA

1 SELECCIÓN TENSIÓN



DISPLAY

12V



Info Alarm

2 SELECCIÓN MENÚ AVANZADO



DISPLAY

SUPPLY

3"

3 CONEXIÓN PINZAS A CABLES BATERÍA VEHÍCULO

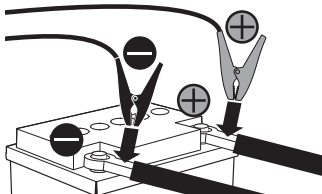

4 VEHÍCULO ALIMENTADO

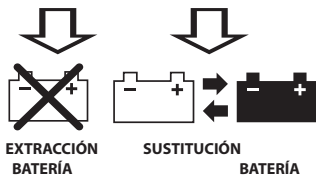

EXTRACCIÓN BATERÍA

SUSTITUCIÓN

BATERÍA

5 SALIDA DE FUNCIÓN



3"



INFO ALARMAS



Info Alarm



CORTO CIRCUITO

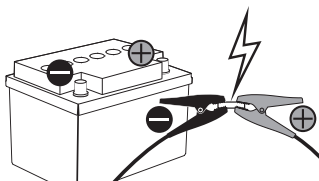

INVERSIÓN POLARIDAD

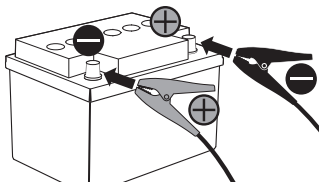

12V

12V

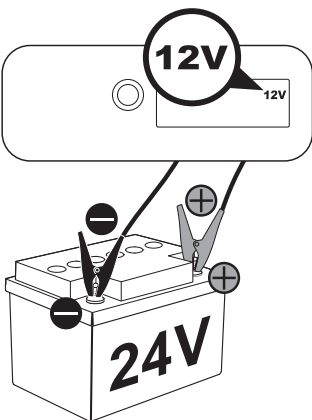

Versión LED

A CARGA/ MANTENIMIENTO

PULSE-TRONIC TECHNOLOGY



1 SELECCIÓN TENSIÓN

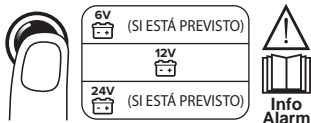

2 OPCIONAL: SELECCIÓN MENÚ AVANZADO



3 CONEXIÓN PINZAS

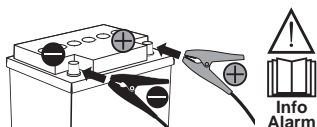

4 FIN CARGA - EJEMPLO



Fin carga Pulse-Tronic - Resultado positivo



Fin carga Pulse-Tronic - Resultado negativo

C MANTENIMIENTO

RECOVERY



1 SELECCIÓN TENSIÓN

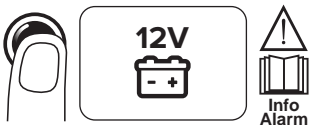

2 SELECCIÓN MENÚ AVANZADO



3 CONEXIÓN PINZAS

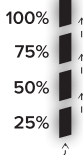
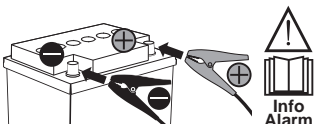

Con led parpadeantes a continuación se indica que el proceso de RECOVERY está en curso.

4 FIN PROCESO - EJEMPLO



5 SALIDA DE FUNCIÓN



D ALIMENTACIÓN

SUPPLY

SUPPLY

CAMBIO BATERÍA

1 SELECCIÓN TENSIÓN



12V



Info Alarm

2 SELECCIÓN MENÚ AVANZADO



3"



SUPPLY

3 CONEXIÓN PINZAS A CABLES BATERÍA VEHÍCULO

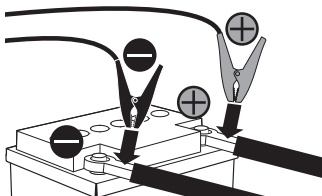

4 VEHÍCULO ALIMENTADO



EXTRACCIÓN BATERÍA



SUSTITUCIÓN BATERÍA

5 SALIDA DE FUNCIÓN



3"



INFO ALARMAS



Info Alarm



CORTO CIRCUITO

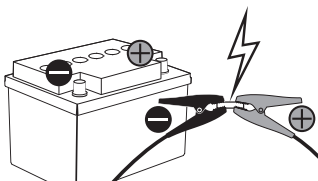

INVERSIÓN POLARIDAD

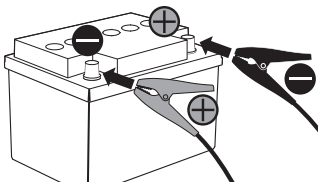

12V

12V



24V

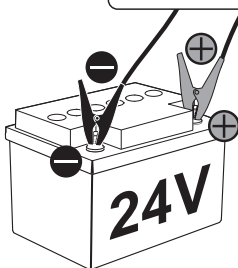

LCD-Version (S. 2)

- Ladestand der Batterie.
- Einstellung Batterietyp:
 - GEL:** Blei-Calcium-Batterien (PbCa) mit festem, gelatineartigem Elektrolyt, komplett verschlossen. Die Batterien sind wartungsfrei.
 - AGM (ABSORBENT GLASS MAT):** Bleibatterien mit in Glasfaser gebundenem Elektrolyt. Vollständig verschlossen. Die Batterien sind wartungsfrei.
 - AGM+:** eine höhere Anzahl an Startvorgängen bei höherem Stromwert und einer höheren Entladungstiefe als bei den AGM-Standardbatterien wird sichergestellt. Sie werden in Fahrzeugen mit Start-Stopp-System verwendet. Kompakt sowie widerstandsfähiger gegenüber Vibrationen und schnelle Ladezeiten.
 - Lithium (Li):** gewichtsreduzierte Batterien mit hoher Energiedichte und sehr niedriger Selbstentladung. Sie finden hauptsächlich in der Welt des Motorsports Anwendung.
 - EFB (Enhanced Flooded Battery):** Batterien mit Flüssigelektrolyt mit einer besseren Ladekapazität und der Möglichkeit, mehr Ladezyklen (Startvorgänge) im Vergleich zu herkömmlichen Batterien durchzuführen. Sie eignen sich ideal für den Einsatz in Fahrzeugen mit Start-Stopp-System.
- Laden bei niedrigen Temperaturen (auch für WET-Batterien geeignet).
- Eingestellte Batteriespannung.
- Modus RECOVERY.
Zusatzfunktion zur Instandsetzung sulfatierter Batterien.
- Allgemeiner Alarm wegen Verpolung, Kurzschluss, verbrauchter oder schadhafter Batterie.
- Modus SUPPLY.
Modus SUPPLY Spannungserzeuger.
Ungeschützter Modus vor Verpolung, Kurzschluss und falscher Spannungswahl.
- Ladephase PULSE-TRONIC.
- Modus BOOST.
Zusatzfunktion für die Schnellaufladung.
- Modus TEST.
- Test Drehstromgenerator und Test Startleistung Batterie (CCA).
- Ergebnis von TEST, RECOVERY und Ende Ladevorgang.
- Knopf für die Einstellung:
 - LADEVORGANG PULSE-TRONIC (GEL, AGM, AGM +, Li, EFB und niedrige Temperaturen ❄).
 - TEST (Batteriezustand, Startleistung Batterie, Fahrzeugdrehstromgenerator).
 - Erweiterte Programme: BOOST, RECOVERY, SUPPLY.

LED-Version (S. 2)

- Knopf für die Einstellung:
Auswahl der Ladespannung und der erweiterten Programme.
- Eingestellte Batteriespannung.
- Ladestand der Batterie:
LED 25% : Ladevorgang läuft.
LED 50% : Ladevorgang läuft.
LED 75% : Ladevorgang läuft.

- LED 100% :** Ladevorgang beendet.
- Erweiterte Programme: **AGM** ❄
RECOVERY, SUPPLY:
 - AGM** ❄
Nützliche Funktion zum Laden einer Batterie vom Typ „AGM“ oder „WET“: Bleibatterien, verschlossene Batterien, Batterien mit Elektrolyt auf absorbierendem Material oder zum Laden einer gängigen Batterie bei Minusgraden ❄.
 - RECOVERY**
Zusatzfunktion zur Instandsetzung sulfatierter Batterien.
 - SUPPLY**
Modus SUPPLY Spannungserzeuger
Ungeschützter Modus vor Verpolung, Kurzschluss und falscher Spannungswahl.
 - Allgemeiner Alarm wegen Verpolung, Kurzschluss, verbrauchter oder geschädigter Batterie.

FUNKTIONEN

- LADEVORGANG PULSE-TRONIC
- TEST (wo dies vorgesehen ist)
 - TEST LADEZUSTAND
 - TEST STARTLEISTUNG BATTERIE (CCA)
 - TEST DREHSTROMGENERATOR
- BATTERIEWARTUNG
 - RECOVERY
- SPANNUNGSVERSORGUNG
 - SUPPLY (wo dies vorgesehen ist)

ALARMINFORMATIONEN

VERBINDUNG LADEKABEL

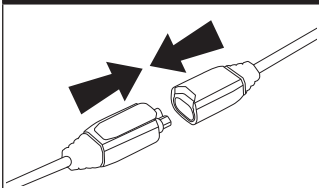

EINSCHALTEN

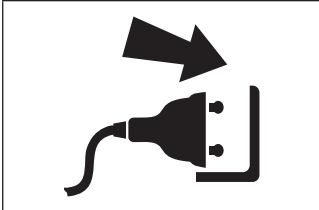

AUSSCHALTEN

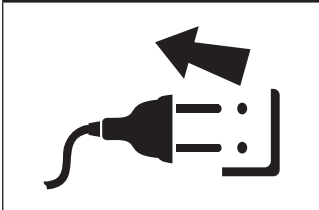

A LADEN/ERHALTUNGSLADEN

PULSE-TRONIC TECHNOLOGY



1 SPANNUNGS-AUSWAHL

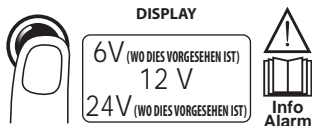

2 AUSWAHL VERFAHREN Pulse-Tronic



3 OPTIONAL: AUSWAHL ERWEITERTES MENÜ



Optional für ein schnelleres Laden

4 ANSCHLUSS ZANGEN

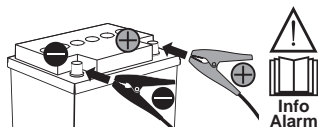

5 GRAFIK LADEPHASEN PULSE-TRONIC

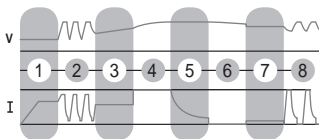

- 1 Batterietest
- 2 Instandsetzung mit Impulsen sulfatierter/stark entladener Batterien
- 3 Prüfung auf einwandfreien Zustand
- 4 Aufladen auf 80%
- 5 Aufladen auf 100%
- 6 Überwachung Ladungserhaltung
- 7 Erhaltungsladen (*)
- 8 Impulsweises Nachladen (*)

(*) Phasen des Erhaltungsladens nach dem Laden.

Die Unterbrechung der Phasen erfolgt nach getrenntem Ladegerät.

6 ENDE LADEVORGANG - BEISPIEL



Ende Ladevorgang Pulse-Tronic - positiv



Ende Ladevorgang Pulse-Tronic - negativ

B TEST

LADEZUSTAND



1 SPANNUNGS-AUSWAHL



2 TEST-AUSWAHL

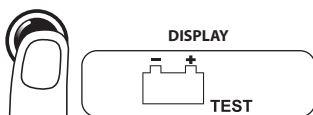

3 ANSCHLUSS ZANGEN

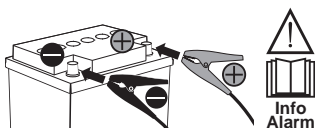

4 ENDE TEST - BEISPIEL



ZEICHENERKLÄRUNG DISPLAY

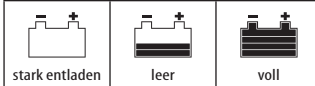

B TEST

STARTLEISTUNG BATTERIE



1 SPANNUNGS-AUSWAHL



2 TEST-AUSWAHL

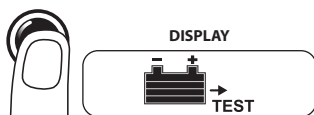

3 ANSCHLUSS ZANGEN

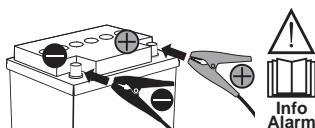

4 FAHRZEUGSTART



5 ENDE TEST - BEISPIEL



ZEICHENERKLÄRUNG DISPLAY



B TEST

DREHSTROMGENERATOR 

1 SPANNUNGS-AUSWAHL

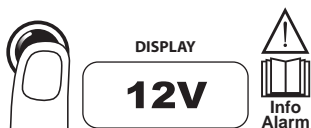

2 TEST-AUSWAHL

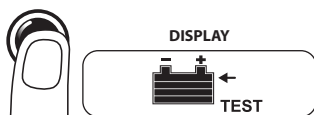

3 ANSCHLUSS ZANGEN

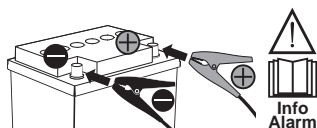

4 FAHRZEUGSTART



5 ENDE TEST - BEISPIEL

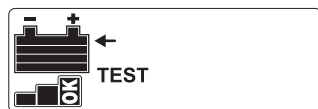

ZEICHENERKLÄRUNG DISPLAY



C WARTUNG

RECOVERY 

1 SPANNUNGS-AUSWAHL

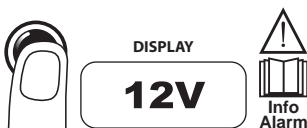

2 AUSWAHL ERWEITERTES MENÜ

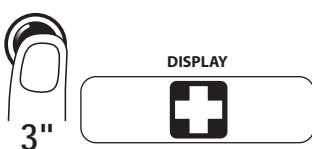

3 ANSCHLUSS ZANGEN

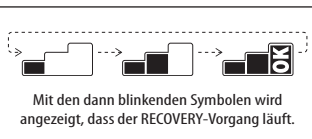
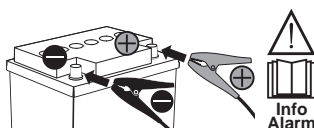

4 ENDE VORGANG - BEISPIEL



5 FUNKTION VERLASSEN



D**SPANNUNGSVERSORGUNG****ALARMINFORMATIONEN**Info
Alarm**SUPPLY**

SUPPLY

**WECHSEL
BATTERIE****1 SPANNUNGSWAHL**

DISPLAY

12VInfo
Alarm**2 AUSWAHL ERWEITERTES
MENÜ**

DISPLAY

SUPPLY

3"

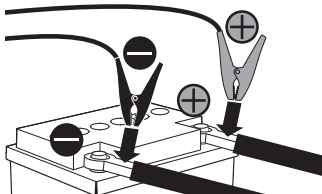
**3 ANSCHLUSS ZANGEN AN
FAHRZEUGBATTERIEKABELN****4 MIT STROM VERSORGTES FAHRZEUG**BATTERIE
ENTFERNENBATTERIE
AUSTAUSCHEN**5 FUNKTION VERLASSEN**

3"

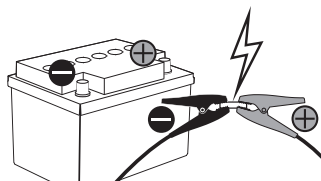
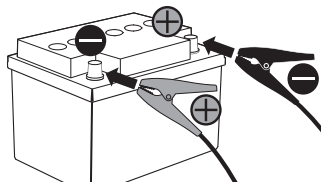
**KURZSCHLUSS****VERPOLUNG****12V**

12V

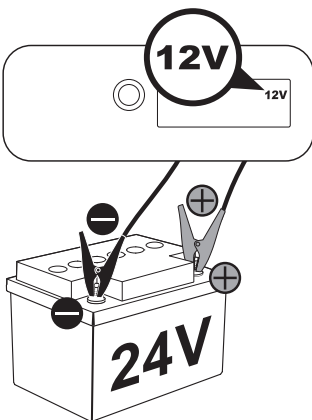

LED-Version

A LADEN/ ERHALTUNGSLADEN

PULSE-TRONIC TECHNOLOGY



1 SPANNUNGS-AUSWAHL

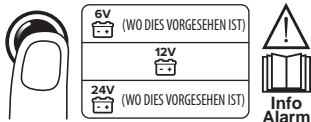

2 OPTIONAL: AUSWAHL ERWEITERTES MENÜ



3 ANSCHLUSS ZANGEN

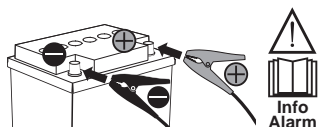

4 ENDE LADEVORGANG - BEISPIEL



Ende Ladevorgang Pulse-Tronic - positiv



Ende Ladevorgang Pulse-Tronic - negativ

C WARTUNG

RECOVERY

1 SPANNUNGS-AUSWAHL

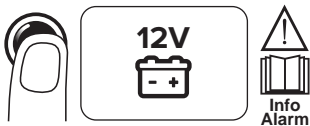

2 AUSWAHL ERWEITERTES MENÜ



3 ANSCHLUSS ZANGEN

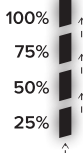
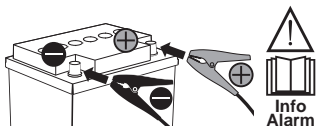

Mit den dann blinkenden LEDs wird angezeigt, dass der RECOVERY-Vorgang läuft.

4 ENDE VORGANG - BEISPIEL



5 FUNKTION VERLASSEN



D SPANNUNGSVERSORGUNG



ALARMINFORMATIONEN Info Alarm

SUPPLY SUPPLY

WECHSEL
BATTERIE

1 SPANNUNGSWAHL



Info Alarm

2 AUSWAHL ERWEITERTES MENÜ



3"

3 ANSCHLUSS ZANGEN AN FAHRZEUGBATTERIEKABELN

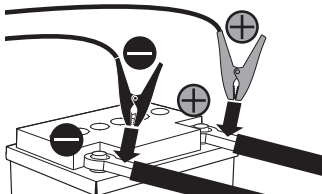

4 MIT STROM VERSORGTES FAHRZEUG



BATTERIE
ENTFERNEN

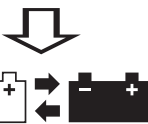

BATTERIE
AUSTAUSCHEN

5 FUNKTION VERLASSEN



3"



KURZSCHLUSS

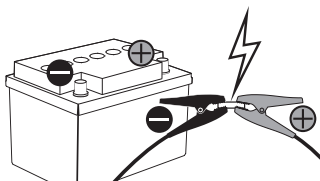

VERPOLUNG

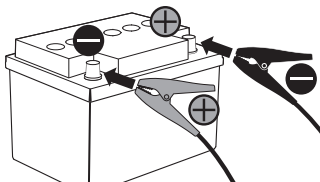

12V

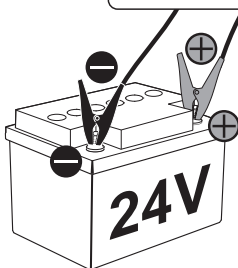

24V

Версия с ЖК-дисплеем (стр. 2)

1. Уровень заряда аккумулятора.
2. Выбор типа аккумулятора:
 - **GEL:** полностью герметичные свинцово-кальциевые (PbCa) аккумуляторы с твердым желеобразным электролитом. Эти аккумуляторы не требуют обслуживания.
 - **AGM (ABSORBENT GLASS MAT – с поглощающим стекловолокном):** свинцовые аккумуляторы с пропитанным электролитом стекловолокном. Полностью герметичные. Эти аккумуляторы не требуют обслуживания.
 - **AGM+:** обеспечивают большее количество пусков при более высоком токе и большую глубину разряда, чем стандартные аккумуляторы AGM. Используется в автомобилях, оборудованных системой «Старт-Стоп». Небольшой размер, повышенная устойчивость к вибрациям и быстрая зарядка.
 - **Литиевые (Li):** аккумуляторы, отличающиеся малым весом, высокой плотностью энергии и очень низким саморазрядом. В основном они используются в мире автоспорта.
 - **Аккумуляторы EFB (Enhanced Flooded Battery – улучшенный залитый аккумулятор):** аккумуляторы с жидким электролитом с лучшей способностью к подзарядке, которые обеспечивают большее количество циклов (пусков), чем традиционные аккумуляторы. Идеально подходят для автомобилей, оборудованных системой «Старт-Стоп».
3. Зарядка при низкой температуре (подходит также для аккумуляторов WET).
4. Напряжение аккумулятора установлено.
5. Режим ВОССТАНОВЛЕНИЕ.

Дополнительная функция которая позволяет восстановить сульфатированные аккумуляторы.
6. Общий сигнал тревоги из-за нарушения полярности, короткого замыкания, износившегося или поврежденного аккумулятора.
7. Режим SUPPLY.

Режим SUPPLY генератора напряжения. **Режим не защищен от неправильной полярности, короткого замыкания и неправильно выбранного напряжения.**
8. Фазы зарядки PULSE-TRONIC.
9. Режим BOOST.

Дополнительная функция для быстрой зарядки.
10. Режим TEST.
11. Проверка генератора и проверка пусковой способности аккумулятора (CCA).
12. Результат ПРОВЕРКИ, RECOVERY (восстановление) и завершение зарядки.
13. Кнопка настройки:
 - ЗАРЯДКА PULSE-TRONIC (GEL, AGM, AGM +, Li, EFB и при низкой температуре ❄).
 - ПРОВЕРКА (состояние аккумулятора, пусковая способность аккумулятора, генератор транспортного средства).
 - Расширенные программы: BOOST, RECOVERY, SUPPLY.

Светодиодная версия (стр. 2)

1. Кнопка настройки:

Выбор напряжения зарядки и расширенные программы.
2. Напряжение аккумулятора установлено.
3. Уровень заряда аккумулятора:

Светодиод 25%: идет зарядка.
Светодиод 50%: идет зарядка.
Светодиод 75%: идет зарядка.

Светодиод 100%: окончание зарядки.

4. Расширенные программы: **AGM ❄**, **RECOVERY, SUPPLY:**
 - **AGM ❄**

Функция используется для зарядки аккумуляторов типа «AGM» или «WET»: свинцово-кислотные, герметичные аккумуляторы с электролитом в абсорбенте, или для зарядки обычных аккумуляторов в условиях температуры ниже 0°C ❄.
 - **RECOVERY**

Дополнительная функция которая позволяет восстановить сульфатированные аккумуляторы.
 - **SUPPLY**

Режим SUPPLY генератора напряжения **Режим не защищен от неправильной полярности, короткого замыкания и неправильно выбранного напряжения.**
5. Общий сигнал тревоги из-за нарушения полярности, короткого замыкания, износившегося или поврежденного аккумулятора.

ФУНКЦИИ

- A. ЗАРЯДКА PULSE-TRONIC
- B. TEST (если предусмотрено)
 - ПРОВЕРКА СОСТОЯНИЯ ЗАРЯДА
 - ПРОВЕРКА ПУСКОВОЙ СПОСОБНОСТИ АККУМУЛЯТОРА (ССА)
 - ПРОВЕРКА ГЕНЕРАТОРА
- C. ОБСЛУЖИВАНИЕ АККУМУЛЯТОРОВ
 - RECOVERY
- D. ПИТАНИЕ
 - SUPPLY (если предусмотрено)

ИНФОРМАЦИЯ О СИГНАЛАХ ТРЕВОГИ

ПОДКЛЮЧЕНИЕ ЗАРЯДНЫХ КАБЕЛЕЙ

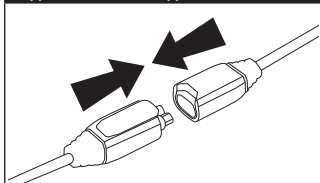

ВКЛЮЧЕНИЕ

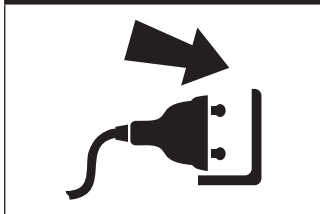

ВЫКЛЮЧЕНИЕ

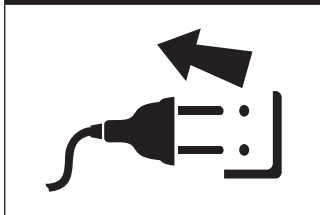

А ЗАРЯДКА/ПОДДЕРЖКА

ТЕХНОЛОГИЯ PULSE-TRONIC



1 ВЫБОР НАПРЯЖЕНИЯ



2 ВЫБОР РЕЖИМА Pulse-Tronic



3 ДОПОЛНИТЕЛЬНО: ВЫБОР РАСШИРЕННОГО МЕНЮ



Дополнительная возможность для более быстрой зарядки

4 ПОДКЛЮЧЕНИЕ ЗАЖИМОВ

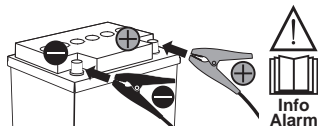

5 ГРАФИК ФАЗ ЗАРЯДКИ PULSE-TRONIC

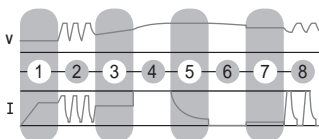

- 1 Проверка аккумулятора
- 2 Импульсное восстановление сульфатированных / глубоко разряженных аккумуляторов
- 3 Проверка целостности
- 4 Зарядка до 80%
- 5 Зарядка до 100%
- 6 Контроль удержания заряда
- 7 Поддержание заряда (*)
- 8 Импульсное восстановление заряда (*)

(*) Этапы поддержания после завершения зарядки.

Их прерывание происходит после отключения зарядного устройства.

6 КОНЕЦ ЗАРЯДА - ПРИМЕР

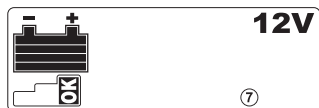

Завершение зарядки Pulse-Tronic - Положительный результат

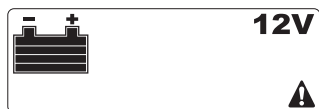

Завершение зарядки Pulse-Tronic - Отрицательный результат

В ПРОВЕРКА

СОСТОЯНИЕ ЗАРЯДА



1 ВЫБОР НАПРЯЖЕНИЯ



2 ВЫБОР ПРОВЕРКИ

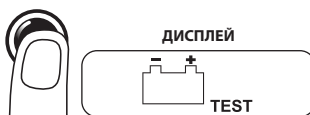

3 ПОДКЛЮЧЕНИЕ ЗАЖИМОВ

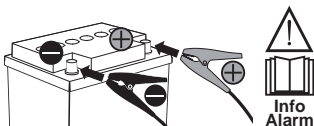

4 КОНЕЦ ПРОВЕРКИ - ПРИМЕР



УСЛОВНЫЕ ОБОЗНАЧЕНИЯ НА ДИСПЛЕЕ



В ПРОВЕРКА

ПУСКОВАЯ СПОСОБНОСТЬ АККУМУЛЯТОРА



1 ВЫБОР НАПРЯЖЕНИЯ



2 ВЫБОР ПРОВЕРКИ



3 ПОДКЛЮЧЕНИЕ ЗАЖИМОВ

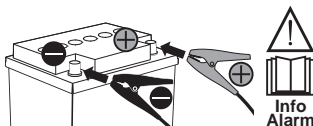

4 ЗАПУСК АВТОМОБИЛЯ



5 КОНЕЦ ПРОВЕРКИ - ПРИМЕР



УСЛОВНЫЕ ОБОЗНАЧЕНИЯ НА ДИСПЛЕЕ



В ПРОВЕРКА

ГЕНЕРАТОР



1 ВЫБОР НАПРЯЖЕНИЯ



2 ВЫБОР ПРОВЕРКИ



3 ПОДКЛЮЧЕНИЕ ЗАЖИМОВ

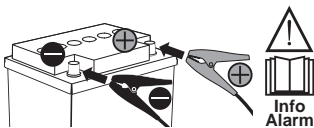

4 ЗАПУСК АВТОМОБИЛЯ



5 КОНЕЦ ПРОВЕРКИ - ПРИМЕР



УСЛОВНЫЕ ОБОЗНАЧЕНИЯ НА ДИСПЛЕЕ



С ТЕХОБСЛУЖИВАНИЕ

ВОССТАНОВЛЕНИЕ



1 ВЫБОР НАПРЯЖЕНИЯ



2 ВЫБОР РАСШИРЕННОГО МЕНЮ



3 ПОДКЛЮЧЕНИЕ ЗАЖИМОВ

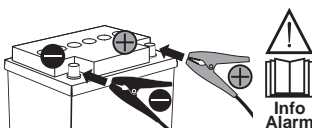

4 КОНЕЦ ПРОЦЕССА - ПРИМЕР



5 ВЫХОД ИЗ ФУНКЦИИ



D ПИТАНИЕ

ИСТОЧНИК
ПИТАНИЯ

SUPPLY

ЗАМЕНА
АККУМУЛЯТОРА

1 ВЫБОР НАПРЯЖЕНИЯ



ДИСПЛЕЙ

12V



Info
Alarm

2 ВЫБОР РАСШИРЕННОГО МЕНЮ



ДИСПЛЕЙ

SUPPLY

3"

3 ПОДКЛЮЧЕНИЕ ЗАЖИМОВ К КАБЕЛЯМ АККУМУЛЯТОРА ТРАНСПОРТНОГО СРЕДСТВА

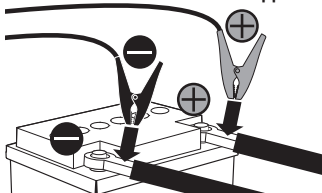

4 ПИТАНИЕ ТРАНСПОРТНОГО СРЕДСТВА ВКЛЮЧЕНО

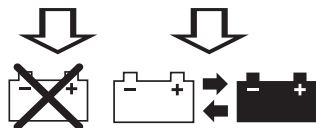

ИЗВЛЕЧЕНИЕ
АККУМУЛЯТОРА

ЗАМЕНА
АККУМУЛЯТОРА

5 ВЫХОД ИЗ ФУНКЦИИ



3"



ИНФОРМАЦИЯ О
СИГНАЛАХ ТРЕВОГИ



Info
Alarm



КОРОТКОЕ
ЗАМЫКАНИЕ

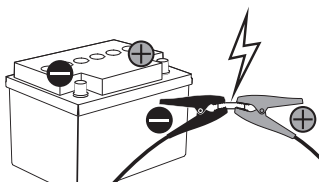

НЕСОБЛЮДЕНИЕ ПОЛЯРНОСТИ

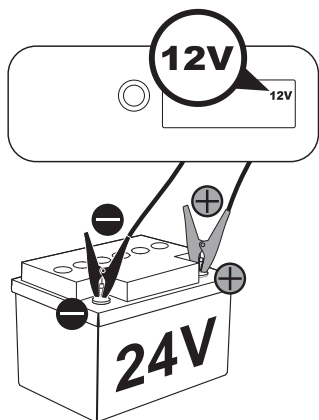
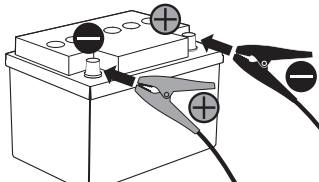

Светодиодная версия

A ЗАРЯДКА/ ПОДДЕРЖАНИЕ

ТЕХНОЛОГИЯ PULSE-TRONIC



1 ВЫБОР НАПРЯЖЕНИЯ

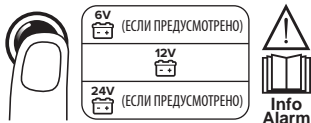

2 ДОПОЛНИТЕЛЬНО: ВЫБОР РАСШИРЕННОГО МЕНЮ



3 ПОДКЛЮЧЕНИЕ ЗАЖИМОВ

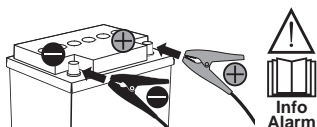

4 КОНЕЦ ЗАРЯДА - ПРИМЕР



Завершение зарядки Pulse-Tronic
Положительный результат



Завершение зарядки Pulse-Tronic
Отрицательный результат

C ТЕХОБСЛУЖИВАНИЕ

ВОССТАНОВЛЕНИЕ



1 ВЫБОР НАПРЯЖЕНИЯ

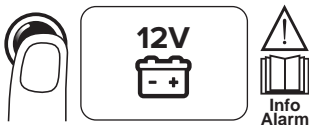

2 ВЫБОР РАСШИРЕННОГО МЕНЮ



3 ПОДКЛЮЧЕНИЕ ЗАЖИМОВ

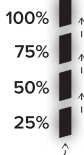
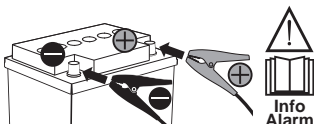

Последовательно мигающие светодиоды означают, что выполняется процедура ВОССТАНОВЛЕНИЯ.

4 КОНЕЦ ПРОЦЕССА - ПРИМЕР



5 ВЫХОД ИЗ ФУНКЦИИ



D ПИТАНИЕ

ИСТОЧНИК
ПИТАНИЯ

SUPPLY

ЗАМЕНА
АККУМУЛЯТОРА

1 ВЫБОР НАПРЯЖЕНИЯ



12V



Info
Alarm

2 ВЫБОР РАСШИРЕННОГО МЕНЮ



3"



SUPPLY

3 ПОДКЛЮЧЕНИЕ ЗАЖИМОВ К КАБЕЛЯМ АККУМУЛЯТОРА ТРАНСПОРТНОГО СРЕДСТВА

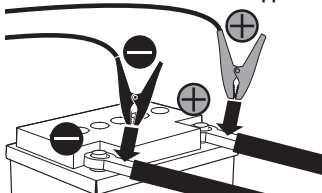

4 ПИТАНИЕ ТРАНСПОРТНОГО СРЕДСТВА ВКЛЮЧЕНО

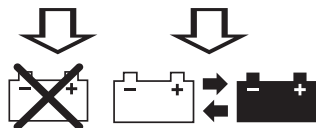

ИЗВЛЕЧЕНИЕ
АККУМУЛЯТОРА ЗАМЕНА
АККУМУЛЯТОРА

5 ВЫХОД ИЗ ФУНКЦИИ



3"



ИНФОРМАЦИЯ О
СИГНАЛАХ ТРЕВОГИ



Info
Alarm



КОРОТКОЕ
ЗАМЫКАНИЕ

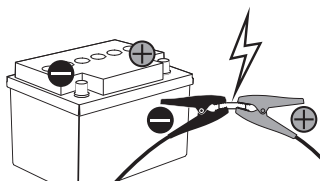

НЕСОБЛЮЖДЕНИЕ ПОЛЯРНОСТИ

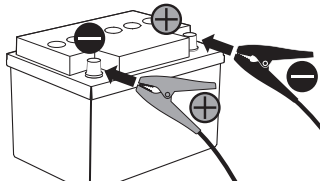

12V

12V



24V

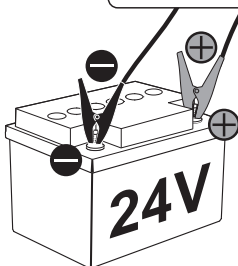

Versão LCD (pág. 2)

- Nível de carga da bateria.
- Escolha da tipologia de bateria:
 - GEL:** baterias de Chumbo-Cálcio (PbCa) de eletrólito sólido tipo gelatinoso completamente seladas. São baterias isentas de manutenção.
 - AGM (ABSORBENT GLASS MAT):** baterias de Chumbo com eletrólito absorvido em fibra de vidro. Completamente seladas. São baterias isentas de manutenção.
 - AGM+:** asseguram um maior número de arranques com uma corrente superior e uma profundidade de descarga mais elevada em comparação com as AGM padrão. Utilizadas em veículos equipados com sistema Start-Stop. Dimensões reduzidas, maior resistência às vibrações e tempos de recarga mais rápidos.
 - Lítio (Li):** baterias de peso reduzido, alta densidade de energia e autodescarga muito baixa. São utilizadas principalmente no mundo dos desportos motorizados.
 - EFB (Enhanced Flooded Battery):** baterias de eletrólito líquido com melhor capacidade de recarga e que suportam um maior número de ciclos (arranques) em comparação com as baterias tradicionais. Ideais para veículos equipados com sistema Start-Stop.
- Carregamento a baixas temperaturas (indicado também para baterias WET).
- Tensão da bateria configurada.
- Modalidade RECOVERY.
Função adicional para recuperar baterias sulfatadas.
- Alarme genérico para inversão de polaridade, curto-circuito, bateria consumida ou avariada.
- Modalidade SUPPLY.
Modalidade SUPPLY gerador de tensão.
Modalidade não protegida contra inversão de polaridade, curto-circuito e seleção errada da tensão.
- Fases de carga PULSE-TRONIC.
- Modalidade BOOST.
Função adicional para carregamento rápido.
- Modalidade TEST.
- Teste do alternador e teste de capacidade de arranque da bateria (CCA).
- Resultado de TEST e RECOVERY e fim de carga.
- Botão de configuração:
 - CARGA PULSE-TRONIC (GEL, AGM, AGM+, Li, EFB e baixas temperaturas ❄).
 - TEST (estado da bateria, capacidade de arranque da bateria, alternador veículo).
 - Programas avançados: BOOST, RECOVERY, SUPPLY.

Versão LED (pág. 2)

- Botão de configuração:
Seleção da tensão de carregamento e programas avançados.
- Tensão da bateria configurada.
- Nível de carga da bateria:
Led 25% : carregamento em curso.
Led 50% : carregamento em curso.
Led 75% : carregamento em curso.
Led 100% : carregamento concluído.

- Programas avançados: **AGM** ❄
RECOVERY, SUPPLY:

• **AGM** ❄

Função útil para carregar uma bateria de tipo "AGM" ou "WET": baterias de chumbo, seladas, com eletrólito em material absorvente, ou para carregar uma bateria genérica em condições de temperatura baixa, abaixo de 0 °C ❄.

• **RECOVERY**

Função adicional para recuperar baterias sulfatadas.

• **SUPPLY**

Modalidade SUPPLY gerador de tensão
Modalidade não protegida contra inversão de polaridade, curto-circuito e seleção errada da tensão.

- Alarme genérico para inversão de polaridade, curto-circuito, bateria consumida ou avariada.

FUNÇÕES

- CARGA PULSE-TRONIC
- TEST (se previsto)
 - TESTE ESTADO DE CARGA
 - TESTE CAPACIDADE DE ARRANQUE DA BATERIA (CCA)
 - TESTE ALTERNADOR
- MANUTENÇÃO DAS BATERIAS
 - RECOVERY
- ALIMENTAÇÃO
 - SUPPLY (se previsto)

INFO ALARMES

LIGAÇÃO CABOS DE CARGA

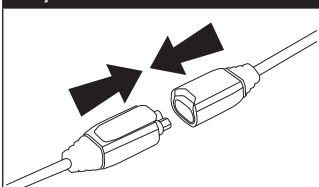

LIGAÇÃO

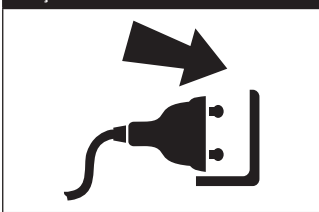

DESLIGAMENTO

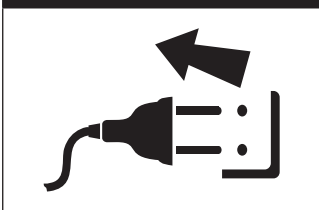

A CARGA/MANUTENÇÃO

PULSE-TRONIC TECHNOLOGY



1 SELEÇÃO TENSÃO

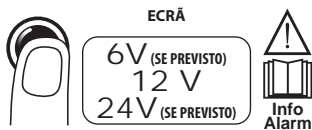

2 SELEÇÃO PROCESSO Pulse-Tronic

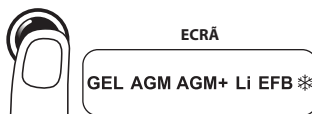

3 OPCIONAL: SELEÇÃO MENU AVANÇADO



Opcional para uma carga mais rápida

4 CONEXÃO PINÇAS

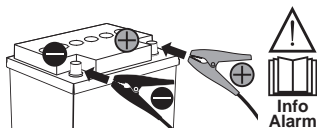

5 GRÁFICO FASES DE CARGA PULSE-TRONIC

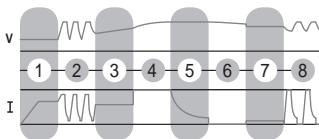

- 1 Teste da bateria
- 2 Recuperação por impulsos de baterias sulfatadas/muito descarregadas
- 3 Controlo da integridade
- 4 Carga até 80%
- 5 Carga até 100%
- 6 Monitor de retenção carga
- 7 Manutenção carga (*)
- 8 Restabelecimento de carga por impulsos (*)

(*) Fase de manutenção após o final da carga. A sua interrupção ocorre depois de desligar o carregador de bateria.

6 FIM DA CARGA - EXEMPLO



Fim de carga Pulse-Tronic - Resultado positivo

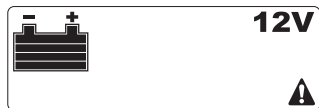

Fim de carga Pulse-Tronic - Resultado negativo

B TESTE

ESTADO DA CARGA



1 SELEÇÃO TENSÃO



ECRÃ

12V



Info Alarm

2 SELEÇÃO TESTE



ECRÃ



TEST

3 CONEXÃO PINÇAS

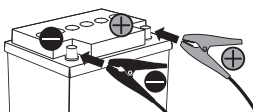

Info Alarm

4 FIM TESTE - EXEMPLO



TEST

12V

LEGENDA ECRÃ



muito descarregada



descarregada



carregada

B TESTE

CAPACIDADE ARRANQUE BATERIA



1 SELEÇÃO TENSÃO



ECRÃ

12V



Info Alarm

2 SELEÇÃO TESTE



ECRÃ



TEST

3 CONEXÃO PINÇAS

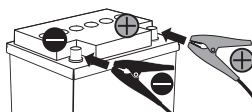

Info Alarm

4 ARRANQUE VEÍCULO



5 FIM TESTE - EXEMPLO



TEST

LEGENDA ECRÃ



positivo



suficiente



negativo

B TESTE

ALTERNADOR



1 SELEÇÃO TENSÃO



ECRÃ

12V



Info Alarm

2 SELEÇÃO TESTE



ECRÃ



TEST

3 CONEXÃO PINÇAS

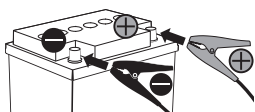

Info Alarm

4 ARRANQUE VEÍCULO



5 FIM TESTE - EXEMPLO

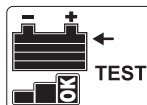

LEGENDA ECRÃ



C MANUTENÇÃO

RECOVERY



1 SELEÇÃO TENSÃO



ECRÃ

12V



Info Alarm

2 SELEÇÃO MENU AVANÇADO



ECRÃ



3"

3 CONEXÃO PINÇAS

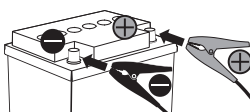

Info Alarm

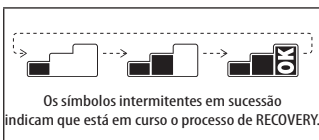

4 FIM DO PROCESSO - EXEMPLO



5 SAÍDA DE FUNÇÃO



3"

D ALIMENTAÇÃO

SUPPLY SUPPLY

TROCA BATERIA

1 SELEÇÃO TENSÃO



ECRÃ

12V



Info Alarm

2 SELEÇÃO MENU AVANÇADO



ECRÃ

SUPPLY

3 CONEXÃO DAS PINÇAS NOS CABOS DA BATERIA DO VEÍCULO

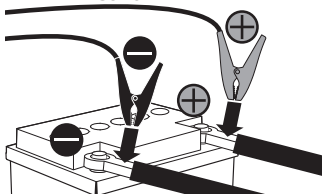

4 VEÍCULO ALIMENTADO



REMOÇÃO BATERIA



SUBSTITUIÇÃO BATERIA

5 SAÍDA DE FUNÇÃO



3"



INFO ALARMES



Info Alarm



CURTO-CIRCUITO

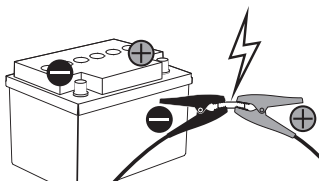

INVERSÃO POLARIDADE

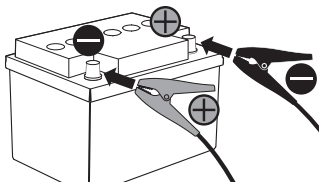

12V

12V

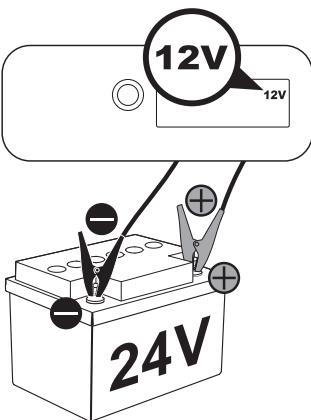

Versão LED

A

CARREGAMENTO/ MANUTENÇÃO

PULSE-TRONIC TECHNOLOGY



1 SELEÇÃO TENSÃO

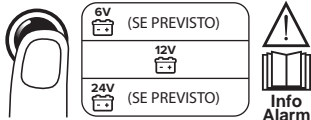

2 OPCIONAL: SELEÇÃO MENU AVANÇADO



3 CONEXÃO PINÇAS

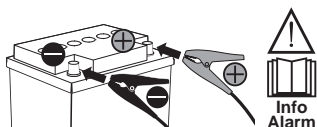

4 FIM DA CARGA - EXEMPLO



Fim de carga Pulse-Tronic - Resultado positivo



Fim de carga Pulse-Tronic - Resultado negativo

C

MANUTENÇÃO

RECOVERY



1 SELEÇÃO TENSÃO

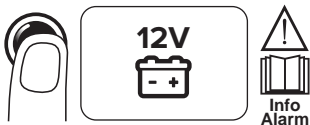

2 SELEÇÃO MENU AVANÇADO



3 CONEXÃO PINÇAS

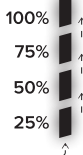
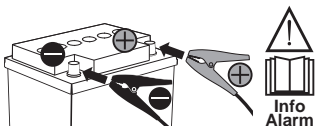

Os LED intermitentes em sucessão indicam que está em curso o processo de RECOVERY.

4 FIM DO PROCESSO - EXEMPLO



5 SAÍDA DE FUNÇÃO



D ALIMENTAÇÃO

SUPPLY

SUPPLY

TROCA BATERIA

1 SELEÇÃO TENSÃO



12V



Info Alarm

2 SELEÇÃO MENU AVANÇADO



3"



SUPPLY

3 CONEXÃO DAS PINÇAS NOS CABOS DA BATERIA DO VEÍCULO

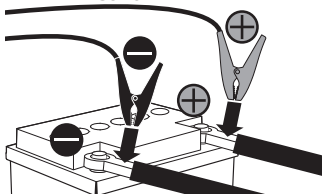

4 VEÍCULO ALIMENTADO



REMOÇÃO BATERIA



SUBSTITUIÇÃO BATERIA

5 SAÍDA DE FUNÇÃO



3"



INFO ALARMES



Info Alarm



CURTO-CIRCUITO

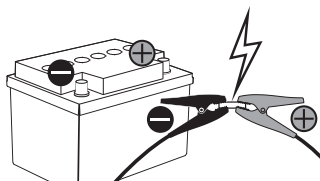

INVERSÃO POLARIDADE

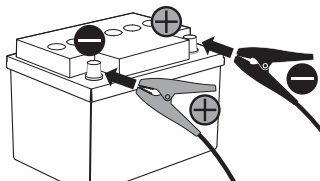

12V

12V



24V

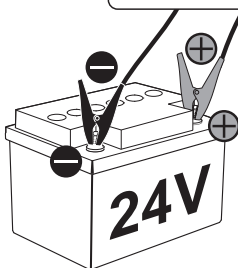

LCD-versie (pag. 2)

- Opladingsniveau van de accu.
- Type accu kiezen:
 - **GEL:** lood-calciumaccu's (PbCa) met solide gelvormige elektrolyt, volledig gesloten. Dit zijn onderhoudsvrije accu's.
 - **AGM (ABSORBENT GLASS MAT):** loodaccu's waarin het elektrolyt wordt vastgehouden door glasvezelmatten. Volledig gesloten. Dit zijn onderhoudsvrije accu's.
 - **AGM+:** garanderen een groter aantal starts met een hogere stroom en een grotere ontladingsdiepte dan de standaard-AGM's. Worden gebruikt in voertuigen met start-stop-systeem. Beperkte afmetingen, hogere weerstand tegen trillingen en snelle laadtijden.
 - **Lithium (Li):** accu's met een beperkt gewicht, een hoge energiedichtheid en zeer lage zelfontlading. Worden voornamelijk gebruikt in de wereld van de motorsport.
 - **EFB (Enhanced Flooded Battery):** accu's met vloeibaar elektrolyt met een beter oplaadvermogen en die een groter aantal cycli (starts) verdragen dan traditionele accu's. Ideaal voor voertuigen met start-stop-systeem.
- Opladen bij lage temperaturen (ook geschikt voor WET-accu's).
- Ingestelde accuspanning.
- Modus RECOVERY.
Extra functie voor het herstellen van gesulfateerde accu's.
- Algemeen alarm voor omgekeerde polariteit, kortsluiting, versleten of defecte accu.
- Modus SUPPLY.
Modus SUPPLY spanningsgenerator.
De modus is niet beschermd tegen omkering van de polariteit, kortsluiting en foute keuze van de spanning.
- Laadfasen PULSE-TRONIC.
- Modus BOOST.
Extra functie voor een snelle lading.
- Modus TEST.
- Test dynamo en Test koudstartstroom van de accu (CCA).
- Uitslag van TEST, RECOVERY en einde laden.
- Instellingstoets:
 - LADEN PULSE-TRONIC (GEL, AGM, AGM+, Li, EFB en lage temperaturen ❄).
 - TEST (accustatus, startcapaciteit accu, dynamo voertuig).
 - Geavanceerde programma's: BOOST, RECOVERY, SUPPLY.

LED-versie (pag. 2)

- Instellingstoets:
Selectie van de laadspanning en geavanceerde programma's.
- Ingestelde accuspanning.
- Opladingsniveau van de accu:
Led 25% : opladen bezig.
Led 50% : opladen bezig.
Led 75% : opladen bezig.
Led 100% : opladen voltooid.
- Geavanceerde programma's: **AGM** ❄,
RECOVERY, SUPPLY:
 - **AGM** ❄

Functie voor het opladen van een accu van het type "AGM" of "WET": loodaccu's, verzegeld, met elektrolyt op absorberend materiaal, of voor het opladen van een algemene accu bij lage temperaturen, onder 0°C ❄.

• RECOVERY

Extra functie voor het herstellen van gesulfateerde accu's.

• SUPPLY

Modus SUPPLY spanningsgenerator

De modus is niet beschermd tegen omkering van de polariteit, kortsluiting en foute keuze van de spanning.

- Algemeen alarm voor omgekeerde polariteit, kortsluiting, versleten of defecte accu.

FUNCTIES

- PULSE-TRONIC LADEN
- TEST (waar voorzien)
 - TEST OPLADINGSNIVEAU
 - TEST KOUDSTARTSTROOM VAN DE ACCU (CCA)
 - TEST DYNAMO
- ONDERHOUD ACCU'S
 - RECOVERY
- VOEDING
 - SUPPLY (waar voorzien)

INFO ALARMEN

AANSLUITING LAADKABELS

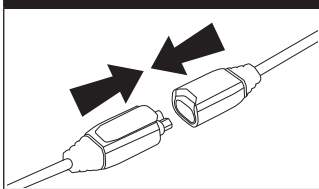

INSCHAKELEN

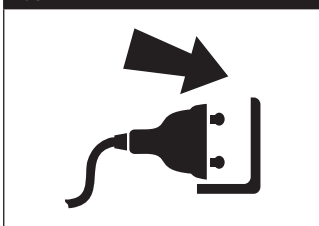

UITSCHAKELEN

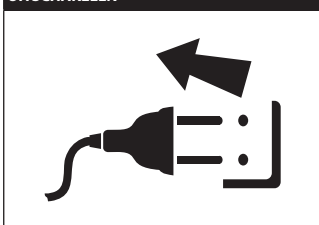

A LADEN/LADINGSBEHOUD

PULSE-TRONIC-TECHNOLOGIE



1 SPANNING SELECTEREN

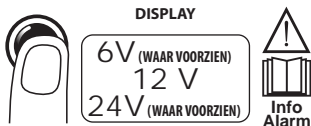

2 SELECTIE PROCES Pulse-Tronic



3 OPTIONEEL: GEAVANCEERD MENU SELECTEREN



Optioneel om sneller te laden

4 KLEMMEN AANSLUITEN

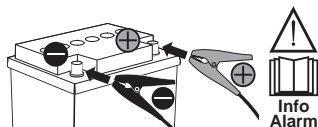

5 GRAFIEK OPLAADFASEN PULSE-TRONIC

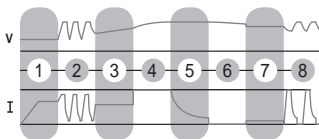

- 1 Test van de accu
- 2 Herstel met pulsen van gesulfateerde/ bijna lege accu's
- 3 Controle van de integriteit
- 4 Lading tot 80%
- 5 Lading tot 100%
- 6 Bewaking behoud van de lading
- 7 Ladingsbehoud (*)
- 8 Herstel lading met pulsen (*)

(*) Fasen ladingsbehoud na het einde van het laden.

Worden onderbroken nadat de acculader is losgekoppeld.

6 EINDE LADING - VOORBEELD



Einde lading Pulse-Tronic - Resultaat positief



Einde lading Pulse-Tronic - Resultaat negatief

B TEST

OPLADINGSNIVEAU 

1 SPANNING SELECTEREN



2 TEST SELECTEREN

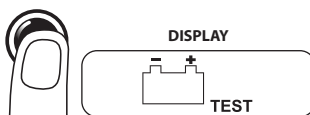

3 KLEMMEN AANSLUITEN

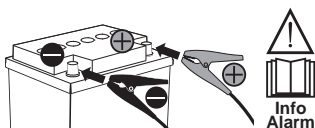

4 EINDE TEST - VOORBEELD



LEGENDA DISPLAY

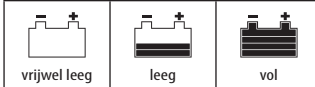

B TEST

STARTCAPACITEIT ACCU 

1 SPANNING SELECTEREN



2 TEST SELECTEREN

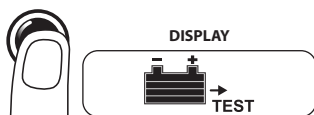

3 KLEMMEN AANSLUITEN

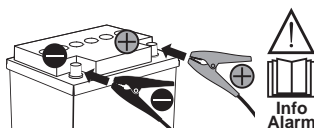

4 VOERTUIG STARTEN



5 EINDE TEST - VOORBEELD



LEGENDA DISPLAY

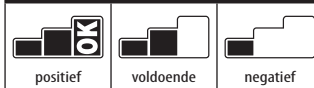

B TEST

ALTERNATOR



1 SPANNING SELECTEREN



2 TEST SELECTEREN

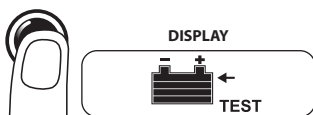

3 KLEMMEN AANSLUITEN

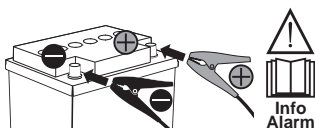

4 VOERTUIG STARTEN



5 EINDE TEST - VOORBEELD



LEGENDA DISPLAY



C ONDERHOUD

RECOVERY



1 SPANNING SELECTEREN

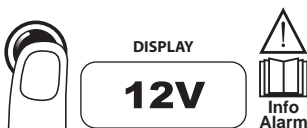

2 GEAVANCEERD MENU SELECTEREN

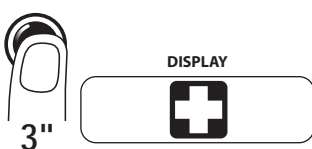

3 KLEMMEN AANSLUITEN

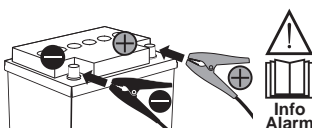

4 EINDE PROCES - VOORBEELD



5 FUNCTIE AFSLUITEN



D VOEDING

SUPPLY SUPPLY

VERVANGEN ACCU

1 SPANNING SELECTEREN



DISPLAY

12V



2 GEAVANCEERD MENU SELECTEREN



DISPLAY

SUPPLY

3 KLEMMEN AANSLUITEN OP ACCUKABELS VOERTUIG

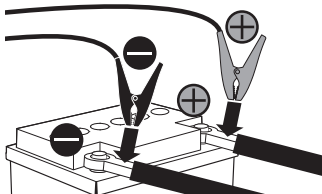

4 VOERTUIG AANGEDREVEN

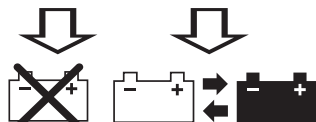

VERWIJDEREN ACCU

VERVANGEN ACCU

5 FUNCTIE AFSLUITEN



3"



INFO ALARMEN



Info Alarm



KORTSLUITING

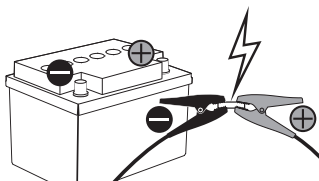

OMKERING VAN DE POLARITEIT

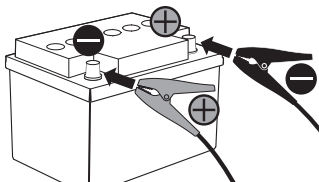

12V

12V

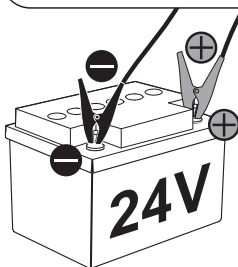

LED-versie

A LADEN/ LADINGSBEHOUD

PULSE-TRONIC-TECHNOLOGIE



1 SPANNING SELECTEREN

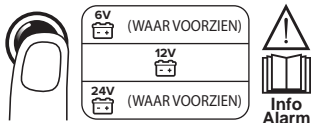

2 OPTIONEEL: GEAVANCEERD MENU SELECTEREN



3 KLEMMEN AANSLUITEN

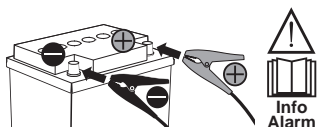

4 EINDE LADING - VOORBEELD



Einde lading Pulse-Tronic - Resultaat positief



Einde lading Pulse-Tronic - Resultaat negatief

C ONDERHOUD

RECOVERY

1 SPANNING SELECTEREN

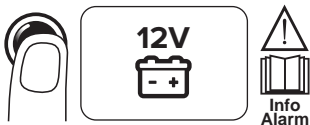

2 GEAVANCEERD MENU SELECTEREN



3 KLEMMEN AANSLUITEN

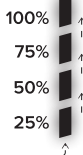
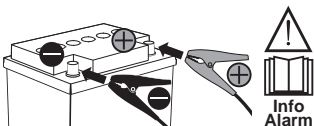

Met na elkaar knipperende symbolen wordt aangegeven dat het RECOVERY-proces bezig is.

4 EINDE PROCES - VOORBEELD



5 FUNCTIE AFSLUITEN



D VOEDING

SUPPLY

SUPPLY

VERVANGEN
ACCU

1 SPANNING SELECTEREN



Info
Alarm

2 GEAVANCEERD MENU SELECTEREN



3"



3 KLEMMEN AANSLUITEN OP ACCUKABELS VOERTUIG

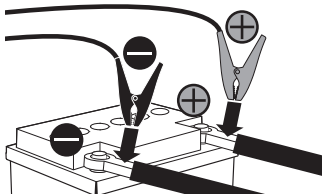

4 VOERTUIG AANGEDREVEN



VERWIJDEREN
ACCU



VERVANGEN
ACCU

5 FUNCTIE AFSLUITEN



3"



INFO
ALARMEN



Info
Alarm



KORTSLUITING

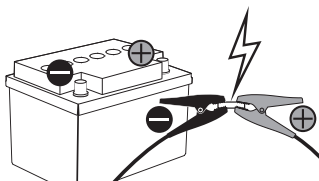

OMKERING VAN DE POLARITEIT

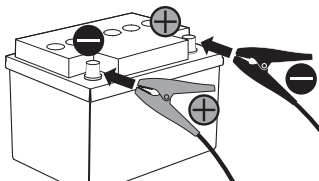

12V

12V



24V

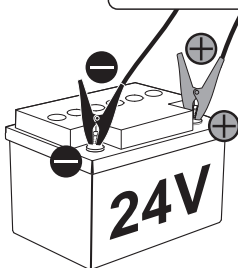

24V

Εκδοχή LCD (σελ. 2)

1. Στάθμη φορτίου μπαταρίας.
2. Επιλογή τύπου μπαταρίας:
 - **GEL**: μπαταρίες Μολύβδου-Ασβεστίου (PbCa) με στερεό ηλεκτρολύτη τύπου gel εντελώς σφραγισμένες. Είναι μπαταρίες χωρίς συντήρηση.
 - **AGM** (ABSORBENT GLASS MAT): μπαταρίες Μολύβδου με απορροφημένο ηλεκτρολύτη σε ίνες γυαλιού. Εντελώς σφραγισμένες. Είναι μπαταρίες χωρίς συντήρηση.
 - **AGM+**: εξασφαλίζουν έναν μεγαλύτερο αριθμό εκκινήσεων σε υψηλότερο ρεύμα και ένα υψηλότερο βάθος εκκένωσης σε σχέση με τις στάνταρντ AGM. Χρησιμοποιούνται σε οχήματα εφοδιασμένα με σύστημα Start-Stop. Ελαττωμένες διαστάσεις, υψηλότερη αντοχή στις δονήσεις και σύντομοι χρόνοι επαναφόρτισης.
 - **Λίθιο (Li)**: μπαταρίες με ελαττωμένο βάρος, υψηλή ενεργειακή πυκνότητα και πολύ χαμηλή αυτοεκφόρτιση. Χρησιμοποιούνται κυρίως στον τομέα των μηχανοκίνητων αθλημάτων.
 - **EFB** (Enhanced Flooded Battery): μπαταρίες με υγρό ηλεκτρολύτη που έχουν μεγαλύτερη ικανότητα επαναφόρτισης και υφίστανται υψηλότερο αριθμό κύκλων (εκκινήσεων) σε σχέση με τις συνήθειες. Ιδανικές για οχήματα εφοδιασμένα με συστήματα Start-Stop.
3. Φόρτιση σε χαμηλές θερμοκρασίες (ενδεικτική ακόμα και για μπαταρίες WET).
4. Προσδιορισμένη τάση μπαταρίας.
5. Τρόπος RECOVERY.
Πρόσθετη λειτουργία για την ανάκτηση των θεικών μπαταριών.
6. Γενικός συναγεμμός για αντιστροφή πολικότητας, βραχυκύκλωμα, μπαταρία φθαρμένη ή με βλάβη.
7. Τρόπος SUPPLY.
Τρόπος SUPPLY, γεννήτρια τάσης.
Τρόπος μη προστατευόμενος από αντιστροφή πολικότητας, βραχυκύκλωμα και εσφαλμένη επιλογή τάσης.
8. Φάσεις φόρτισης PULSE-TRONIC.
9. Τρόπος BOOST.
Πρόσθετη λειτουργία για γρήγορη φόρτιση.
10. Τρόπος TEST.
11. Τεστ εναλλακτήρα και Τεστ ικανότητας εκκίνησης μπαταρίας (CCA).
12. Αποτέλεσμα TEST, RECOVERY και τέλος φόρτισης.
13. Πλήκτρο ρύθμισης:
 - ΦΟΡΤΙΣΗ PULSE-TRONIC (GEL, AGM, AGM +, Li, EFB και χαμηλές θερμοκρασίες *).
 - ΤΕΣΤ (κατάσταση μπαταρίας, ικανότητα εκκίνησης μπαταρίας, εναλλακτήρα οχήματος).
 - Προχωρημένα προγράμματα: BOOST, RECOVERY, SUPPLY.

Εκδοχή LED (σελ. 2)

1. Πλήκτρο ρύθμισης:
Επιλογή τάσης φόρτισης και προχωρημένα προγράμματα.
2. Προσδιορισμένη τάση μπαταρίας.
3. Στάθμη φορτίου μπαταρίας:
Λεντ 25% : φόρτιση σε εξέλιξη.
Λεντ 50% : φόρτιση σε εξέλιξη.
Λεντ 75% : φόρτιση σε εξέλιξη.

Λεντ 100% : τέλος φόρτισης.

4. Προχωρημένα Προγράμματα: **AGM** ❄️, **RECOVERY**, **SUPPLY**:
 - **AGM** ❄️
Λειτουργία χρήσιμη για φόρτιση μπαταρίας τύπου "AGM" ή "WET": μπαταρίες μολύβδου, σφραγισμένες, με ηλεκτρολύτη σε απορροφητικό υλικό, ή, για φόρτιση μπαταρίας γενικού τύπου σε συνθήκες χαμηλής θερμοκρασίας, κάτω από 0°C ❄️.
 - **RECOVERY**
Πρόσθετη λειτουργία για την ανάκτηση των θεικών μπαταριών.
 - **SUPPLY**
Τρόπος SUPPLY γεννήτρια τάσης
Τρόπος μη προστατευόμενος από αντιστροφή πολικότητας, βραχυκύκλωμα και εσφαλμένη επιλογή τάσης.
5. Γενικός συναγεμμός για αντιστροφή πολικότητας, βραχυκύκλωμα, μπαταρία φθαρμένη ή με βλάβη.

ΛΕΙΤΟΥΡΓΙΕΣ

- A. ΦΟΡΤΙΣΗ PULSE-TRONIC
- B. ΤΕΣΤ (όπου προβλέπεται)
 - ΤΕΣΤ ΚΑΤΑΣΤΑΣΗΣ ΦΟΡΤΙΟΥ
 - ΤΕΣΤ ΙΚΑΝΟΤΗΤΑΣ ΕΚΚΙΝΗΣΗΣ ΜΠΑΤΑΡΙΑΣ (CCA)
 - ΤΕΣΤ ΕΝΑΛΛΑΚΤΗΡΑ
- C. ΣΥΝΤΗΡΗΣΗ ΜΠΑΤΑΡΙΩΝ
 - RECOVERY
- D. ΤΡΟΦΟΔΟΣΙΑ
 - SUPPLY (όπου προβλέπεται)

ΠΛΗΡΟΦΟΡΙΕΣ ΣΥΝΑΓΕΡΜΩΝ

ΣΥΝΔΕΣΗ ΚΑΛΩΔΙΩΝ ΦΟΡΤΙΣΗΣ

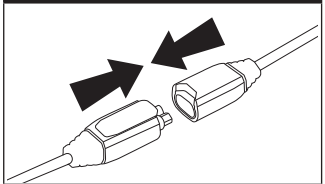

ΕΝΕΡΓΟΠΟΙΗΣΗ

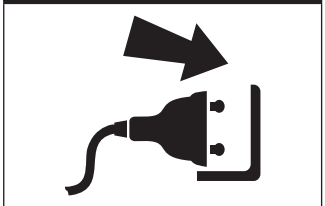

ΣΒΗΣΙΜΟ

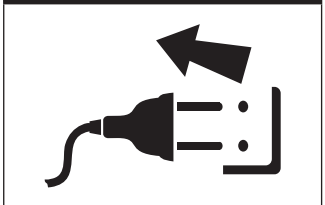

A ΦΟΡΤΙΣΗ/ΣΥΝΤΗΡΗΣΗ

PULSE-TRONIC TECHNOLOGY



1 ΕΠΙΛΟΓΗ ΤΑΣΗΣ



2 ΕΠΙΛΟΓΗ ΔΙΑΔΙΚΑΣΙΑΣ Pulse-Tronic

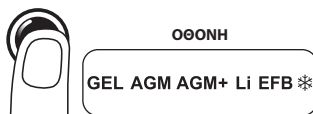

3 ΟΠΣΙΟΝΑΛ: ΕΠΙΛΟΓΗ ΠΡΟΧΩΡΗΜΕΝΟΥ ΜΕΝΟΥ



Όψιοναλ για γρηγορότερη φόρτιση

4 ΣΥΝΔΕΣΗ ΛΑΒΙΔΩΝ

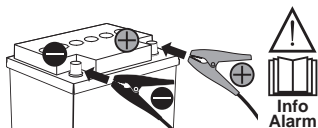

5 ΓΡΑΦΙΚΗ ΠΑΡΑΣΤΑΣΗ ΦΟΡΤΙΣΗΣ PULSE-TRONIC

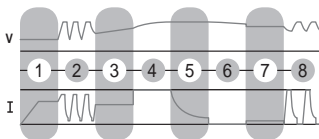

- 1 Τεστ μπαταρίας
- 2 Παλμική επαναφορά θειωμένων/πολύ εκφορτισμένων μπαταριών
- 3 Έλεγχος ακεραιότητας
- 4 Φόρτιση μέχρι 80%
- 5 Φόρτιση μέχρι 100%
- 6 Οθόνη κρατήματος μπαταρίας
- 7 Διατήρηση φορτίου (*)
- 8 Αποκατάσταση φορτίου με παλμούς (*)

(*) Φάσεις διατήρησης μετά το τέλος της φόρτισης.

Η διακοπή τους γίνεται μετά την αποσύνδεση του φορτιστή μπαταρίας.

6 ΤΕΛΟΣ ΦΟΡΤΙΣΗΣ - ΠΑΡΑΔΕΙΓΜΑ



Τέλος φόρτισης Pulse-Tronic - Αποτέλεσμα θετικό

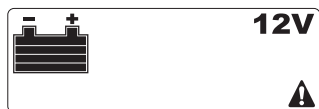

Τέλος φόρτισης Pulse-Tronic - Αποτέλεσμα αρνητικό

B ΤΕΣΤ

ΚΑΤΑΣΤΑΣΗ ΦΟΡΤΙΟΥ



1 ΕΠΙΛΟΓΗ ΤΑΣΗΣ



ΟΘΟΝΗ

12V



2 ΕΠΙΛΟΓΗ ΤΕΣΤ



ΟΘΟΝΗ



3 ΣΥΝΔΕΣΗ ΛΑΒΙΔΩΝ

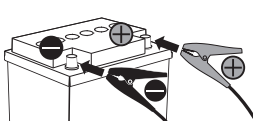

4 ΤΕΛΟΣ ΤΕΣΤ - ΠΑΡΑΔΕΙΓΜΑ



12V

TEST

ΛΕΞΑΝΤΑ ΟΘΟΝΗΣ



πολύ
εκφορτισμένη



εκφορτισμένη



φορτισμένη

B ΤΕΣΤ

ΙΚΑΝΟΤΗΤΑ ΕΚΚΙΝΗΣΗΣ
ΜΠΑΤΑΡΙΑΣ



1 ΕΠΙΛΟΓΗ ΤΑΣΗΣ



ΟΘΟΝΗ

12V



2 ΕΠΙΛΟΓΗ ΤΕΣΤ



ΟΘΟΝΗ



3 ΣΥΝΔΕΣΗ ΛΑΒΙΔΩΝ

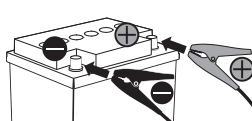

4 ΕΚΚΙΝΗΣΗ ΟΧΗΜΑΤΟΣ



5 ΤΕΛΟΣ ΤΕΣΤ - ΠΑΡΑΔΕΙΓΜΑ



TEST

ΛΕΞΑΝΤΑ ΟΘΟΝΗΣ



θετικό



επαρκές



αρνητικό

B ΤΕΣΤ

ΕΝΑΛΛΑΚΤΗΡΑΣ



1 ΕΠΙΛΟΓΗ ΤΑΣΗΣ



2 ΕΠΙΛΟΓΗ ΤΕΣΤ

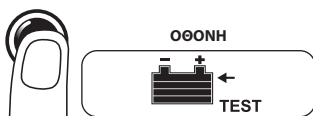

3 ΣΥΝΔΕΣΗ ΛΑΒΙΔΩΝ

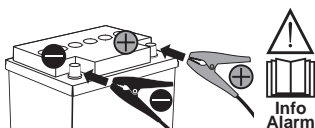

4 ΕΚΚΙΝΗΣΗ ΟΧΗΜΑΤΟΣ



5 ΤΕΛΟΣ ΤΕΣΤ - ΠΑΡΑΔΕΙΓΜΑ



ΛΕΞΑΝΤΑ ΟΘΟΝΗΣ



C ΣΥΝΤΗΡΗΣΗ

RECOVERY



1 ΕΠΙΛΟΓΗ ΤΑΣΗΣ



2 ΕΠΙΛΟΓΗ ΠΡΟΧΩΡΗΜΕΝΟΥ ΜΕΝΟΥ



3 ΣΥΝΔΕΣΗ ΛΑΒΙΔΩΝ

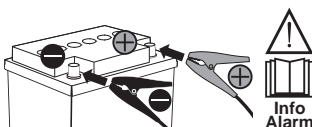

4 ΤΕΛΟΣ ΔΙΑΔΙΚΑΣΙΑΣ - ΠΑΡΑΔΕΙΓΜΑ



5 ΕΞΟΔΟΣ ΑΠΟ ΛΕΙΤΟΥΡΓΙΑ



D ΤΡΟΦΟΔΟΣΙΑ

SUPPLY

SUPPLY

ΑΛΛΑΓΗ
ΜΠΑΤΑΡΙΑ

1 ΕΠΙΛΟΓΗ ΤΑΣΗΣ



ΘΘΟΝΗ

12V



Info
Alarm

2 ΕΠΙΛΟΓΗ ΠΡΟΧΩΡΗΜΕΝΟΥ ΜΕΝΟΥ



3"

ΘΘΟΝΗ

SUPPLY

3 ΣΥΝΔΕΣΗ ΛΑΒΙΔΩΝ ΣΕ ΚΑΛΩΔΙΑ ΜΠΑΤΑΡΙΑΣ ΟΧΗΜΑΤΟΣ

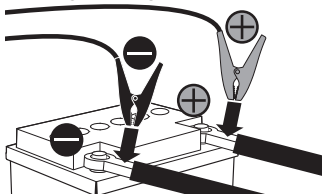

4 ΟΧΗΜΑ ΤΡΟΦΟΔΟΤΗΜΕΝΟ



ΜΕΤΑΚΙΝΗΣΗ
ΜΠΑΤΑΡΙΑ



ΑΝΤΙΚΑΤΑΣΤΑΣΗ
ΜΠΑΤΑΡΙΑ

5 ΕΞΟΔΟΣ ΑΠΟ ΛΕΙΤΟΥΡΓΙΑ



3"



ΠΛΗΡΟΦΟΡΙΕΣ
ΣΥΝΑΓΕΡΜΩΝ



Info
Alarm



ΒΡΑΧΥΚΥΚΛΩΜΑ

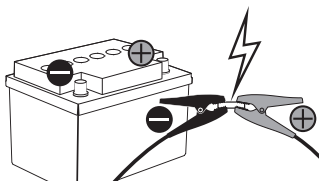

ΑΝΤΙΣΤΡΟΦΗ ΠΟΛΙΚΟΤΗΤΑΣ

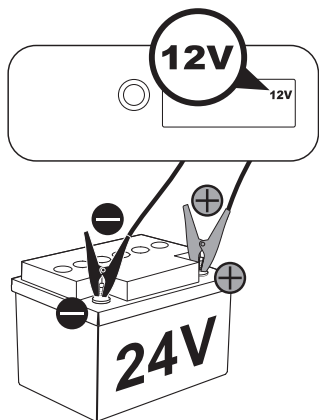
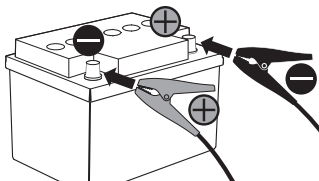

Εκδοχή LED

A

ΦΟΡΤΙΣΗ/ ΣΥΝΤΗΡΗΣΗ

PULSE-TRONIC TECHNOLOGY



1 ΕΠΙΛΟΓΗ ΤΑΣΗΣ

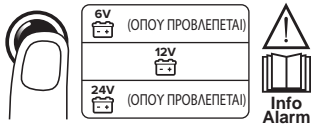

2 ΟΠΣΙΟΝΑΛ: ΕΠΙΛΟΓΗ ΠΡΟΧΩΡΗΜΕΝΟΥ ΜΕΝΟΥ



3 ΣΥΝΔΕΣΗ ΛΑΒΙΔΩΝ

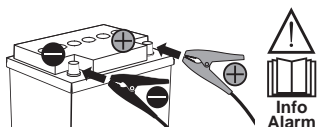

4 ΤΕΛΟΣ ΦΟΡΤΙΣΗΣ - ΠΑΡΑΔΕΙΓΜΑ



Τέλος φόρτισης Pulse-Tronic - Αποτέλεσμα θετικό



Τέλος φόρτισης Pulse-Tronic - Αποτέλεσμα αρνητικό

C

ΣΥΝΤΗΡΗΣΗ

RECOVERY

1 ΕΠΙΛΟΓΗ ΤΑΣΗΣ

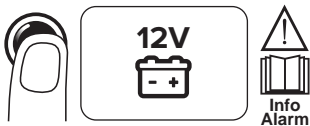

2 ΕΠΙΛΟΓΗ ΠΡΟΧΩΡΗΜΕΝΟΥ ΜΕΝΟΥ



3 ΣΥΝΔΕΣΗ ΛΑΒΙΔΩΝ

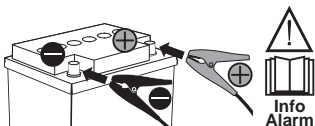

Διαδοχικά αναβοσβηνόμενα λεντ δείχνουν ότι η διαδικασία RECOVERY είναι σε εξέλιξη.

4 ΤΕΛΟΣ ΔΙΑΔΙΚΑΣΙΑΣ - ΠΑΡΑΔΕΙΓΜΑ



5 ΕΞΟΔΟΣ ΑΠΟ ΛΕΙΤΟΥΡΓΙΑ



D ΤΡΟΦΟΔΟΣΙΑ

SUPPLY

SUPPLY

ΑΛΛΑΓΗ
ΜΠΑΤΑΡΙΑ

1 ΕΠΙΛΟΓΗ ΤΑΣΗΣ



12V



Info
Alarm

2 ΕΠΙΛΟΓΗ ΠΡΟΧΩΡΗΜΕΝΟΥ ΜΕΝΟΥ



3"

SUPPLY

3 ΣΥΝΔΕΣΗ ΛΑΒΙΔΩΝ ΣΕ ΚΑΛΩΔΙΑ ΜΠΑΤΑΡΙΑΣ ΟΧΗΜΑΤΟΣ

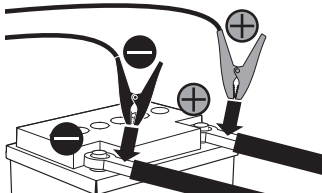

4 ΟΧΗΜΑ ΤΡΟΦΟΔΟΤΗΜΕΝΟ



ΜΕΤΑΚΙΝΗΣΗ
ΜΠΑΤΑΡΙΑ



ΑΝΤΙΚΑΤΑΣΤΑΣΗ
ΜΠΑΤΑΡΙΑ

5 ΕΞΟΔΟΣ ΑΠΟ ΛΕΙΤΟΥΡΓΙΑ



3"



ΠΛΗΡΟΦΟΡΙΕΣ
ΣΥΝΑΓΕΡΜΩΝ



Info
Alarm



ΒΡΑΧΥΚΥΚΛΩΜΑ

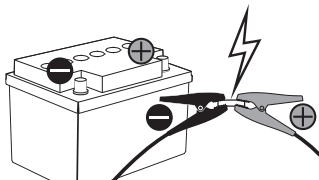

ΑΝΤΙΣΤΡΟΦΗ ΠΟΛΙΚΟΤΗΤΑΣ

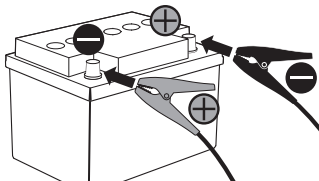

12V

12V



24V

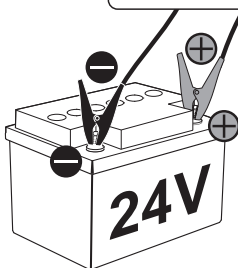

Versiune LCD (pag. 2)

- Nivel de încărcare a bateriei.
- Alegere tip baterie:
 - GEL:** baterii cu plumb-calcium (PbCa) cu electrolit solid de tip gelatinos, complet sigilate. Nu au nevoie de mentenanță.
 - AGM (ABSORBENT GLASS MAT):** baterii cu plumb cu electrolit absorbit în fibră de sticlă. Complet sigilate. Nu au nevoie de mentenanță.
 - AGM+:** garantează un număr mai mare de porniri la o valoare a curentului mai ridicată și o descărcare mai profundă decât bateriile AGM standard. Utilizate la vehicule dotate cu sistem start-stop. Dimensiuni reduse, rezistență la vibrații sporită și timp mic de încărcare.
 - Litiu (Li):** baterii cu greutate scăzută, densitate energetică mare și nivel foarte scăzut de auto-descărcare. Sunt folosite mai ales în sectorul motociclismului.
 - EFB (Enhanced Flooded Battery):** baterii cu electrolit lichid cu capacitate de încărcare îmbunătățită și care suportă un număr de cicluri (porniri) mai mare decât cele tradiționale. Ideale pentru vehicule dotate cu sistem start-stop.
- Încărcare la temperaturi scăzute (indicat și la baterii WET).
- Tensiune baterie setată.
- Modalitatea RECOVERY.
Funcție suplimentară de recuperare baterii sulfatate.
- Alarmă generică pentru inversare polaritate, scurtcircuit, baterie uzată sau defectă.
- Modalitate SUPPLY.
Modalitate SUPPLY generator de tensiune.
Modalitate neprotejată de inversare polaritate, scurtcircuit sau selectare greșită tensiune.
- Fază încărcare PULSE-TRONIC.
- Modalitate BOOST.
Funcție suplimentară pentru încărcare rapidă.
- Modalitate TEST.
- Test alternator și Test capacitate pornire baterie (CCA).
- Rezultat TEST, RECOVERY și finalizare încărcare.
- Buton setare:
 - ÎNCĂRCARE PULSE-TRONIC (GEL, AGM, AGM +, Li, EFB și temperaturi scăzute ❄).
 - TEST (stare baterie, capacitate pornire baterie, alternator vehicul).
 - Programe Avansate: BOOST, RECOVERY, SUPPLY.

Versiune LED (pag. 2)

- Buton setare:
Selectare tensiune de încărcare și programe avansate.
- Tensiune baterie setată.
- Nivel de încărcare a bateriei:
 - Led 25% :** încărcare în curs.
 - Led 50% :** încărcare în curs.
 - Led 75% :** încărcare în curs.
 - Led 100% :** sfârșit încărcare.
- Programe Avansate: **AGM ❄, RECOVERY, SUPPLY:**

• **AGM ❄**

Funcție folosită la încărcarea unei baterii "AGM" sau "WET": baterii cu plumb, sigilate, cu electrolit pe material absorbant, sau pentru încărcarea unei baterii generice în condiții de temperatură scăzută, sub 0°C ❄.

• **RECOVERY**

Funcție suplimentară de recuperare baterii sulfatate.

• **SUPPLY**

Modalitate SUPPLY generator de tensiune

Modalitate neprotejată de inversare polaritate, scurtcircuit sau selectare greșită tensiune.

- Alarmă generică pentru inversare polaritate, scurtcircuit, baterie uzată sau defectă.

FUNCȚII

- ÎNCĂRCARE PULSE-TRONIC
- TEST (dacă este prevăzut)
 - TEST STARE DE ÎNCĂRCARE
 - TEST CAPACITATE PORNIRE BATERIE (CCA)
 - TEST ALTERNATOR
- MENTENANȚĂ BATERII
 - RECOVERY
- ALIMENTARE
 - SUPPLY (dacă este prevăzut)

INFO ALARME

CONECTARE CABLURI DE ÎNCĂRCARE

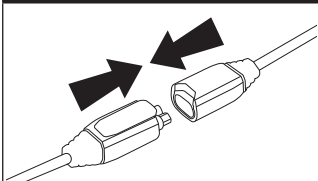

APRINDERE

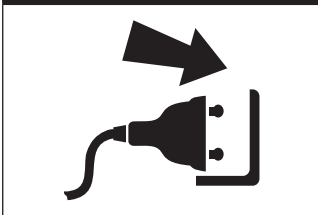

STINGERE

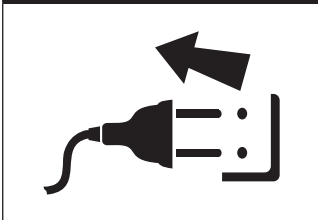

A ÎNCĂRCARE/MENTENANȚĂ

PULSE-TRONIC TECHNOLOGY



1 SELECTARE TENSIUNE

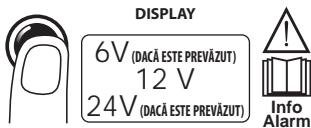

2 SELECTARE PROCES Pulse-Tronic



3 OPȚIONAL: SELECTARE MENU AVANSAT



Opțional pentru o încărcare mai rapidă

4 CONECTARE CLEȘTI

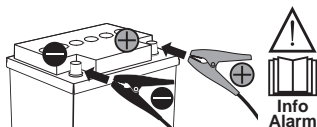

5 GRAFIC FAZE DE ÎNCĂRCARE PULSE-TRONIC

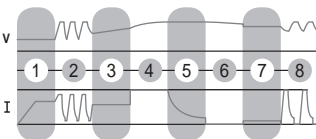

- 1 Test baterie
- 2 Recuperare cu impulsuri baterii sulfatate/foarte descărcate
- 3 Control integritate
- 4 Încărcare până la 80%
- 5 Încărcare până la 100%
- 6 Monitorizare menținere încărcare
- 7 Menținere încărcare (*)
- 8 Restabilire încărcare cu impulsuri (*)

(*) Faze de mentenanță după finalizarea încărcării.

Înteruperea acestora are loc doar după deconectarea încărcătorului.

6 SFÂRȘIT ÎNCĂRCARE - EXEMPLU

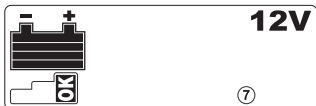

Sfârșit încărcare Pulse-Tronic - Rezultat pozitiv



Sfârșit încărcare Pulse-Tronic - Rezultat negativ

B TEST

STAREA ÎNCĂRCĂRII



1 SELECTARE TENSIUNE



DISPLAY

12V



Info Alarm

2 SELECTARE TEST



DISPLAY



TEST

3 CONECTARE CLEȘTI

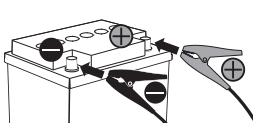

Info Alarm

4 SFÂRȘIT TEST - EXEMPLU



TEST

12V

LEGENDĂ DISPLAY



foarte descărcată



descărcată



încărcată

B TEST

CAPACITATE DE PORNIRE BATERIE



1 SELECTARE TENSIUNE



DISPLAY

12V



Info Alarm

2 SELECTARE TEST



DISPLAY



TEST

3 CONECTARE CLEȘTI

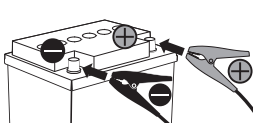

Info Alarm

4 PORNIRE VEHICUL



5 SFÂRȘIT TEST - EXEMPLU



TEST

LEGENDĂ DISPLAY



pozitiv



suficient



negativ

B TEST

ALTERNATOR



1 SELECTARE TENSIUNE



DISPLAY

12V



Info Alarm

2 SELECTARE TEST



DISPLAY



TEST

3 CONECTARE CLEȘTI

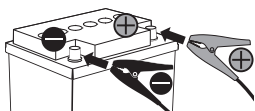

Info Alarm

4 PORNIRE VEHICUL



5 SFÂRȘIT TEST - EXEMPLU

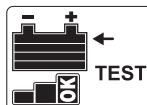

LEGENDĂ DISPLAY



pozitiv



suficient



negativ

C ÎNTREȚINEREA

RECOVERY



1 SELECTARE TENSIUNE



DISPLAY

12V



Info Alarm

2 SELECTARE MENU AVANSAT



DISPLAY



3"

3 CONECTARE CLEȘTI

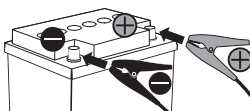

Info Alarm

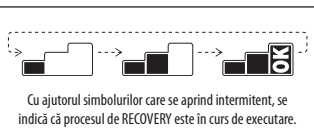

4 SFÂRȘIT PROCES - EXEMPLU



5 IEȘIRE DIN FUNCȚIE



3"

D ALIMENTARE

SUPPLY SUPPLY

INLOCUIRE
BATERIE

1 SELECTARE TENSIUNE



DISPLAY

12V



Info
Alarm

2 SELECTARE MENU AVANSAT



DISPLAY

SUPPLY

3"

3 CONECTARE CEȘTI LA CABLURI BATERIE VEHICUL

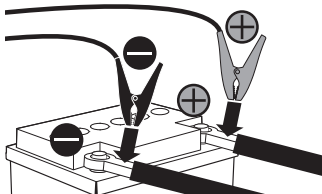

4 VEHICUL ALIMENTAT



DEMONTARE
BATERIE



ÎNLOCUIRE
BATERIE

5 IEȘIRE DIN FUNCȚIE



3"



INFO
ALARME



Info
Alarm



SCURT CIRCUIT

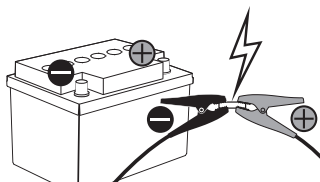

INVERSARE POLARITATE

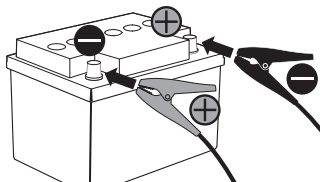

12V

12V

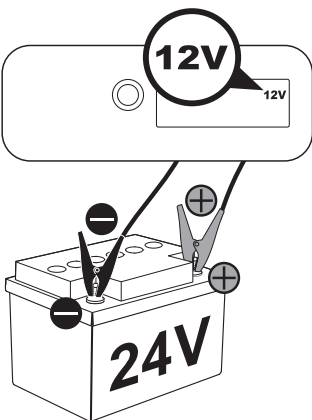

24V

Versiune LED

A ÎNCĂRCARE/ ÎNTREȚINERE

PULSE-TRONIC TECHNOLOGY



1 SELECTARE TENSIUNE

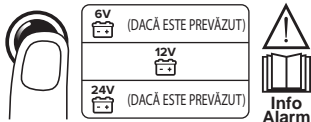

2 OPȚIONAL: SELECTARE MENIU AVANSAT



3 CONECTARE CLEȘTI

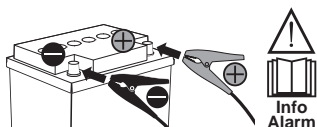

4 SFÂRȘIT ÎNCĂRCARE - EXEMPLU



Sfârșit încărcare Pulse-Tronic - Rezultat pozitiv



Sfârșit încărcare Pulse-Tronic - Rezultat negativ

C ÎNTREȚINEREA

RECOVERY



1 SELECTARE TENSIUNE

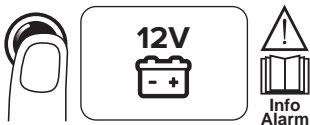

2 SELECTARE MENU AVANSAT



3 CONECTARE CLEȘTI

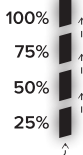
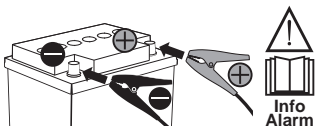

Ledurile care se aprind intermitent indică că procesul de RECOVERY este în curs de executare.

4 SFÂRȘIT PROCES - EXEMPLU



5 IEȘIRE DIN FUNCȚIE



D ALIMENTARE

SUPPLY

SUPPLY

INLOCUIRE
BATERIE

1 SELECTARE TENSIUNE



12V



Info
Alarm

2 SELECTARE MENU AVANSAT



3"



SUPPLY

3 CONECTARE CEȘTI LA CABLURI BATERIE VEHICUL

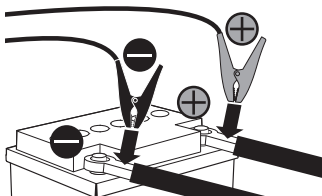

4 VEHICUL ALIMENTAT



DEMONTARE
BATERIE



ÎNLOCUIRE
BATERIE

5 IEȘIRE DIN FUNCȚIE



3"



INFO
ALARME



Info
Alarm



SCURT CIRCUIT

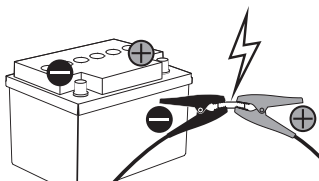

INVERSARE POLARITATE

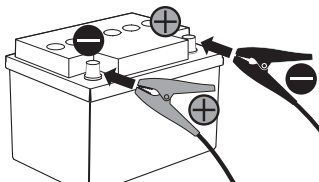

12V

12V



24V

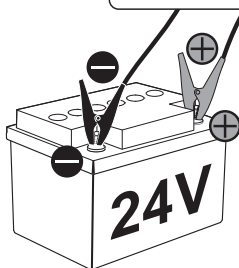

LCD-version (sid. 2)

- Batteriets laddningsnivå.
- Val av batterityp:
 - **GEL:** Helt slutna blykalciumbatterier (PbCa) med fast elektrolyt i gelform. De är underhållsfria batterier.
 - **AGM (ABSORBENT GLASS MAT):** blybatterier där elektrolyten är absorberad i en glasfibernatta. De är helt slutna. De är underhållsfria batterier.
 - **AGM+:** Garanterar ett större antal startcykler med högre ström och ett större urladdningsdjup än vanliga AGM-batterier. De används i fordon med Start-Stop-system. De är mindre i storlek, har större vibrationsmotstånd och kortare laddningstid.
 - **Litium (Li):** Batterier med låg vikt, hög energitäthet och mycket låg självurladdning. De används främst i motorsportsvärlden.
 - **EFB (Enhanced Flooded Battery):** batterier med flytande elektrolyt med bättre laddningskapacitet och som klarar ett högre antal cykler (startcykler) än konventionella batterier. Perfekta för fordon med Start-Stop-system.
- Laddning vid låga temperaturer (även lämplig för WET-batterier).
- Inställd batterispänning.
- Läge RECOVERY.
Extrafunktion, för att återställa sulfaterade batterier.
- Allmänt larm för omvänd polaritet, kortslutning, förbrukat batteri eller batterifel.
- Läge SUPPLY.
Läge SUPPLY spänningsgenerator.
Detta läge är inte skyddat mot omvänd polaritet, kortslutning och felaktigt spänningsval.
- Laddningsfaser PULSE-TRONIC.
- Läge BOOST.
Extra funktion för snabbbladdning.
- Läge TEST.
- Test av generator och test av batteriets startkapacitet (CCA).
- Testresultat, RECOVERY och avslutad laddning.
- Inställningsknapp:
 - LADDNING PULSE-TRONIC (GEL, AGM, AGM +, Li, EFB och låg temperatur ❄).
 - TEST (batteristatus, batteriets startkapacitet, fordonets generator).
 - Avancerade program: BOOST, RECOVERY, SUPPLY.

LED-version (sid. 2)

- Inställningsknapp:
Val av laddningsspänning och avancerade program.
- Inställd batterispänning.
- Batteriets laddningsnivå:
 - Led 25% :** laddning pågår.
 - Led 50% :** laddning pågår.
 - Led 75% :** laddning pågår.
 - Led 100% :** laddning klar.
- Avancerade program: **AGM ❄, RECOVERY, SUPPLY:**
 - **AGM ❄**
Funktion som används för att ladda

batterier av typ "AGM" eller "WET": blybatterier, slutna, med elektrolyt på absorberande material eller för att ladda ett generiskt batteri i kallt klimat, under 0 °C ❄

• RECOVERY

Extrafunktion, för att återställa sulfaterade batterier.

• SUPPLY

Läge SUPPLY spänningsgenerator

Detta läge är inte skyddat mot omvänd polaritet, kortslutning och felaktigt spänningsval.

- Allmänt larm för omvänd polaritet, kortslutning, förbrukat batteri eller batterifel.

FUNKTIONER

- LADDNING PULSE-TRONIC
- TEST (på vissa modeller)
 - TEST AV LADDNINGSTILLSTÅND
 - TEST AV BATTERIETS STARTKAPACITET (CCA)
 - TEST AV GENERATOR
- BATTERIUNDERHÅLL
 - RECOVERY
- STRÖMFÖRSÖRJNING
 - SUPPLY (på vissa modeller)

INFORMATION OM LARM

ANSLUTNING AV LADDNINGSKABLAR

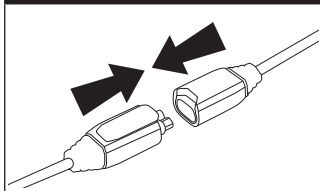

TILLSLAG

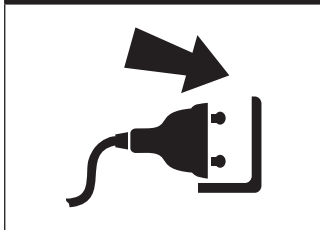

FRÅNSLAG

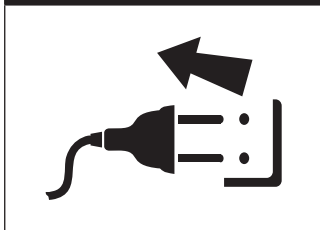

A LADDNING/BIBEHÅLLANDE

PULSE-TRONIC TECHNOLOGY



1 VÄLJA SPÄNNING

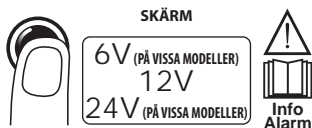

2 VÄLJA PROCESS Pulse-Tronic



3 TILLVAL: VÄLJA AVANCERAD MENY



Tillval för en snabbare laddning

4 ANSLUTA KLÄMMORNA

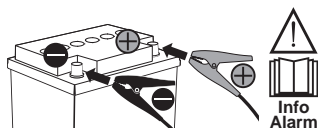

5 DIAGRAM ÖVER LADDNINGSFASER PULSE-TRONIC

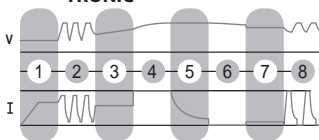

- 1 Batteritest
- 2 Puls-återställning av sulfaterade/mycket urladdade batterier
- 3 Kontroll av skick
- 4 Laddning upp till 80%
- 5 Laddning upp till 100%
- 6 Övervakning av laddningens bibehållande
- 7 Bibehållande av laddning (*)
- 8 Puls-återställning av laddning (*)

(*) Faser för bibehållande efter avslutad laddning.

De avbryts när batteriladdaren har kopplats bort.

6 AVSLUTAD LADDNING - EXEMPEL



Avslutad laddning Pulse-Tronic - Positivt resultat

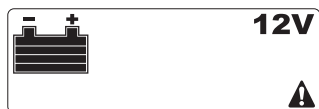

Avslutad laddning Pulse-Tronic - Negativt resultat

B TEST

LADDNINGSTILLSTÅND 

1 VÄLJA SPÄNNING



2 VÄLJA TEST

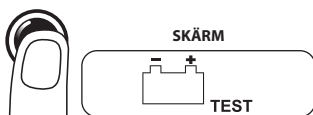

3 ANSLUTA KLÄMMORNA

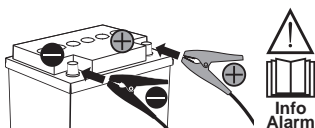

4 AVSLUTAT TEST - EXEMPEL



SKÄRMFÖRKLARING



B TEST

BATTERIETS
STARTKAPACITET 

1 VÄLJA SPÄNNING



2 VÄLJA TEST

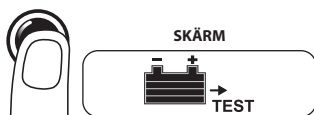

3 ANSLUTA KLÄMMORNA

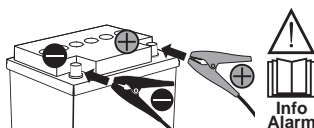

4 STARTA FORDONET



5 AVSLUTAT TEST - EXEMPEL



SKÄRMFÖRKLARING



B TEST

GENERATOR



1 VÄLJA SPÄNNING



SKÄRM

12V



Info Alarm

2 VÄLJA TEST



SKÄRM



TEST

3 ANSLUTA KLÄMMORNA

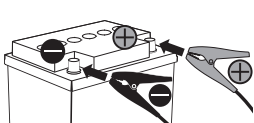

Info Alarm

4 STARTA FORDONET



5 AVSLUTAT TEST - EXEMPEL

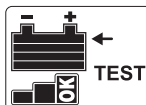

TEST

SKÄRMFÖRKLARING



positiv



tillräcklig



negativ

C UNDERHÅLL

RECOVERY



1 VÄLJA SPÄNNING



SKÄRM

12V



Info Alarm

2 VÄLJA AVANCERAD MENY



SKÄRM



3"

3 ANSLUTA KLÄMMORNA

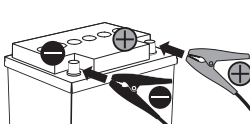

Info Alarm

4 AVSLUTAD PROCESS - EXEMPEL



5 LÄMNA FUNKTIONEN



3"

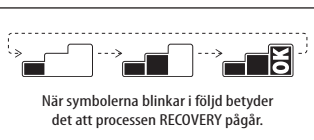

När symbolerna blinkar i följd betyder det att processen RECOVERY pågår.

D STRÖMFÖRSÖRJNING



INFORMATION
OM LARM



SUPPLY SUPPLY

BYTE AV
BATTERI

1 VÄLJA SPÄNNING



SKÄRM

12V



Info
Alarm

2 VÄLJA AVANCERAD MENY



SKÄRM

SUPPLY

3"

3 ANSLUTA KLÄMMORNA TILL FORDONETS BATTERIKABLAR

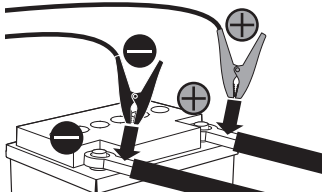

4 FORDON MED STRÖMFÖRSÖRJNING



TA BORT
BATTERIET



BYTA UT
BATTERIET

5 LÄMNA FUNKTIONEN



3"



KORTSLUTNING

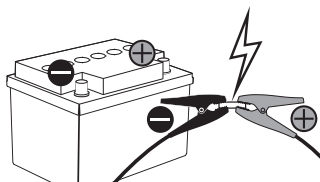

OMVÄND POLARITET

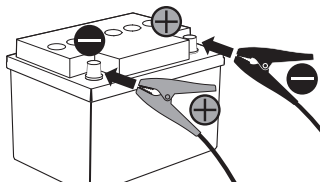

12V

12V

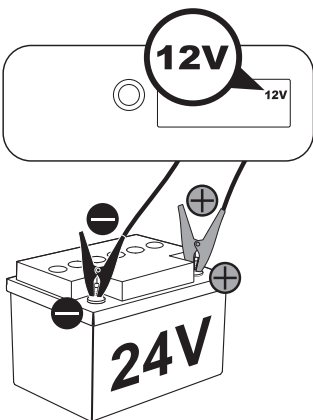

24V

LED-version

A LADDNING/ BIBEHÅLLANDE

PULSE-TRONIC TECHNOLOGY



1 VÄLJA SPÄNNING

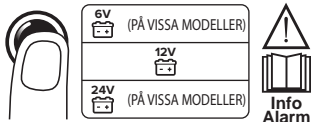

2 TILLVAL: VÄLJA AVANCERAD MENY



3 ANSLUTA KLÄMMORNA

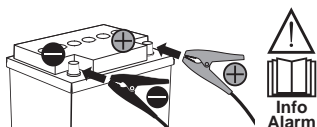

4 AVSLUTAD LADDNING - EXEMPEL



Avslutad laddning Pulse-Tronic - Positivt resultat



Avslutad laddning Pulse-Tronic - Negativt resultat

C UNDERHÅLL

RECOVERY



1 VÄLJA SPÄNNING

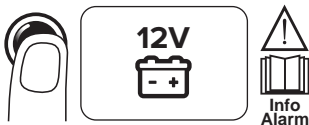

2 VÄLJA AVANCERAD MENY



3 ANSLUTA KLÄMMORNA

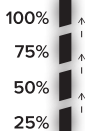
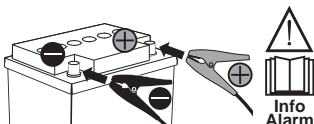

När lysdioderna blinkar i följd betyder det att processen RECOVERY pågår.

4 AVSLUTAD PROCESS - EXEMPEL



5 LÄMNA FUNKTIONEN



D STRÖMFÖRSÖRJNING



INFORMATION
OM LARM



SUPPLY SUPPLY

BYTE AV
BATTERI

1 VÄLJA SPÄNNING



12V



Info
Alarm

2 VÄLJA AVANCERAD MENY



3"



SUPPLY

3 ANSLUTA KLÄMMORNA TILL FORDONETS BATTERIKABLAR

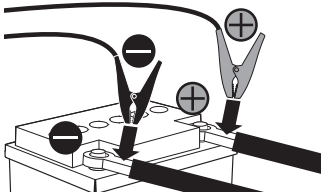

4 FORDON MED STRÖMFÖRSÖRJNING



TA BORT
BATTERIET



BYTA UT
BATTERIET

5 LÄMNA FUNKTIONEN



3"



KORTSLUTNING

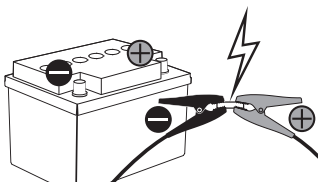

OMVÄND POLARITET

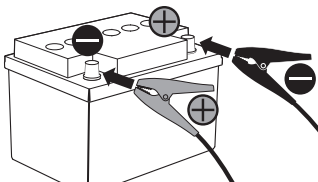

12V

12V



24V

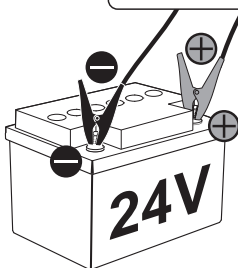

Verze LCD (str. 2)

- Úroveň nabití akumulátoru.
- Volba typu akumulátoru:
 - GEL:** olověné-vápenaté (PbCa) akumulátory s pevným želatinovým elektrolytem, úplně hermeticky uzavřené. Jedná se o bezúdržbové akumulátory.
 - AGM (ABSORBENT GLASS MAT):** olověné akumulátory s elektrolytem absorbovaným ve skelných vláknech. Úplně hermeticky uzavřené. Jedná se o bezúdržbové akumulátory.
 - AGM+:** zajišťují vyšší počet startovacích cyklů při vyšším proudu a větší hloubku vybití než standardní AGM. Používají se ve vozidlech, vybavených systémem Start-Stop. Vyznačují se omezenými rozměry, větší odolností vůči vibracím a rychlým dobitím.
 - Lithium (Li):** akumulátory s omezenou hmotností, vysokou energetickou hustotou a velmi nízkým samovybitím. Používají se zejména ve světě motoristického sportu.
 - EFB (Enhanced Flooded Battery):** akumulátory s tekutým elektrolytem a s lepší kapacitou nabíjení, které snášejí vyšší počet cyklů (startování) než klasické akumulátory. Jsou ideální pro vozidla, vybavená systémem Start-Stop.
- Nabíjení při nízkých teplotách (vhodné také pro akumulátory WET).
- Nastavené napětí akumulátoru.
- Režim RECOVERY.
Přídavná funkce, která slouží k obnovení akumulátorů, v nichž došlo k vytvoření síranu.
- Všeobecný alarm, upozorňující na záměnu polarit, zkrat, opotřeбенý nebo vadný akumulátor.
- Režim SUPPLY.
Režim SUPPLY napětového generátoru.
Režim nechráněný před záměnou polarit, zkratem a chybnou volbou napětí.
- Fáze nabíjení PULSE-TRONIC.
- Režim BOOST.
Přídavná funkce pro rychlé nabíjení.
- Režim TEST.
- Test alternátoru a test startovací kapacity akumulátoru (CCA).
- Výsledek TESTU, RECOVERY a ukončení nabíjení.
- Tlačítko nastavení:
 - NABÍJENÍ PULSE-TRONIC (GEL, AGM, AGM +, Li, EFB a nízké teploty ❄).
 - TEST (stav akumulátoru, startovací kapacita akumulátoru, alternátor vozidla).
 - Pokročilé programy: BOOST, RECOVERY, SUPPLY.

Verze LED (str. 2)

- Tlačítko nastavení:
Volba nabíjecího napětí a pokročilé programy.
- Nastavené napětí akumulátoru.
- Úroveň nabití akumulátoru:
 - LED 25 %:** probíhající nabíjení...
 - LED 50 %:** probíhající nabíjení...
 - LED 75 %:** probíhající nabíjení...
 - LED 100 %:** ukončení nabíjení.
- Pokročilé programy: **AGM ❄, RECOVERY, SUPPLY:**

- AGM ❄**
Funkce užitečná pro nabíjení akumulátoru typu „AGM“ nebo „WET“: olověné, hermeticky uzavřené akumulátory s elektrolytem na absorpčním materiálu nebo pro nabíjení obecného akumulátoru při základních teplotních podmínkách, pod 0 °C - ❄.
 - RECOVERY**
Přídavná funkce, která slouží k obnovení akumulátorů, v nichž došlo k vytvoření síranu.
 - SUPPLY**
Režim SUPPLY napětového generátoru
Režim nechráněný před záměnou polarit, zkratem a chybnou volbou napětí.
- Všeobecný alarm, upozorňující na záměnu polarit, zkrat, opotřeбенý nebo vadný akumulátor.

FUNKCE

- NABÍJENÍ PULSE-TRONIC
- TEST (je-li součástí)
 - TEST STAVU NABITÍ
 - TEST STARTOVACÍ KAPACITY AKUMULÁTORU (CCA)
 - TEST ALTERNÁTORU
- ÚDRŽBA AKUMULÁTORŮ
 - RECOVERY
- NAPÁJENÍ
 - SUPPLY (je-li součástí)

INFORMACE O ALARMECH

PŘIPOJENÍ NABÍJECÍCH KABELŮ

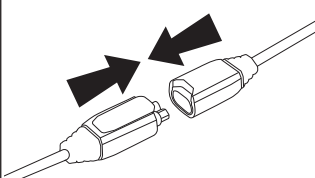

ZAPNUTÍ

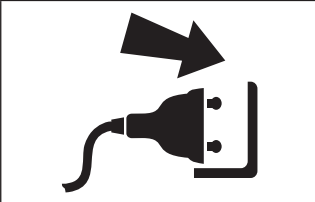

VYPNUTÍ

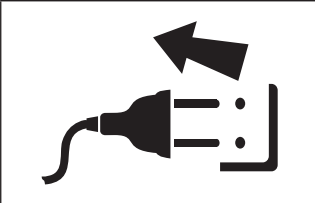

A NABÍJENÍ/UDRŽOVÁNÍ

PULSE-TRONIC TECHNOLOGY



1 VOLBA NAPĚTÍ

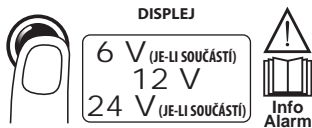

2 VOLBA PROCESU Pulse-Tronic



3 VOLITELNÁ FUNKCE: VOLBA POKROČILÉ NABÍDKY



Volitelná funkce pro rychlejší nabíjení

4 PŘIPOJENÍ KLEŠTÍ

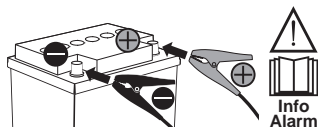

5 GRAF FÁZÍ NABÍJENÍ PULSE-TRONIC

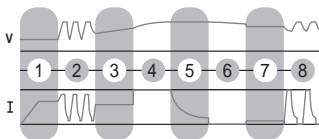

- 1 Test akumulátoru
- 2 Impulzní obnovení akumulátorů, v nichž došlo k vytvoření síranu / velmi vybitých akumulátorů
- 3 Kontrola neporušenosti
- 4 Nabití až na 80 %
- 5 Nabití až na 100 %
- 6 Monitorování udržování nabití
- 7 Udržování nabití (*)
- 8 Impulzní obnovení nabití (*)

(*) Fáze udržování po ukončení nabíjení. Jejich přerušení proběhne po odpojení nabíječky akumulátorů.

6 UKONČENÍ NABÍJENÍ - PŘÍKLAD



Ukončení nabíjení Pulse-Tronic - kladný výsledek



Ukončení nabíjení Pulse-Tronic - záporný výsledek

B TEST

STAV NABITÍ



1 VOLBA NAPĚTÍ



DISPLEJ

12V



2 VOLBA TESTU



DISPLEJ



TEST

3 PŘIPOJENÍ KLEŠTÍ

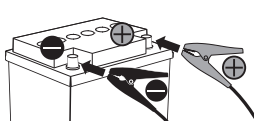

4 UKONČENÍ TESTU - PŘÍKLAD



TEST

12V

VYSVĚTLIVKY K DISPLEJI



velmi vybitý



vybitý



nabíjí

B TEST

STARTOVACÍ KAPACITA AKUMUÁTORU



1 VOLBA NAPĚTÍ



DISPLEJ

12V



2 VOLBA TESTU



DISPLEJ



TEST

3 PŘIPOJENÍ KLEŠTÍ

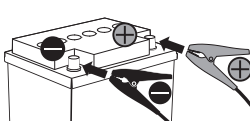

4 STARTOVÁNÍ VOZIDLA



5 UKONČENÍ TESTU - PŘÍKLAD



TEST

VYSVĚTLIVKY K DISPLEJI



kladný



dostatečný



záporný

B TEST

ALTERNÁTOR



1 VOLBA NAPĚTÍ



DISPLEJ

12V



2 VOLBA TESTU



DISPLEJ



TEST

3 PŘIPOJENÍ KLEŠTÍ

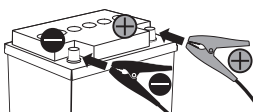

4 STARTOVÁNÍ VOZIDLA



5 UKONČENÍ TESTU - PŘÍKLAD

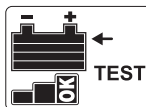

VYSVĚTLIVKY K DISPLEJI



kladný



dostatečný



záporný

C ÚDRŽBA

RECOVERY



1 VOLBA NAPĚTÍ



DISPLEJ

12V



2 VOLBA POKROČILÉ NABÍDKY



DISPLEJ

3"



3 PŘIPOJENÍ KLEŠTÍ

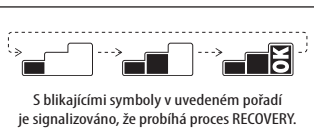
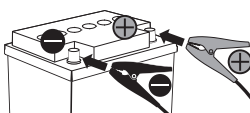

4 UKONČENÍ PROCESU - PŘÍKLAD



5 UKONČENÍ ZOBRAZOVÁNÍ FUNKCE



3"

D NAPÁJENÍ

SUPPLY

SUPPLY

VÝMĚNA
AKUMULÁTORU

1 VOLBA NAPĚTÍ



DISPLEJ

12V



Info
Alarm

2 VOLBA POKROČILÉ NABÍDKY



DISPLEJ

SUPPLY

3"

3 PŘIPOJENÍ KLEŠTÍ KE KABELŮM AKUMULÁTORU VOZIDLA

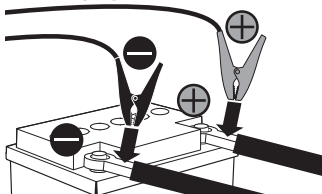

4 NAPÁJENÉ VOZIDLO

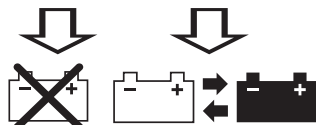

ODSTRANĚNÍ
AKUMULÁTORU

VÝMĚNA
AKUMULÁTORU

5 UKONČENÍ ZOBRAZOVÁNÍ FUNKCE



3"



INFORMACE O
ALARMECH



Info
Alarm



ZKRAT

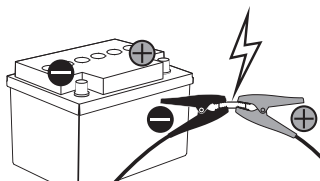

ZÁMĚNA POLARITY

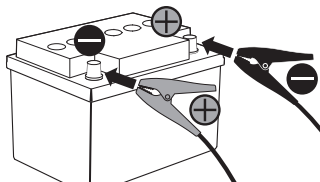

12V

12V

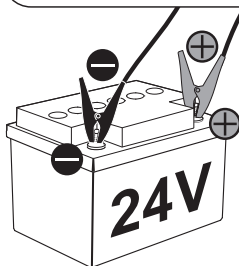

24V

Verze LED

A NABÍJENÍ/ UDRŽOVÁNÍ

PULSE-TRONIC TECHNOLOGY



1 VOLBA NAPĚTÍ

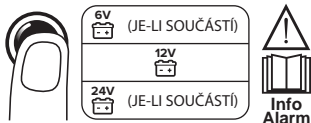

2 VOLITELNÁ FUNKCE: VOLBA POKROČILÉ NABÍDKY



3 PŘIPOJENÍ KLEŠTÍ

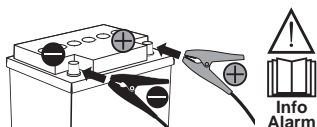

4 UKONČENÍ NABÍJENÍ - PŘÍKLAD



Ukončení nabíjení Pulse-Tronic - kladný výsledek



Ukončení nabíjení Pulse-Tronic - záporný výsledek

C ÚDRŽBA

RECOVERY



1 VOLBA NAPĚTÍ

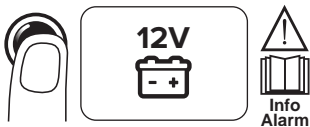

2 VOLBA POKROČILÉ NABÍDKY



3 PŘIPOJENÍ KLEŠTÍ

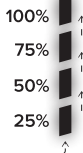
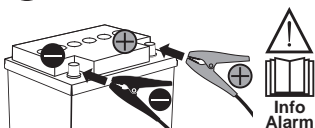

Postupně blikajícími LED je signalizováno, že probíhá proces RECOVERY.

4 UKONČENÍ PROCESU - PŘÍKLAD



5 UKONČENÍ ZOBRAZOVÁNÍ FUNKCE



D NAPÁJENÍ

SUPPLY

SUPPLY

VÝMĚNA
AKUMULÁTORU

1 VOLBA NAPĚTÍ



12V



Info
Alarm

2 VOLBA POKROČILÉ NABÍDKY



3"



SUPPLY

3 PŘIPOJENÍ KLEŠTÍ KE KABELŮM AKUMULÁTORU VOZIDLA

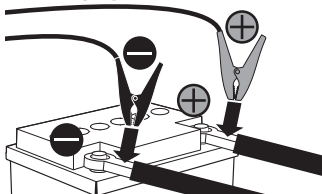

4 NAPÁJENÉ VOZIDLO



ODSTRANĚNÍ
AKUMULÁTORU

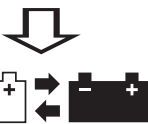

VÝMĚNA
AKUMULÁTORU

5 UKONČENÍ ZOBRAZOVÁNÍ FUNKCE



3"



INFORMACE O
ALARMECH



Info
Alarm



ZKRAT

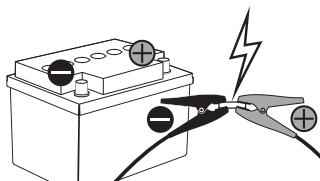

ZÁMĚNA POLARITY

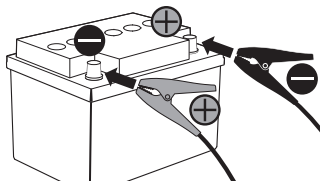

12V

12V



24V

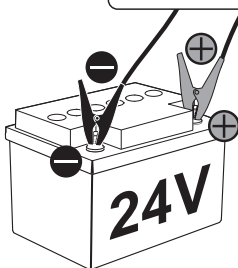

LCD verzija (str. 2)

- Razina napunjenosti akumulatora.
- Odabir tipa akumulatora:
 - GEL:** akumulatori na bazi olova i kalcija (PbCa) sa čvrstim elektrolitom želatinoznoga tipa, hermetički zatvoreni. Radi se o akumulatorima koje ne treba održavati.
 - AGM (ABSORBENT GLASS MAT):** olovni akumulatori s elektrolitom apsorbiranim u staklenom vlaknu. Hermetički zatvoreni. Radi se o akumulatorima koje ne treba održavati.
 - AGM+:** garantiraju veći broj pokretanja pri većoj struji i pri većoj razini pražnjenja u odnosu na standardne AGM akumulatore. Koriste se na vozilima opremljenim Start-Stop sustavima. Manje dimenzije, veća otpornost na vibracije i brzo punjenje.
 - Litij (Li):** akumulatori manje težine, s visokom energetsom gustoćom i iznimno niskim stupnjem samopražnjenja. Uglavnom se koriste u svijetu motosporta.
 - EFB (Enhanced Flooded Battery):** akumulatori s tekućim elektrolitom s većom sposobnošću punjenja i koji podnose veći broj ciklusa (pokretanja) u odnosu na tradicionalne akumulatore. Idealni za vozila opremljena Start-Stop sustavima.
- Punjenje na niskim temperaturama (pogodna i za WET akumulatore).
- Postavljeni napon akumulatora.
- Režim RECOVERY.
Dodatna funkcija za regeneraciju sulfatiranih akumulatora.
- Opći alarm zbog inverzije polova, kratkog spoja, dotrajalog ili pokvarenog akumulatora.
- Način rada SUPPLY.
Režim SUPPLY generatora napona.
Režim nije zaštićen od promjene polova, kratkog spoja i pogrešnog odabira napona.
- Faze punjenja PULSE-TRONIC.
- Način rada BOOST.
Dodatna funkcija za brzo punjenje.
- Način rada TEST.
- Testiranje alternatora i testiranje kapaciteta pokretanja koji ima akumulator (CCA).
- Ishod testiranja, RECOVERY i kraja punjenja.
- Tipka za postavke:
 - PUNJENJE PULSE-TRONIC (GEL, AGM, AGM+, Li, EFB i niske temperature ❄).
 - TEST (stanje akumulatora, kapacitet pokretanja koji ima akumulator, alternator vozila).
 - Unaprijedjeni programi: BOOST, RECOVERY, SUPPLY.

LED verzija (str. 2)

- Tipka za postavke:
Odabir napona punjenja i unaprijedjenih programa.
- Postavljeni napon akumulatora.
- Razina napunjenosti akumulatora:
Led 25%: punjenje u tijeku.
Led 50%: punjenje u tijeku.
Led 75%: punjenje u tijeku.
Led 100%: kraj punjenja.
- Unaprijedjeni programi: **AGM** ❄, **RECOVERY, SUPPLY:**

• AGM ❄

Funkcija korisna za punjenje akumulatora tipa „AGM” ili „WET”: olovni akumulatori hermetički zatvoreni, s elektrolitima na upijajućem materijalu ili pak za punjenje običnog akumulatora u uvjetima niske temperature, ispod 0°C ❄.

• RECOVERY

Dodatna funkcija za regeneraciju sulfatiranih akumulatora.

• SUPPLY

Režim SUPPLY generatora napona

Režim nije zaštićen od promjene polova, kratkog spoja i pogrešnog odabira napona.

- Opći alarm zbog inverzije polova, kratkog spoja, dotrajalog ili pokvarenog akumulatora.

FUNKCIJE

- PUNJENJE PULSE-TRONIC
- TEST (ako je predviđeno)
 - TESTIRANJE STANJA NAPUNJENOSTI
 - TESTIRANJE KAPACITETA POKRETANJA KOJI IMA AKUMULATOR (CCA)
 - TESTIRANJE ALTERNATORA
- ODRŽAVANJE AKUMULATORA
 - RECOVERY
- NAPAJANJE
 - SUPPLY (ako je predviđeno)

INFO O ALARMIMA

SPAJANJE KABELA ZA PUNJENJE

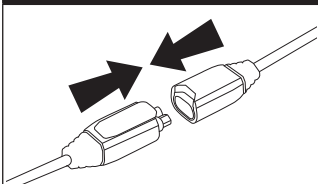

PALJENJE



GAŠENJE

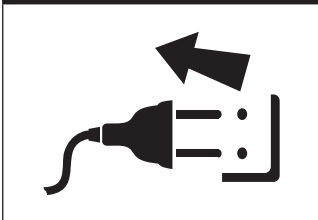

A PUNJENJE/ODRŽAVANJE

**PULSE-TRONIC
TEHNOLOGIJA**

- + - + - + - + - + - +
GEL AGM AGM+ Li EFB WET

1 ODABIR NAPONA



2 ODABIR PROCESA Pulse-Tronic



3 OPCIJA: ODABIR NAPREDNOG IZBORNIKA



Opcija za brže punjenje

4 SPAJANJE KLIJEŠTA

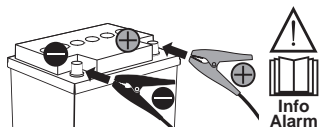

5 GRAFIKON FAZA PUNJENJA PULSE-TRONIC

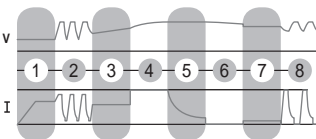

- 1 Testiranje akumulatora
- 2 Ponovno osposobljavanje sulfatiranih / iznimno praznih akumulatora
- 3 Provjera integriteta
- 4 Punjenje do 80%
- 5 Punjenje do 100%
- 6 Praćenje održivosti punjenja
- 7 Održavanje punjenja (*)
- 8 Ponovno uspostavljanje impulsnog punjenja (*)

(*) Faze održavanja nakon završetka punjenja. Do njihovog prekida dolazi kada iskopčate punjač akumulatora.

6 KRAJ PUNJENJA - PRIMJER



Kraj punjenja Pulse-Tronic - Pozitivni rezultat



Kraj punjenja Pulse-Tronic - Negativni rezultat

B TESTIRANJE

STANJE NAPUNJENOSTI



1 ODABIR NAPONA



ZASLON

12V



2 ODABIR TESTIRANJA



ZASLON



TEST

3 SPAJANJE KLIJEŠTA

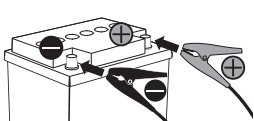

4 KRAJ TESTIRANJA - PRIMJER



TEST

12V

LEGENDA ZASLON



iznimno prazan



prazan



pun

B TESTIRANJE

KAPACITET POKRETANJA KOJI IMA AKUMULATOR



1 ODABIR NAPONA



ZASLON

12V



2 ODABIR TESTIRANJA



ZASLON



TEST

3 SPAJANJE KLIJEŠTA

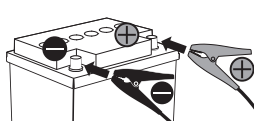

4 POKRETANJE VOZILA



5 KRAJ TESTIRANJA - PRIMJER



TEST

LEGENDA ZASLON



pozitivan



dovoljno



negativan

B TESTIRANJE

ALTERNATOR



1 ODABIR NAPONA



ZASLON

12V



2 ODABIR TESTIRANJA



ZASLON



TEST

3 SPAJANJE KLIJEŠTA

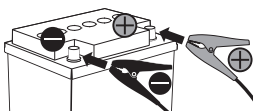

4 POKRETANJE VOZILA



5 KRAJ TESTIRANJA - PRIMJER



LEGENDA ZASLON



pozitivan



dovoljno



negativan

C ODRŽAVANJE

RECOVERY



1 ODABIR NAPONA



ZASLON

12V



2 ODABIR NAPREDNOG IZBORNIKA



ZASLON



3"

3 SPAJANJE KLIJEŠTA

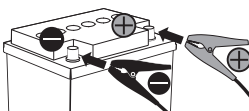

4 KRAJ PROCESA - PRIMJER



5 IZLAZ IZ FUNKCIJE



3"

D NAPAJANJE

SUPPLY

SUPPLY

PROMJENA
AKUMULATORA

1 ODABIR NAPONA



ZASLON

12V



Info
Alarm

2 ODABIR NAPREDNOG IZBORNIKA



ZASLON

SUPPLY

3"

3 SPAJANJE KLIJEŠTA NA KABELE AKUMULATORA VOZILA

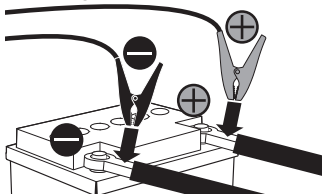

4 VOZILO SE NAPAJA

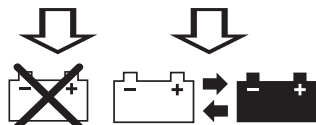

SKIDANJE
AKUMULATOR

ZAMJENA
AKUMULATOR

5 IZLAZ IZ FUNKCIJE



3"



INFO O
ALARMIMA  Info
Alarm



KRATAK SPOJ

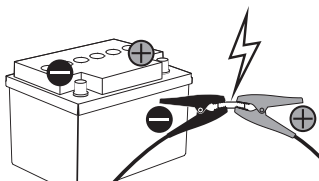

INVERZIJA POLOVA

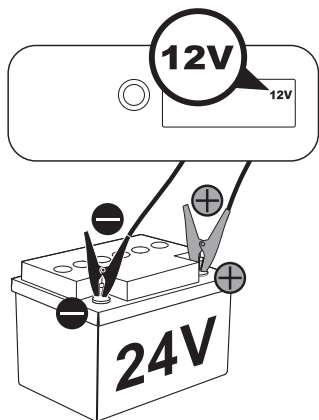
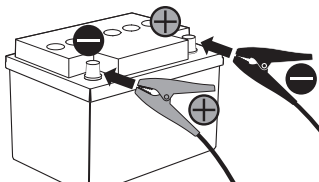

LED verzija

A

PUNJENJE/ ODRŽAVANJE

PULSE-TRONIC TEHNOLOGIJA



1 ODABIR NAPONA

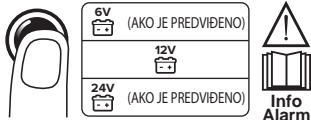

2 OPCIJA: ODABIR NAPREDNOG IZBORNIKA



3 SPAJANJE KLIJEŠTA

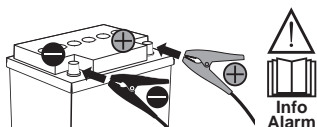

4 KRAJ PUNJENJA - PRIMJER



Kraj punjenja Pulse-Tronic - Pozitivni rezultat



Kraj punjenja Pulse-Tronic - Negativni rezultat

C

ODRŽAVANJE

RECOVERY



1 ODABIR NAPONA

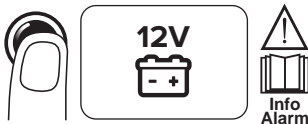

2 ODABIR NAPREDNOG IZBORNIKA



3 SPAJANJE KLIJEŠTA

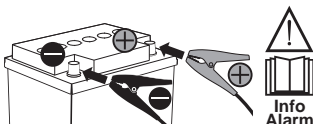

Kada led svjetla trepere jedna za drugim to označava da je proces RECOVERY u tijeku.

4 KRAJ PROCESA - PRIMJER



5 IZLAZ IZ FUNKCIJE



D NAPAJANJE

SUPPLY

SUPPLY

PROMJENA
AKUMULATORA

1 ODABIR NAPONA



12V



Info
Alarm

2 ODABIR NAPREDNOG IZBORNIKA



3''

SUPPLY

3 SPAJANJE KLIJEŠTA NA KABELE AKUMULATORA VOZILA

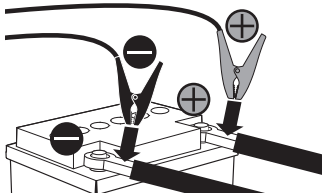

4 VOZILO SE NAPAJA



SKIDANJE
AKUMULATOR



ZAMJENA
AKUMULATOR

5 IZLAZ IZ FUNKCIJE



3''



INFO O
ALARMIMA



Info
Alarm



KRATAK SPOJ

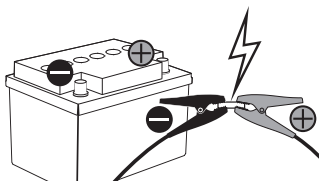

INVERZIJA POLOVA

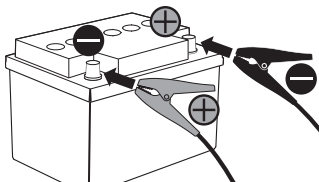

12V

12V



24V

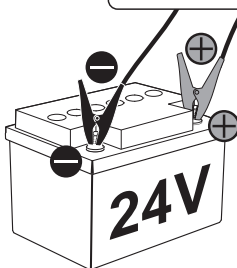

Wersja LCD (str. 2)

1. Stan naładowania akumulatora.
2. Wybór typologii akumulatora:
 - **GEL**: akumulatory Ołowiowo-Wapniowe (PbCa) z elektrolitem stałym w postaci żelu, całkowicie zaplombowane. Są akumulatorami nie wymagającymi konserwacji.
 - **AGM** (ABSORBENT GLASS MAT): akumulatory ołowiowe z elektrolitem uwieczonym w separatorach z włókna szklanego. Całkowicie zaplombowane. Są akumulatorami nie wymagającymi konserwacji.
 - **AGM+**: zapewniają większą liczbę rozruchów przy wyższej wartości prądu i większym rozładowaniu od standardowych akumulatorów AGM. Używane w pojazdach wyposażonych w system Start-Stop. Zredukowane wymiary, większa odporność na wibracje i krótszy czas ładowania.
 - **Litowe (Li)**: akumulatory o niskiej wadze, dużej gęstości energetycznej i bardzo niskim samorozładowaniu. Są używane głównie w branży sportów motorowych.
 - **EFB** (Enhanced Flooded Battery): akumulatory z ciekłym elektrolitem o większej zdolności ładowania, obsługujące większą liczbę cykli (rozruchów) w stosunku do akumulatorów tradycyjnych. Idealne dla pojazdów wyposażonych w system Start-Stop.
3. Ładowanie w niskich temperaturach (zalecane również dla baterii WET).
4. Ustawione napięcie akumulatora.
5. Tryb RECOVERY.
Funkcja dodatkowa umożliwiająca odzysk akumulatorów zasiarczonych.
6. Zwykły alarm sygnalizujący odwróconą polaryzację, zwarcie, zużyty lub uszkodzony akumulator.
7. Tryb SUPPLY.
Tryb SUPPLY generatora napięcia.
Tryb niezabezpieczony przed odwrótną polaryzacją, zwarciem i nieprawidłowym wyborem napięcia.
8. Fazy ładowania PULSE-TRONIC.
9. Tryb BOOST.
Funkcja dodatkowa dla szybkiego ładowania.
10. Tryb TEST.
11. Test alternatora i Test zdolności uruchamiania akumulatora (CCA).
12. Wyniki TEST, RECOVERY i koniec ładowania.
13. Przycisk ustawiania:
 - ŁADOWANIE PULSE-TRONIC (GEL, AGM, AGM +, Li, EFB i niskie temperatury ❄).
 - TEST (stan akumulatora, zdolność uruchamiania akumulatora, alternator pojazdu).
 - Programy zaawansowane: BOOST, RECOVERY, SUPPLY.

Wersja LED (str. 2)

1. Przycisk ustawiania:
Wybór napięcia ładowania i programów zaawansowanych.
2. Ustawione napięcie akumulatora.
3. Poziom naładowania akumulatora:
Led 25% : ładowanie w toku.
Led 50% : ładowanie w toku.
Led 75% : ładowanie w toku.
Led 100% : koniec ładowania.
4. Programy zaawansowane: **AGM** ❄.

RECOVERY, SUPPLY:

• **AGM** ❄

Funkcja użyteczna w przypadku ładowania akumulatorów typu „AGM” lub „WET”: akumulatory ołowiowe, zaplombowane, z elektrolitem na materiale absorbującym lub w przypadku ładowania zwykłych akumulatorów w warunkach niskiej temperatury, poniżej 0°C ❄.

• **RECOVERY**

Funkcja dodatkowa umożliwiająca odzysk akumulatorów zasiarczonych.

• **SUPPLY**

Tryb SUPPLY generatora napięcia

Tryb niezabezpieczony przed odwrótną polaryzacją, zwarciem i nieprawidłowym wyborem napięcia.

5. Zwykły alarm sygnalizujący odwróconą polaryzację, zwarcie, zużyty lub uszkodzony akumulator.

FUNKCJE

- A. ŁADOWANIE PULSE-TRONIC
- B. TEST (gdzie przewidziany)
 - TEST STANU NAŁADOWANIA
 - TEST ZDOLNOŚCI URUCHAMIANIA AKUMULATORA (CCA)
 - TEST ALTERNATORA
- C. KONSERWACJA AKUMULATORÓW
 - RECOVERY
- D. ZASILANIE
 - SUPPLY (gdzie przewidziany)

INFORMACJE O ALARMACH

PODŁĄCZENIE KABLI DO ŁADOWANIA

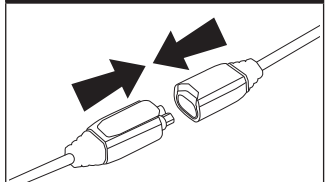

WŁĄCZANIE

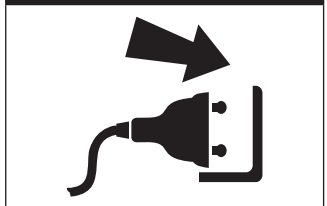

WYŁĄCZANIE

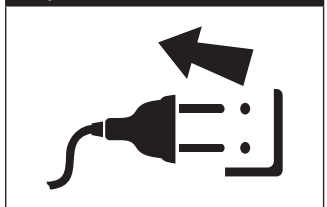

A ŁADOWANIE/PODTRZYMYWANIE

PULSE-TRONIC TECHNOLOGY



1 WYBÓR NAPIĘCIA



2 WYBÓR PROCESU Pulse-Tronic



3 OPCJONALNE: WYBÓR MENU ZAAWANSOWANEGO



Opcjonalne dla szybszego ładowania

4 PODŁĄCZENIE KLESZCZY

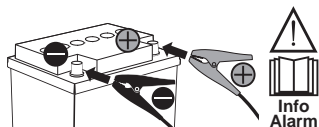

5 WYKRES FAZ ŁADOWANIA PULSE-TRONIC

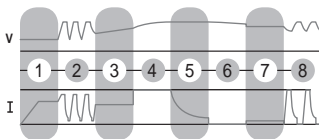

- 1 Test akumulatora
- 2 Odzysk w trybie impulsowym akumulatorów zasiarczonych/bardzo rozładowanych
- 3 Kontrola stanu
- 4 Ładowanie do 80%
- 5 Ładowanie do 100%
- 6 Monitorowanie utrzymywania naładowania
- 7 Utrzymywanie naładowania (*)
- 8 Przywracanie naładowania w trybie impulsowym (*)

(*) Fazy konserwacji po zakończeniu ładowania. Ich przerwanie następuje po odłączeniu prostownika.

6 KONIEC ŁADOWANIA - PRZYKŁAD



Koniec ładowania Pulse-Tronic - Wynik pozytywny



Koniec ładowania Pulse-Tronic - Wynik negatywny

B TEST

STAN NAŁADOWANIA



1 WYBÓR NAPIĘCIA



WYŚWIETLACZ

12V



Info Alarm

2 USTAWIANIE TESTU



WYŚWIETLACZ



TEST

3 PODŁĄCZENIE KLESZCZY

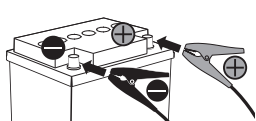

Info Alarm

4 KONIEC TESTU - PRZYKŁAD



TEST

12V

LEGENDA WYŚWIETLACZA



bardzo
rozładowany



rozładowany



naładowany

B TEST

ZDOLNOŚĆ URUCHAMIANIA AKUMULATORA



1 WYBÓR NAPIĘCIA



WYŚWIETLACZ

12V



Info Alarm

2 USTAWIANIE TESTU



WYŚWIETLACZ



TEST

3 PODŁĄCZENIE KLESZCZY

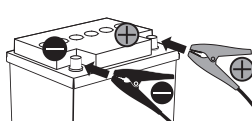

Info Alarm

4 ROZRUCH POJAZDU



5 KONIEC TESTU - PRZYKŁAD



TEST



dodatni



wystarczający



ujemny

B TEST

ALTERNATOR



1 WYBÓR NAPIĘCIA



WYŚWIETLACZ

12V



2 USTAWIANIE TESTU



WYŚWIETLACZ



TEST

3 PODŁĄCZENIE KLESZCZY

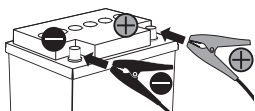

4 ROZRUCH POJAZDU



5 KONIEC TESTU - PRZYKŁAD

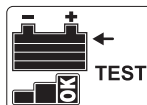

LEGENDA WYŚWIETLACZA



dodatni



wystarczający



ujemny

C KONSERWACJA

RECOVERY



1 WYBÓR NAPIĘCIA



WYŚWIETLACZ

12V



2 WYBÓR MENU ZAAWANSOWANEGO



WYŚWIETLACZ



3"

3 PODŁĄCZENIE KLESZCZY

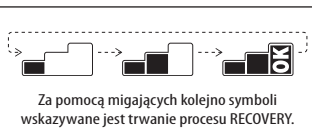
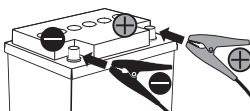

4 KONIEC PROCESU - PRZYKŁAD



5 WYJŚCIE Z FUNKCJI



3"

D ZASILANIE

SUPPLY SUPPLY

WYMIANA
AKUMULATOR

1 WYBÓR NAPIĘCIA



WYŚWIETLACZ

12V



2 WYBÓR MENU ZAAWANSOWANEGO



WYŚWIETLACZ

SUPPLY

3 POŁĄCZENIE KLESZCZY Z KABLAMI AKUMULATORA POJAZDU

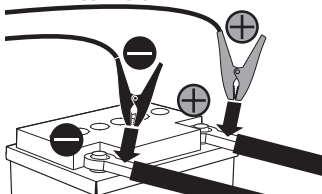

4 POJAZD ZASILANY



DEMONTAŻ
AKUMULATOR



WYMIANA
AKUMULATOR

5 WYJŚCIE Z FUNKCJI



3''



INFORMACJE O
ALARMACH



Info
Alarm



ZWARCIE

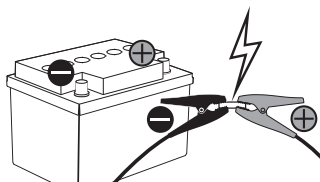

ODWROTNA POLARYZACJA

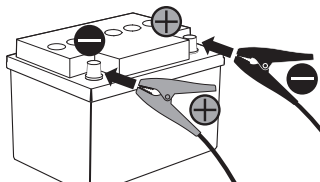

12V

12V

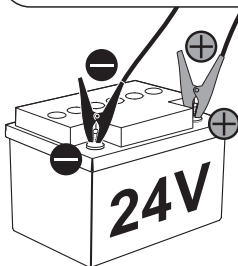

Wersja LED

A ŁADOWANIE/ UTRZYMYWANIE

PULSE-TRONIC TECHNOLOGY



1 WYBÓR NAPIĘCIA

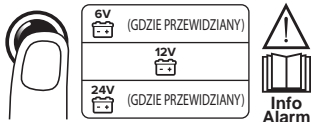

2 OPCJONALNE: WYBÓR MENU ZAAWANSOWANEGO



3 PODŁĄCZENIE KLESZCZY

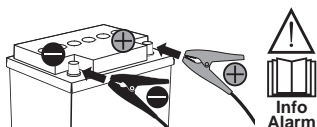

4 KONIEC ŁADOWANIA - PRZYKŁAD



Koniec ładowania Pulse-Tronic - Wynik pozytywny



Koniec ładowania Pulse-Tronic - Wynik negatywny

C KONSERWACJA

RECOVERY



1 WYBÓR NAPIĘCIA

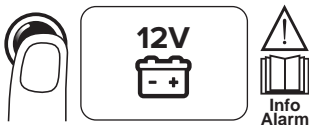

2 WYBÓR MENU ZAAWANSOWANEGO



3 PODŁĄCZENIE KLESZCZY

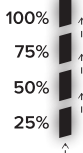
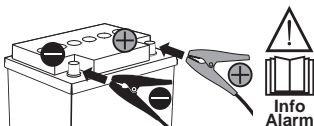

Za pomocą migających kolejno diod wskazywane jest trwanie procesu RECOVERY.

4 KONIEC PROCESU - PRZYKŁAD



5 WYJŚCIE Z FUNKCJI



D ZASILANIE

SUPPLY

SUPPLY

WYMIANA
AKUMULATOR

1 WYBÓR NAPIĘCIA



12V



Info
Alarm

2 WYBÓR MENU ZAAWANSOWANEGO



SUPPLY

3"

3 POŁĄCZENIE KLESZCZY Z KABLAMI AKUMULATORA POJAZDU

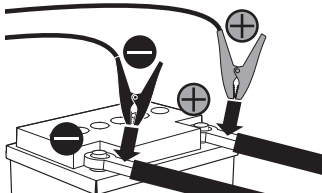

4 POJAZD ZASILANY



DEMONTAŻ
AKUMULATOR

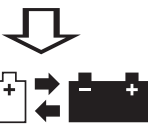

WYMIANA
AKUMULATOR

5 WYJŚCIE Z FUNKCJI



3"



INFORMACJE
O ALARMACH



Info
Alarm



ZWARCIE

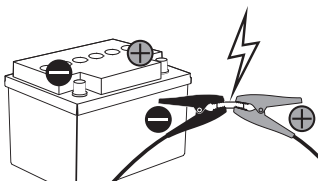

ODWROTNA POLARYZACJA

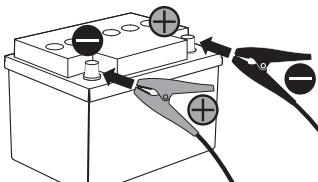

12V

12V



24V

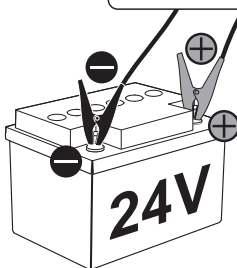

LCD-versio (sivu 2)

- Akun lataustaso.
- Akkutyypin valinta:
 - **GEELI:** Lyijy-kalsiumakut (PbCa), joissa on kiinteä elektrolyytti gelatiinityyppi, täysin suljettu. Ne ovat huoltovapaita akkuja.
 - **AGM (ABSORBENT GLASS MAT):** Lyijyakut absorboituneella elektrolyytillä lasikuitua. Täysin suljettu. Ne ovat huoltovapaita akkuja.
 - **AGM+:** ne varmistavat suuremman määrän käynnistyksiä suuremmalla virralla ja suuremman purkausvyydyden AGM-standardiakkuihin nähden. Käytetään ajoneuvoissa joissa Start-Stop-järjestelmä. Pieni koko, suurempi tärinänkestävyys ja nopeat latausajat.
 - **Litium (Li):** akut, joiden paino on pieni, suuri energiatiheys ja erittäin pieni itsepurkautuminen. Niitä käytetään ensisijaisesti moottoriurheilumaailmassa.
 - **EFB (Enhanced Flooded Battery):** nestemäiset elektrolyyttiakut, joiden latauskapasiteetti on parempi ja jotka tukevat suurempaa jaksojen (käynnistysten) määrää kuin perinteiset. Ihanteelliset ajoneuvoille joissa Start-Stop-järjestelmä.
- Lataus alhaisissa lämpötiloissa (sopii myös WET-akkuihin).
- Asetettu akun jännite.
- Toimintatapa RECOVERY.

Lisätoiminto sulfonoitujen akkujen elvyttämiseksi.
- Yleinen hälytys napaisuuden käänteisyydelle, oikosulku, kulunut tai viallinen akku.
- Toimintatapa SUPPLY.

Toimintatapa SUPPLY jännitelähde.

Toimintatapaa ei suojattu käänteiseltä napaisuudelta tai jännitteen väärältä valinnalta.
- Latausvaiheet PULSE-TRONIC.
- Toimintatapa BOOST.

Lisätoiminto pikalatausta varten.
- Toimintatapa TEST.
- Vaihtovirtageneraattorin testi ja akun käynnistyskyvyn testi (CCA).
- TEST, RECOVERY ja latauksen lopun tulos.
- Asetuspainike:
 - PULSE-TRONIC-LATAUS (GEL, AGM, AGM +, Li, EFB ja alhaiset lämpötilat ❄️).
 - TEST (akun tila, akun käynnistyskapasiteetti, ajoneuvon vaihtovirtageneraattori).
 - Kehittyneet ohjelmat: BOOST, RECOVERY, SUPPLY.

LED-versio (sivu 2)

- Asetuspainike:

Latausjännitteen valinta ja kehittyneet ohjelmat.
- Asetettu akun jännite.
- Akun lataustaso:
 - Led 25 % :** lataus käynnissä.
 - Led 50 % :** lataus käynnissä.
 - Led 75 % :** lataus käynnissä.
 - Led 100 % :** lataus päätynyt.
- Kehittyneet ohjelmat: **AGM ❄️, RECOVERY, SUPPLY:**

- **AGM ❄️**
Hyödyllinen toiminto "AGM"- tai "WET"- tyyppisten akkujen lataamiseen: lyijyakut, tiivistetyt akut, akut elektrolyytillä absorboivalla materiaalilla tai yleisakun lataamiseen matalissa lämpötiloissa, alle 0 °C ❄️.
 - **RECOVERY**
Lisätoiminto sulfonoitujen akkujen elvyttämiseksi.
 - **SUPPLY**
Toimintatapa SUPPLY jännitelähde
Toimintatapaa ei suojattu käänteiseltä napaisuudelta tai jännitteen väärältä valinnalta.
- Yleinen hälytys napaisuuden käänteisyydelle, oikosulku, kulunut tai viallinen akku.

TOIMINNOT

- LATAUS PULSE-TRONIC
- TESTI (mikäli varusteena)
 - LATAUSTILAN TESTI
 - AKUN KÄYNNISTYSKYVYN TESTI (CCA)
 - VAIHTOVIRTAGENERAATTORIN TESTI
- AKKUJEN HUOLTO
 - RECOVERY
- VIRRANSYÖTTÖ
 - SUPPLY (mikäli varusteena)

HÄLYTYSTIEDOT

LATAUSKAAPELIEN LIITOS

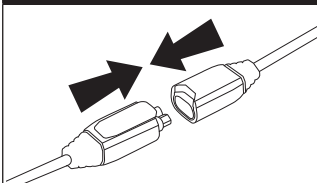

KÄYNNISTYS

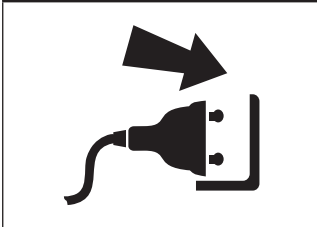

SAMMUTUS

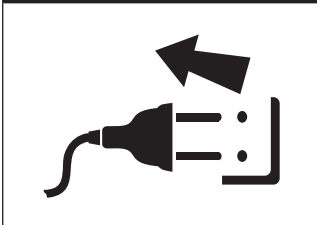

A LATAUS/YLLÄPITO

PULSE-TRONIC TECHNOLOGY



1 JÄNNITTEEN VALINTA



2 PROSESSIN VALINTA Pulse-Tronic



3 VALINNAINEN: KEHITTYNEEN VALIKON VALINTA



Valinnainen nopeampaa latausta varten

4 PIHTIEN LIITÄNTÄ

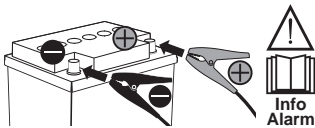

5 PULSE-TRONIC- LATAUSVAIHEIDEN KAAVIO

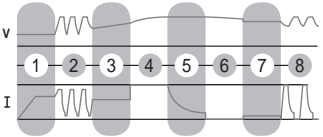

- 1 Akun testi
- 2 Impulssilatauksen/erittäin tyhjien akkujen palautus
- 3 Eheyden tarkastus
- 4 Lataus 80 %:in asti
- 5 Lataus 100 %:in asti
- 6 Latauksen pysyvyyden valvonta
- 7 Latauksen ylläpito (*)
- 8 Impulssilatauksen palautus (*)

(*) Ylläpitovaiheet latauksen päättymisen jälkeen.

Niiden keskeytys tapahtuu kun akkulaturi on kytketty irti.

6 LATAUKSEN LOPPU - ESIMERKKI



Latauksen loppu Pulse - Tronic - positiivinen tulos

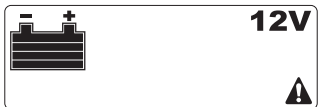

Latauksen loppu Pulse - Tronic - negatiivinen tulos

B TESTI

LATAUKSEN TILA



1 JÄNNITTEEN VALINTA



NÄYTTÖ

12V



2 TESTIN VALINTA



NÄYTTÖ



TEST

3 PIHTIEN LIITÄNTÄ

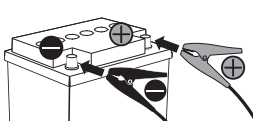

4 TESTIN LOPPU - ESIMERKKI



TEST

12V

NÄYTÖN SELITYKSET



erittäin tyhjä



tyhjä



ladattu

B TESTI

AKUN KÄYNNISTYSKAPASITEETTI



1 JÄNNITTEEN VALINTA



NÄYTTÖ

12V



2 TESTIN VALINTA



NÄYTTÖ



TEST

3 PIHTIEN LIITÄNTÄ

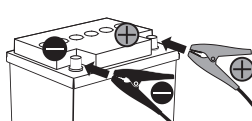

4 AJONEUVON KÄYNNISTYS



5 TESTIN LOPPU - ESIMERKKI



TEST

NÄYTÖN SELITYKSET



positiivinen



riittävä



negatiivinen

B TESTI

VAIHTOVIRTAGENERAATTORI 

1 JÄNNITTEEN VALINTA



2 TESTIN VALINTA

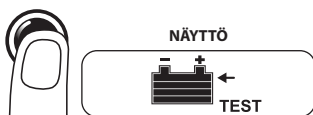

3 PIHTIEN LIITÄNTÄ

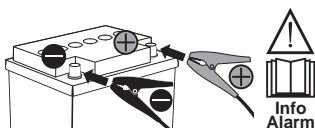

4 AJONEUVON KÄYNNISTYS



5 TESTIN LOPPU - ESIMERKKI



NÄYTÖN SELITYKSET



C HUOLTO

RECOVERY 

1 JÄNNITTEEN VALINTA



2 KEHITYNEEN VALIKON VALINTA



3 PIHTIEN LIITÄNTÄ

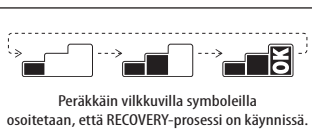
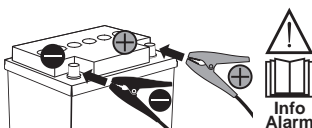

4 MENETELMÄN LOPPU - ESIMERKKI



5 POISTUMINEN TOIMINNOSTA



D VIRRANSYÖTTÖ

SUPPLY

SUPPLY

AKUN
VAIHTO

1 JÄNNITTEEN VALINTA



NÄYTTÖ

12V



Info
Alarm

2 KEHITTYNEEN VALIKON VALINTA



NÄYTTÖ

SUPPLY

3"

3 PIHTIEN LIITÄNTÄ AJONEUVON AKUN KAAPELEIHIN

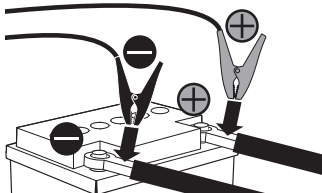

4 AJONEUVOSSA VIRTA

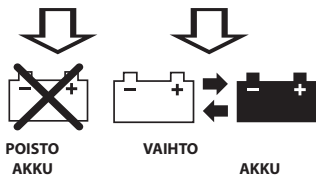

5 POISTUMINEN TOIMINNOSTA



3"



HÄLYTYSTIEDOT  Info
Alarm



OIKOSULKU

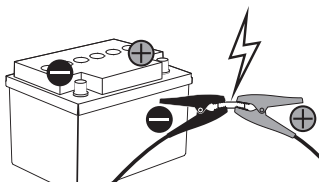

NAPAIKUUDEN KÄÄNTEISYYS

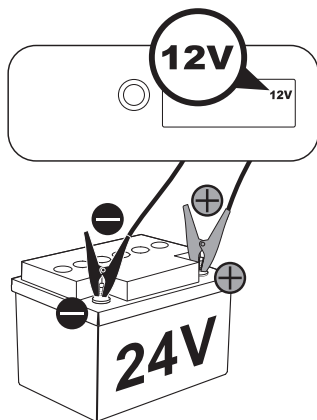
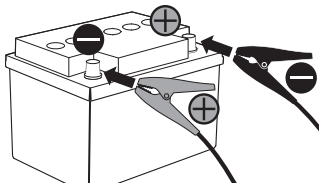

LED-versio

A LATAUS/ KUNNOSSAPITO

PULSE-TRONIC TECHNOLOGY



1 JÄNNITTEEN VALINTA

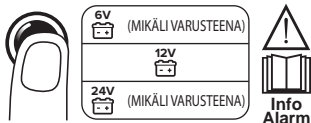

2 VALINNAINEN: KEHITYNEEN VALIKON VALINTA



3 PIHTIEN LIITÄNTÄ

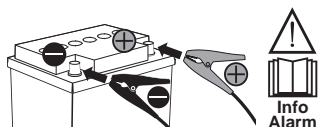

4 LATAUKSEN LOPPU - ESIMERKKI

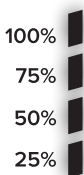

Latauksen loppu Pulse - Tronic - positiivinen tulos



Latauksen loppu Pulse - Tronic - negatiivinen tulos

C HUOLTO

RECOVERY



1 JÄNNITTEEN VALINTA

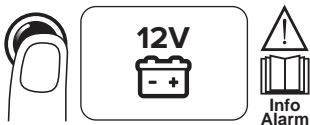

2 KEHITYNEEN VALIKON VALINTA



3 PIHTIEN LIITÄNTÄ

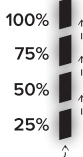
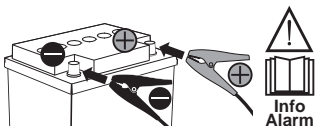

Peräkkäin vilkkuvilla led-
valoilla
osoitetaan,
että RECOVERY-
prosessi on
käynnissä.

4 MENETELMÄN LOPPU - ESIMERKKI



5 POISTUMINEN TOIMINNOSTA



D VIRRANSYÖTTÖ

SUPPLY

SUPPLY

AKUN
VAIHTO

1 JÄNNITTEEN VALINTA



12V



Info
Alarm

2 KEHITTYNEEN VALIKON VALINTA



3''

SUPPLY

3 PIHTIEN LIITÄNTÄ AJONEUVON AKUN KAAPELEIHIN

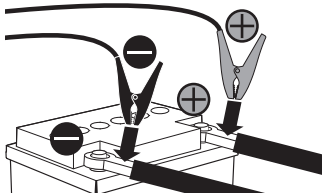

4 AJONEUVOSSA VIRTA



POISTO
AKKU



VAIHTO

AKKU

5 POISTUMINEN TOIMINNOSTA



3''



HÄLYTYSTIEDOT Info
Alarm



OIKOSULKU

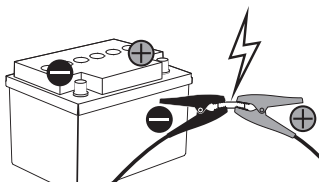

NAPAIKUUDEN KÄÄNTEISYYS

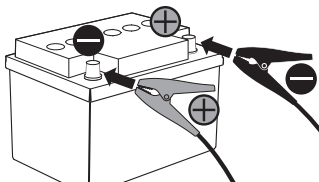

12V

12V



24V

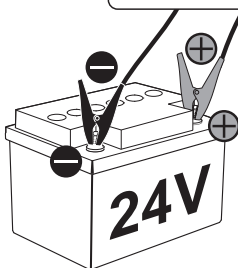

LCD-version (sd. 2)

- Batteriets opladningsniveau.
- Valg af batteritype:
 - **GEL:** Helt forseglede bly-calciumbatterier (PbCa) med fast elektrolyt af geléagtig type. Det drejer sig om vedligeholdelsesfrie batterier.
 - **AGM (ABSORBENT GLASS MAT):** Blybatteri med elektrolyt i absorptiv glasmåtte. Helt forseglede. Det drejer sig om vedligeholdelsesfrie batterier.
 - **AGM+:** sikrer et højere antal starter ved en højere strømstyrke samt en større afladningsdybde end AGM-standardbatterierne. Anvendes i køretøjer udstyret med start-stop-system. Mindre mål, højere modstandsdygtighed overfor vibrationer og hurtig genopladning.
 - **Litium (Li):** Lettere batterier, høj energitæthed og meget lav selvafladning. De anvendes først og fremmest i motorsporten.
 - **EFB (Enhanced Flooded Battery):** Batterier med flydende elektrolyt og en bedre ladeevne, der understøtter et større antal cyklusser (starter) end traditionelle batterier. Den ideelle løsning til køretøjer udstyret med start-stop-system.
- Oplader ved lave temperaturer (også egnet til WET-batterier).
- Indstillet batterispænding.
- Tilstand RECOVERY. Ekstrafunktion til genvinding af sulfurede batterier.
- Generel alarm for polvending, kortslutning, slidt eller defekt batteri.
- Tilstand SUPPLY. Tilstand SUPPLY spændingsgenerator. **Tilstand, der ikke er beskyttet mod ombytning af polaritet, kortslutning og forkert valg af spænding.**
- Opladningsfaser PULSE-TRONIC.
- Tilstand BOOST. Ekstrafunktion til lynopladning.
- Tilstand TEST.
- Test af generator og test af batteriets startevne (CCA).
- Resultat af TEST, RECOVERY og afslutning af opladning.
- Indstillingsknap:
 - PULSE-TRONIC OPLADNING (GEL, AGM, AGM +, Li, EFB og lave temperaturer ❄).
 - TEST (batteriets tilstand, batteriets startevne, køretøjsgenerator).
 - Avancerede programmer: BOOST, RECOVERY, SUPPLY.

LED-version (sd. 2)

- Indstillingsknap: Valg af ladespænding og avancerede programmer.
- Indstillet batterispænding.
- Batteriets opladningsniveau:
 - Led 25 %:** Opladning i gang.
 - Led 50 %:** Opladning i gang.
 - Led 75 %:** Opladning i gang.
 - Led 100 %:** Opladning slut.
- Avancerede programmer: **AGM** ❄, **RECOVERY, SUPPLY:**
 - **AGM** ❄
Funktion, der anvendes til at oplade

et batteri af typen "AGM" eller "WET": blybatterier, forseglede, med elektrolyt på absorberende materiale eller til at oplade et almindeligt batteri ved lave temperaturer, under 0°C ❄.

• **RECOVERY**

Ekstrafunktion til genvinding af sulfurede batterier.

• **SUPPLY**

Tilstand SUPPLY spændingsgenerator
Tilstand, der ikke er beskyttet mod ombytning af polaritet, kortslutning og forkert valg af spænding.

- Generel alarm for polvending, kortslutning, slidt eller defekt batteri.

FUNKTIONER

- PULSE-TRONIC-OPLADNING
- TEST (hvis modellen er udstyret dermed)
 - TEST AF LADETILSTAND
 - TEST AF BATTERIETS STARTEVNE (CCA)
 - TEST AF GENERATOR
- VEDLIGEHOLDELSE AF BATTERIER
 - RECOVERY
- FORSYNING
 - SUPPLY (hvis modellen er udstyret dermed)

ALARMINFO

TILSLUTNING AF LADEKABLER

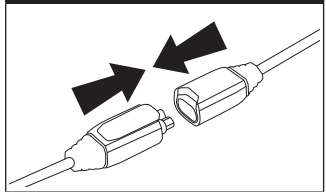

TÆNDING

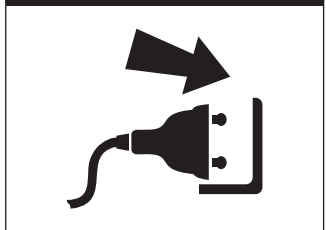

SLUKNING

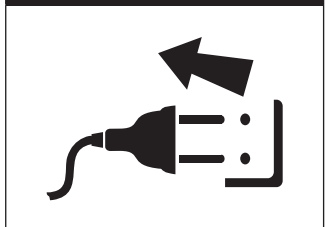

A OPLADNING/OPRETHOLDELSE

PULSE-TRONIC TECHNOLOGY



1 VALG AF SPÆNDING

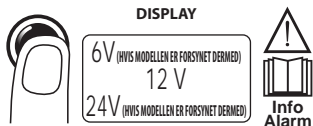

2 VALG AF PROCES Pulse-Tronic



3 EKSTRAUDSTYR: VALG AF AVANCERET MENU



Ekstraudstyr for at opnå en hurtigere opladning

4 TILSLUTNING AF TANG

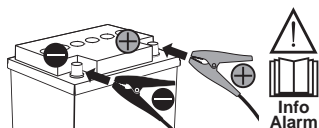

5 GRAFISK FREMSTILLING AF PULSE-TRONIC OPLADNINGSFASERNE

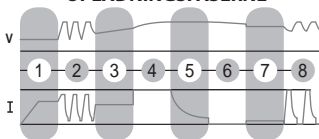

- 1 Test af batteri
- 2 Impulsgenvinding af sulferede/næsten helt afladete batterier
- 3 Kontrol af intakthed
- 4 Opladning op til 80 %
- 5 Opladning op til 100 %
- 6 Overvågning af opretholdelse af opladningsniveau
- 7 Opretholdelse af opladningsniveau (*)
- 8 Genopretning af opladningsniveau med impulser (*)

(*) Opretholdelsesfaser efter afslutning af opladning. Afbrudelsen sker efter frakobling af batteriladeren.

6 AFSLUTNING AF OPLADNING - EKSEMPEL



Afslutning af Pulse-Tronic-opladning - positivt resultat

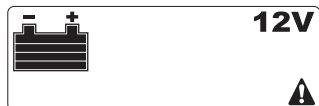

Afslutning af Pulse-Tronic-opladning - negativt resultat

B TEST

LADE TILSTAND



1 VALG AF SPÆNDING

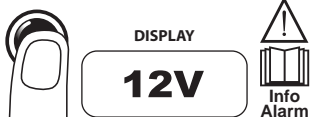

2 VALG AF TEST

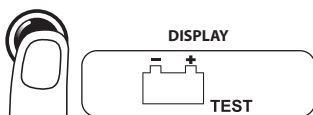

3 TILSLUTNING AF TANG

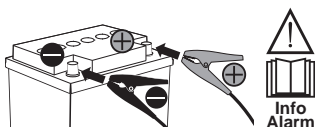

4 AFSLUTNING AF TEST - EKSEMPEL



FORKLARINGER TIL DISPLAY



helt afladet



afladet



opladet

B TEST

BATTERIETS LADEEVNE



1 VALG AF SPÆNDING



2 VALG AF TEST

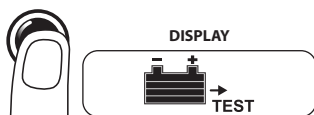

3 TILSLUTNING AF TANG

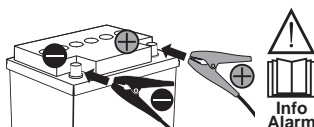

4 START AF KØRETØJ



5 AFSLUTNING AF TEST - EKSEMPEL



FORKLARINGER TIL DISPLAY



positivt



tilstrækkeligt



negativt

B TEST

GENERATOR



1 VALG AF SPÆNDING

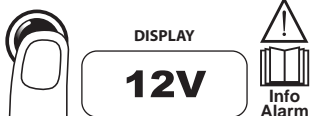

2 VALG AF TEST

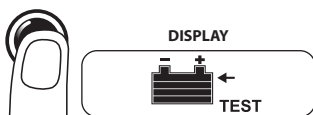

3 TILSLUTNING AF TANG

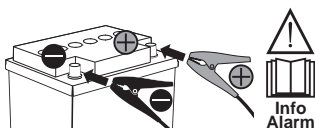

4 START AF KØRETØJ



5 AFSLUTNING AF TEST - EKSEMPEL



FORKLARINGER TIL DISPLAY



C VEDLIGEHOELSE

RECOVERY



1 VALG AF SPÆNDING



2 VALG AF AVANCERET MENU

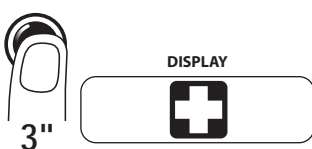

3 TILSLUTNING AF TANG

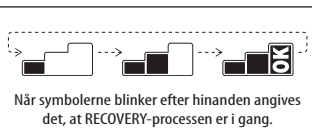
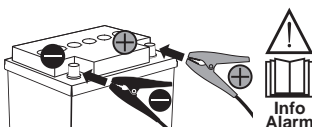

4 AFSLUTNING AF PROCES - EKSEMPEL



5 AFSLUTNING AF FUNKTION



D FORSYNING

SUPPLY

SUPPLY

SKIFT
BATTERI

1 VALG AF SPÆNDING



DISPLAY

12V



Info
Alarm

2 VALG AF AVANCERET MENU



3"

DISPLAY

SUPPLY

3 TILSLUTNING AF TANG TIL KØRETØJETS BATTERIKABLER

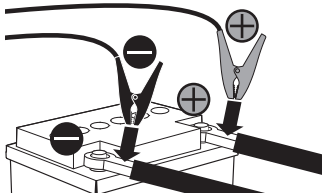

4 KØRETØJET FORSYNET MED STRØM



AFTAGNING
BATTERI



UDSKIFTNING
BATTERI

5 AFSLUTNING AF FUNKTION



3"



ALARMINFO Info
Alarm



KORTSLUTNING

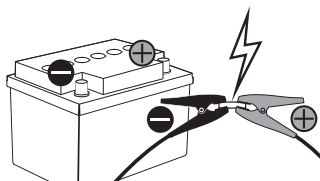

POLINVERTERING

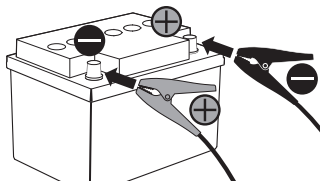

12V

12V

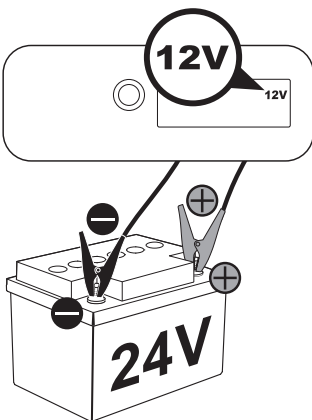

LED-version

A

OPLADNING/ OPRETHOLDELSE

PULSE-TRONIC TECHNOLOGY



1 VALG AF SPÆNDING

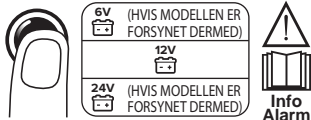

2 EKSTRAUDSTYR: VALG AF AVANCERET MENU



3 TILSLUTNING AF TANG

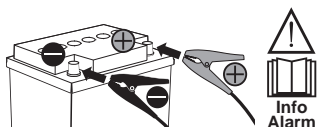

4 AFSLUTNING AF OPLADNING - EKSEMPEL



Afslutning af Pulse-Tronic-opladning - positivt resultat



Afslutning af Pulse-Tronic-opladning - negativt resultat

C

VEDLIGEHOELSELSE

RECOVERY



1 VALG AF SPÆNDING

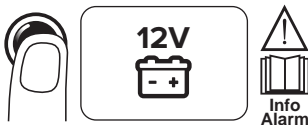

2 VALG AF AVANCERET MENU



3 TILSLUTNING AF TANG

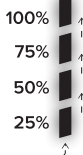
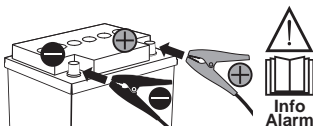

Når LED'ene blinker efter hinanden angives det, at RECOVERY-processen er i gang.

4 AFSLUTNING AF PROCES - EKSEMPEL



5 AFSLUTNING AF FUNKTION



D FORSYNING

SUPPLY

SUPPLY

SKIFT
BATTERI

1 VALG AF SPÆNDING



12V



Info
Alarm

2 VALG AF AVANCERET MENU



3"



SUPPLY

3 TILSLUTNING AF TANG TIL KØRETØJETS BATTERIKABLER

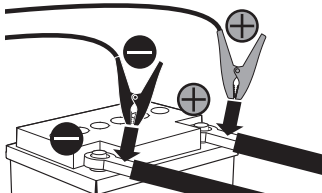

4 KØRETØJET FORSYNET MED STRØM



AFTAGNING
BATTERI



UDSKIFTNING
BATTERI

5 AFSLUTNING AF FUNKTION



3"



ALARMINFO Info
Alarm



KORTSLUTNING

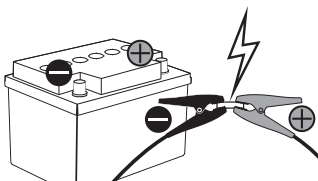

POLINVERTERING

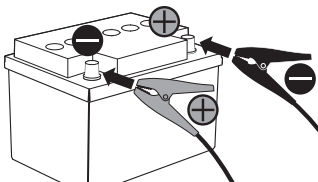

12V

12V



24V

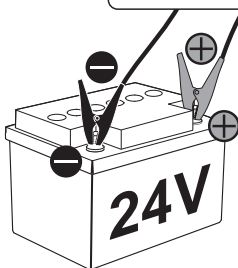

LCD versjon (side. 2)

- Batteriets ladenivå.
- Valg av batteritype:
 - **GEL:** Bly-kalsiumbatterier (PbCa) med solid elektrolytt gelatinøs type fullstendig forsegle. Vedlikeholdsfrie batterier.
 - **AGM (ABSORBENT GLASS MAT):** Blybatterier med absorbert elektrolytt i glassfiber. Fullstendig forseglede. Vedlikeholdsfrie batterier.
 - **AGM+:** de sikrer et større antall starter ved høyere strøm og større utladningsdybde enn standard AGM. Brukes i kjøretøy utstyrt med et Start-Stop-system. Liten størrelse, høyere vibrasjonsmotstand og raske ladetider.
 - **Litium (Li):** batterier med lav vekt, høy energitetthet og veldig lav selvutladning. De brukes hovedsakelig innenfor motorsport.
 - **EFB (Enhanced Flooded Battery):** flytende elektrolyttbatterier med bedre ladekapasitet og som støtter et høyere antall sykluser (starter) enn tradisjonelle batterier. Ideell for kjøretøy utstyrt med Start-Stop-system.
- Lading ved lave temperaturer (indikert også for WET-batterier).
- Innstilt batterispenning.
- RECOVERY modalitet.
Tilleggsfunksjon for å gjenopprette de sulfaterede batteriene.
- Generisk alarm for polaritetsinversjon, kortslutning, utslitt eller defekt batteri.
- SUPPLY-modus.
SUPPLY modus spenningsgenerator.
Modalitet ikke beskyttet fra polaritetombytting, kortslutning og valg av feil spenning.
- PULSE-TRONIC ladefaser.
- BOOST-modus.
Ekstrafunksjon for en hurtiglading.
- TEST-modus.
- Test av vekselstrømgenerator og batteriets oppstartkapasitet - (CCA).
- Utfall av TEST, RECOVERY og avsluttet lading.
- Innstillingsknapp:
 - PULSE-TRONIC LADING (GEL, AGM, AGM +, Li, EFB og lave temperaturer ❄).
 - TEST (batteristatus, batteriets startkapasitet, kjøretøysgenerator).
 - Avanserte programmer: BOOST, RECOVERY, SUPPLY.

LED versjon (side. 2)

- Innstillingsknapp:
Valg av ladespenning og avanserte programmer.
- Innstilt batterispenning.
- Batteriets ladenivå:
Led 25 % : lading pågår.
Led 50 % : lading pågår.
Led 75 % : lading pågår.
Led 100 % : lading slutt.
- Avanserte programmer: **AGM** ❄,
RECOVERY, SUPPLY:
 - **AGM** ❄
Nyttefunksjon for å lage batterier av "AGM" eller "WET"-type: blybatterier, forseglede, med elektrolytt på

absorberende materiale, eller, for å lade et generisk batteri ved lave temperaturer, under 0°C ❄.

• **RECOVERY**

Tilleggsfunksjon for å gjenopprette de sulfaterede batteriene.

• **SUPPLY**

SUPPLY modus spenningsgenerator

Modalitet ikke beskyttet fra polaritetombytting, kortslutning og valg av feil spenning.

- Generisk alarm for polaritetombytting, kortslutning, utslitt eller defekt batteri.

FUNKSJONER

- PULSE-TRONIC LADING
- TEST (hvor forutsett)
 - TEST LADESTATUS
 - TEST BATTERIETS OPPSTARTSKAPASITET (CCA)
 - TEST DYNAMO
- VEDLIKEHOLD AV BATTERI
 - RECOVERY
- FORSYNING
 - SUPPLY (hvor forutsett)

ALARMINFO

TILKOBLING BATTERILEDNINGER

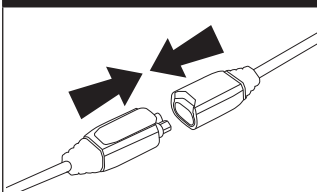

PÅSKRUING

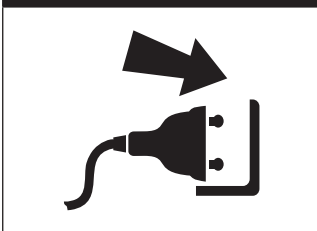

AVSKRUING

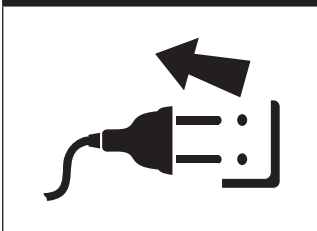

A LADING/OPPRETTTHOLDELSE

PULSE-TRONIC TEKNOLOGI



1 VELG SPENNING

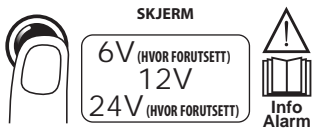

2 VELG PROSESS Pulse-Tronic



3 ALTERNATIV: VELG AVANSERT MENY



Valgfritt for raskere lading

4 KOBLE TIL KLEMMER

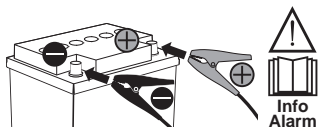

5 GRAFIKK PULSE-TRONIC LADEFASER

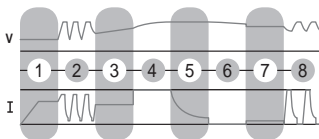

- 1 Batteritest
- 2 Impulsgjenvinning av sulfaterte/veldig utladete batterier
- 3 Kontroll av helhet
- 4 Lading opptil 80 %
- 5 Lading opptil 100 %
- 6 Ladestyringsmonitor
- 7 Opprettholdelse av lading (*)
- 8 Gjenoppretting av impulsloading (*)

(*) Vedlikeholdsfaser etter at ladingen er avsluttet.

Avbruddet oppstår etter at du har koblet fra laderen.

6 LADESLUTT - EKSEMPEL



Ladeslutt PULSE - TRONIC - Positivt resultat

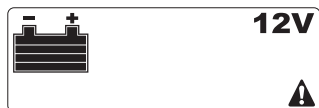

Ladeslutt PULSE - TRONIC - Negativt resultat

B TEST

LADESTATUS



1 VELG SPENNING



SKJERM

12V



2 VELG TEST



SKJERM



TEST

3 KOBLE TIL KLEMMER

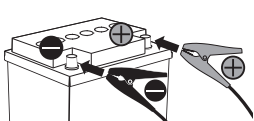

4 TESTSLUTT - EKSEMPEL



TEST

12V

FORKLARING SKJERM



veldig utladet



utladet



ladet

B TEST

BATTERIETS STARTKAPASITET



1 VELG SPENNING



SKJERM

12V



2 VELG TEST



SKJERM



TEST

3 KOBLE TIL KLEMMER

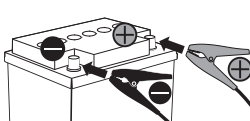

4 START AV KJØRETØY



5 TESTSLUTT - EKSEMPEL



TEST

FORKLARING SKJERM



positiv



tilstrekkelig



negativ

B TEST

VEKSELSTRØMGENERATOR  ←

1 VELG SPENNING



2 VELG TEST

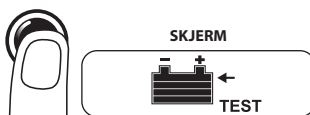

3 KOBLE TIL KLEMMER

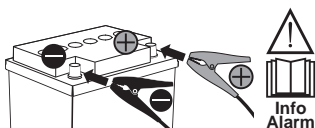

4 START AV KJØRETØY



5 TESTSLUTT - EKSEMPEL



FORKLARING SKJERM



C VEDLIKEHOLD

RECOVERY 

1 VELG SPENNING



2 VELG AVANSERT MENY



3 KOBLE TIL KLEMMER

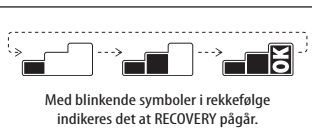
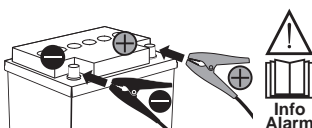

4 PROSESSLUTT - EKSEMPEL



5 GÅ UT FRA FUNKSJON



D FORSYNING

SUPPLY

SUPPLY

BYTTE
BATTERI

1 VELG SPENNING



SKJERM

12V



Info
Alarm

2 VELG AVANSERT MENY



3"

SKJERM

SUPPLY

3 KOBLE TIL KLEMMER BATTERI KJØRETØY

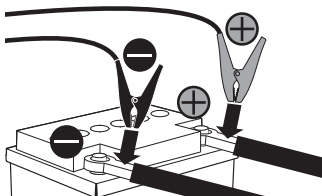

4 KJØRETØY STRØMSATT



FJERNING
BATTERI



UTSKIFTNING
BATTERI

5 GÅ UT FRA FUNKSJON



3"



ALARMINFO Info
Alarm



KORTSLUTNING

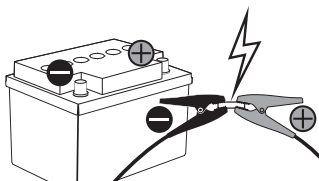

OMSTILLING POLER

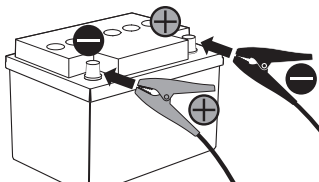

12V

12V

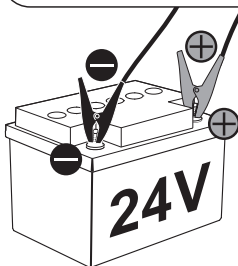

LED-versjon

A LADNING/ VEDLIKEHOLD

PULSE-TRONIC TEKNOLOGI



1 VELG SPENNING

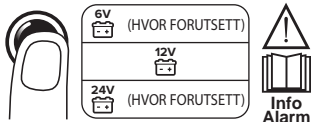

2 ALTERNATIV: VELG AVANSERT MENY



3 KOBLE TIL KLEMMER

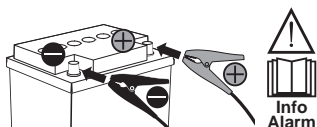

4 LADESLUTT - EKSEMPEL

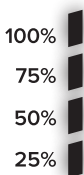

Ladeslutt PULSE - TRONIC - Positivt resultat



Ladeslutt PULSE - TRONIC - Negativt resultat

C VEDLIKEHOLD

RECOVERY

1 VELG SPENNING

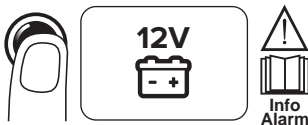

2 VELG AVANSERT MENY



3 KOBLE TIL KLEMMER

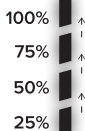
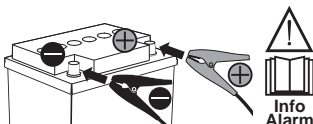

Med blinkende LED i rekkefølge indikeres det at RECOVERY pågår.

4 PROSESSLUTT - EKSEMPEL



5 GÅ UT FRA FUNKSJON



D FORSYNING

SUPPLY

SUPPLY

BYTTE
BATTERI

1 VELG SPENNING



12V



Info
Alarm

2 VELG AVANSERT MENY



3"



SUPPLY

3 KOBLE TIL KLEMMER BATTERI KJØRETØY

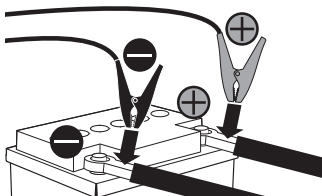

4 KJØRETØY STRØMSATT



FJERNING
BATTERI

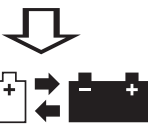

UTSKIFTNING
BATTERI

5 GÅ UT FRA FUNKSJON



3"



ALARMINFO Info
Alarm



KORTSLUTNING

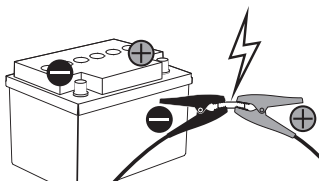

OMSTILLING POLER

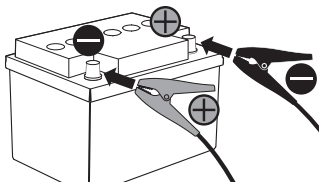

12V

12V



24V

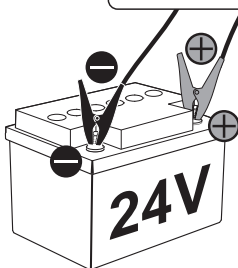

Različica LCD (stran 2)

1. Stopnja napoljenosti akumulatorja.
2. Izbira tipa akumulatorja:
 - **GEL:** akumulatorji na svinec-kalcij (PbCa) s trdnim želatinastim elektrolitom, ki so popolnoma zatesnjeni. To so akumulatorji, ki ne potrebujejo vzdrževanja.
 - **AGM (ABSORBENT GLASS MAT):** akumulatorji na svinec z elektrolitom v steklenih vlaknih. Popolnoma zatesnjeni. To so akumulatorji, ki ne potrebujejo vzdrževanja.
 - **AGM+:** zagotavljajo večje število zagonov pri večjem toku in večjo izpraznjenost kot standardni akumulatorji AGM. Uporabljajo se v vozilih, opremljenih s sistemom Start-Stop. Manjši, bolj odporni na vibracije, hitro se polnijo.
 - **Litij (Li):** lažji akumulatorji, velika energijska gostota in zelo zelo nizko samodejno praznjenje. Uporabljajo se večinoma v svetu športnega motorizma.
 - **EFB (Enhanced Flooded Battery):** akumulatorji s tekočim elektrolitom z boljšo zmogljivostjo polnjenja, ki podpirajo večjo količino ciklov (zagonov) glede na tradicionalne akumulatorje. Idealni za vozila, opremljena s sistemom Start-Stop.
3. Polnjenje pri nizkih temperaturah (tudi za akumulatorje WET).
4. Nastavljena napetost akumulatorja.
5. Način RECOVERY.
Dodatna funkcija za obnavljanje sulfatiranih akumulatorjev.
6. Splošni alarm zaradi inverzne polaritete, kratek stik, iztrošen ali pokvarjen akumulator.
7. Način SUPPLY.
Način SUPPLY generator napetosti.
Način ni zaščiten pred inverzno polariteto, kratkim stikom in napačno izbiro napetosti.
8. Faze polnjenja PULSE-TRONIC.
9. Način BOOST.
Dodatna funkcija za hitro polnjenje.
10. Način TEST.
11. Preizkus alternatorja in preizkus zmogljivosti zagona akumulatorja (CCA).
12. Izid preizkusa, recovery in konec polnjenja.
13. Gumb za nastavitve:
 - POLNENJE PULSE-TRONIC (GEL, AGM, AGM +, Li, EFB in nizke temperature ❄).
 - TEST (stanje akumulatorja, zmogljivost zagona akumulatorja, alternator vozila).
 - Napredni programi: BOOST, RECOVERY, SUPPLY.

Različica s svetlečimi diodami LED (stran 2)

1. Gumb za nastavitve:
Izbira napetosti za polnjenje in napredni programi.
2. Nastavljena napetost akumulatorja.
3. Stopnja napoljenosti akumulatorja:
Svetleča dioda 25% : polnjenje poteka.
Svetleča dioda 50% : polnjenje poteka.
Svetleča dioda 75% : polnjenje poteka.
Svetleča dioda 100% : konec polnjenja.
4. Napredni programi: **AGM** ❄, **RECOVERY**, **SUPPLY**:
 - **AGM** ❄
Funkcija za polnjenje akumulatorja tipa

"AGM" ali "WET": zapečateni svinčevi akumulatorji z elektrolitom na vpojnem materialu, ali za polnjenje generičnih akumulatorjev pri nizkih temperaturah pod 0° C ❄.

• RECOVERY

Dodatna funkcija za obnavljanje sulfatiranih akumulatorjev.

• SUPPLY

Način SUPPLY generator napetosti

Način ni zaščiten pred inverzno polariteto, kratkim stikom in napačno izbiro napetosti.

5. Splošni alarm zaradi inverzne polaritete, kratek stik, iztrošen ali pokvarjen akumulator.

FUNKCIJE

- A. POLNENJE PULSE TRONIC
- B. TEST (kjer je predvideno)
 - PRESKUS STOPNJE NAPOLNJENOSTI
 - PRESKUS ZMOGLJIVOSTI ZAGONA AKUMULATORJA (CCA)
 - PRESKUS ALTERNATORJA
- C. VZDRŽEVANJE AKUMULATORJEV
 - RECOVERY
- D. NAPAČANJE
 - SUPPLY (kjer je predvideno)

INFORMACIJE O ALARMIH

PRIKLUČITEV KABLOV ZA POLNLENJE

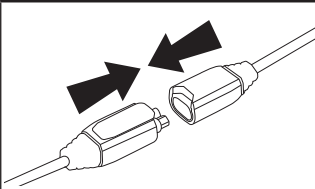

VŽIG



UGAŠANJE

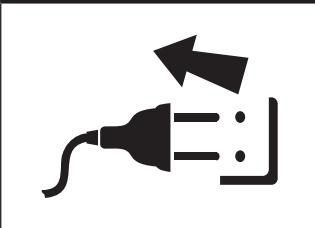

A POLNJENJE/VZDRŽEVANJE

TEHNOLOGIJA PULSE-TRONIC



1 IZBIRA NAPETOSTI

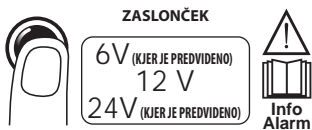

2 IZBIRA POSTOPKA Pulse-tronic



3 OPCIJSKO: IZBIRA NAPREDNEGA MENUJA



Opcijsko za hitrejše polnjenje

4 PRIKLJUČEVANJE KLEŠČ

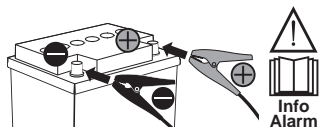

5 FAZE POLNJENJA PULSE-TRONIC

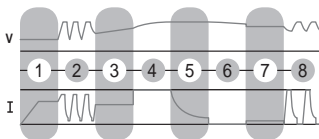

- 1 Preizkus akumulatorja
- 2 Obnovitev sulfatiranih/zelo praznih akumulatorjev z impulzi
- 3 Preverjanje celovitosti
- 4 Polnjenje do 80 %
- 5 Polnjenje do 100 %
- 6 Monitor vzdrževanja napolnjenosti
- 7 Vzdrževanje napolnjenosti (*)
- 8 Povrnitev impulznega polnjenja v prvotno stanje (*)

(*) Vzdrževalne faze po koncu polnjenja. Do prekinitve pride, ko odklopite polnilnik akumulatorjev.

6 KONEC POLNJENJA - ZGLED



Konec polnjenja Pulse-Tronic - pozitiven izid



Konec polnjenja Pulse-Tronic - negativen izid

B TEST - PRESKUS

STANJE
NAPOLNJENOSTI



1 IZBIRA NAPETOSTI



ZASLONČEK

12V



Info
Alarm

2 IZBIRA PRESKUSA



ZASLONČEK



TEST

3 PRIKLJUČEVANJE KLEŠČ

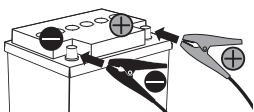

Info
Alarm

4 KONEC PRESKUSA - ZGLED



TEST

12V

LEGENDA ZASLONČKA



zelo prazen



izpust



funkcija

B TEST - PRESKUS

ZMOGLJIVOST ZAGONA
AKUMULATORJA



1 IZBIRA NAPETOSTI



ZASLONČEK

12V



Info
Alarm

2 IZBIRA PRESKUSA



ZASLONČEK



TEST

3 PRIKLJUČEVANJE KLEŠČ

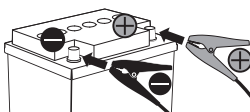

Info
Alarm

4 ZAGON VOZILA



5 KONEC PRESKUSA - ZGLED



TEST

LEGENDA ZASLONČKA



pozitiven



zadosten



negativen

B TEST - PRESKUS

ALTERNATOR



1 IZBIRA NAPETOSTI



ZASLONČEK

12V



2 IZBIRA PRESKUSA



ZASLONČEK



TEST

3 PRIKLJUČEVANJE KLEŠČ

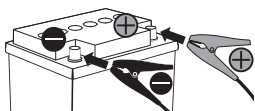

4 ZAGON VOZILA



5 KONEC PRESKUSA - ZGLED

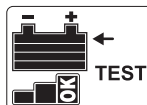

LEGENDA ZASLONČKA



pozitiven



zadosten



negativen

C VZDRŽEVANJE

RECOVERY



1 IZBIRA NAPETOSTI



ZASLONČEK

12V



2 IZBIRA NAPREDNEGA MENUJA



ZASLONČEK



3"

3 PRIKLJUČEVANJE KLEŠČ

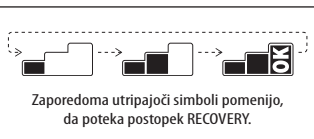
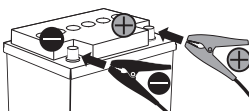

Zaporedoma utripajoči simboli pomenijo, da poteka postopek RECOVERY.

4 KONEC POSTOPKA - ZGLED



5 IZHOD IZ FUNKCIJE



3"

D NAPAJANJE

SUPPLY

SUPPLY

MENJAVA
AKUMULATOR

1 IZBIRA NAPETOSTI



ZASLONČEK

12V



Info
Alarm

2 IZBIRA NAPREDNEGA MENUJA



ZASLONČEK

SUPPLY

3"

3 PRIKLJUČEVANJE KLEŠČ NA KABLIH NA AKUMULATOR VOZILA

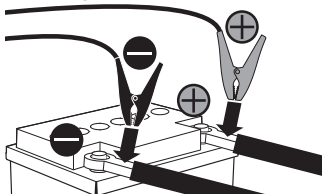

4 NAPAJANO VOZILO

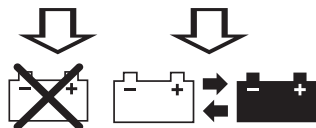

ODSTRANJEVANJE ZAMENJAVA
AKUMULATORJA
AKUMULATORJA

5 IZHOD IZ FUNKCIJE



3"



INFORMACIJE
O ALARMIH



Info
Alarm



KRATEK STIK

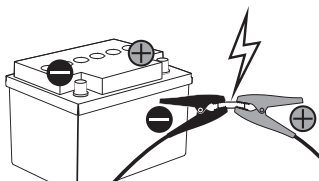

INVERZIJA POLARITETE

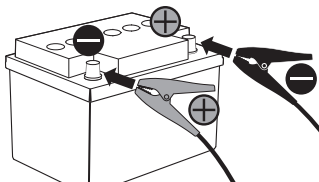

12V

12V

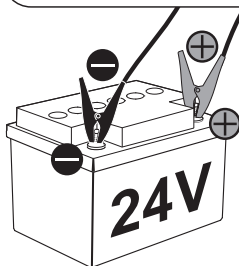

Različica s svetlečimi diodami LED

A POLNITEV/ VZDRŽEVANJE

TEHNOLOGIJA PULSE-TRONIC



1 IZBIRA NAPETOSTI

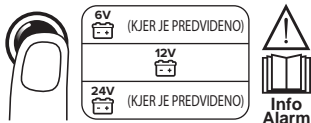

2 OPCISKO: IZBIRA NAPREDNEGA MENUJA



3 PRIKLJUČEVANJE KLEŠČ

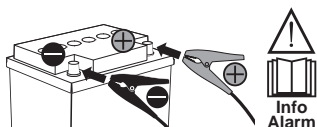

4 KONEC POLNJENJA - ZGLED

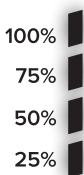

Konec polnjenja Pulse-Tronic - pozitiven izid



Konec polnjenja Pulse-Tronic - negativen izid

C VZDRŽEVANJE

RECOVERY



1 IZBIRA NAPETOSTI

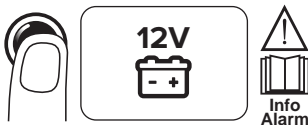

2 IZBIRA NAPREDNEGA MENUJA



3 PRIKLJUČEVANJE KLEŠČ

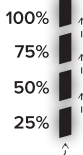
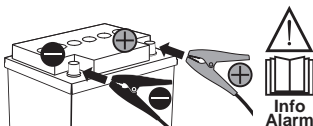

Ko svetleče diode utripajo zaporedoma, to pomeni da poteka postopek RECOVERY.

4 KONEC POSTOPKA - ZGLED



5 IZHOD IZ FUNKCIJE



D NAPAJANJE

SUPPLY

SUPPLY

MENJAVA
AKUMULATOR

1 IZBIRA NAPETOSTI



12V



Info
Alarm

2 IZBIRA NAPREDNEGA MENUJA



3"

SUPPLY

3 PRIKLJUČEVANJE KLEŠČ NA KABLIH NA AKUMULATOR VOZILA

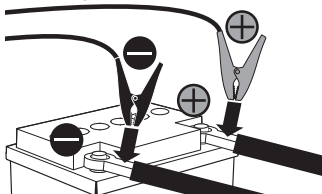

4 NAPAJANO VOZILO



ODSTRANJEVANJE ZAMENJAVA
AKUMULATORJA
AKUMULATORJA

5 IZHOD IZ FUNKCIJE



3"



INFORMACIJE
O ALARMIH



Info
Alarm



KRATEK STIK

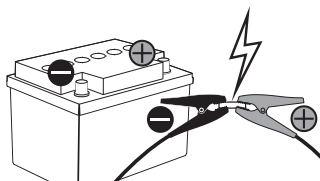

INVERZIJA POLARITETE

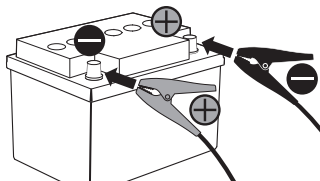

12V

12V



24V

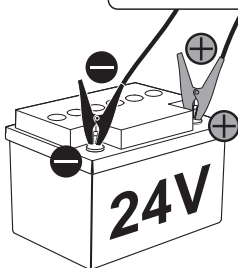

Verzia LCD (str. 2)

- Úroveň nabitia akumulátora.
- Voľba typu akumulátora:
 - GEL:** olovené-vápenaté (PbCa) akumulátory s pevným želatinovým elektrolytom, úplne hermeticky uzatvorené. Jedná sa o bezúdržbové akumulátory.
 - AGM (ABSORBENT GLASS MAT):** olovené akumulátory s elektrolytom absorbovaným v sklenených vláknach. Úplne hermeticky uzatvorené. Jedná sa o bezúdržbové akumulátory.
 - AGM+:** zaisťujú vyšší počet štartovacích cyklov pri vyššom prúde a väčšiu hĺbku vybitia ako štandardné AGM. Používajú sa vo vozidlách, vybavených systémom Start-Stop. Vyznačujú sa obmedzenými rozmermi, väčšou odolnosťou voči vibráciám a rýchlym dobitím.
 - Lítium (Li):** akumulátory s obmedzenou hmotnosťou, vysokou energetickou hustotou a veľmi nízkym samovybíjaním. Používajú sa predovšetkým vo svete motoristického športu.
 - EFB (Enhanced Flooded Battery):** akumulátory s tekutým elektrolytom a s lepšou kapacitou nabíjania, ktoré znášajú vyšší počet cyklov (štartovanie) ako klasické akumulátory. Sú ideálne pre vozidlá vybavené systémom Start-Stop.
- Nabíjanie pri nízkych teplotách (vhodné aj pre akumulátory WET).
- Nastavené napätie akumulátora.
 - Režim RECOVERY. Prídavná funkcia ktorá slúži na obnovenie akumulátorov, v ktorých sa vytvoril síran.
- Všeobecný alarm, upozorňujúci na zmenu polaritu, skrat, opotrebovaný alebo chybný akumulátor.
- Režim SUPPLY.
 - Režim SUPPLY napätového generátora.
 - Režim nechránený pred zámennou polaritou, skratom a chybnou voľbou napätia.**
- Fázy nabíjania PULSE-TRONIC.
- Režim BOOST.
 - Prídavná funkcia pre rýchle nabíjanie.
- Režim TEST.
 - Test alternátora a test štartovacej kapacity akumulátora (CCA).
- Výsledok TESTU, RECOVERY a ukončenie nabíjania.
- Tlačidlo nastavenia:
 - NABÍJANIE PULSE-TRONIC (GEL, AGM, AGM +, Li, EFB a nízke teploty ❄️).
 - TEST (stav akumulátora, štartovacia kapacita akumulátora, alternátor vozidla).
 - Pokročilé programy: BOOST, RECOVERY, SUPPLY.

Verzia LED (str. 2)

- Tlačidlo nastavenia:
 - Voľba nabíjacieho napätia a pokročilé programy.
- Nastavené napätie akumulátora.
- Úroveň nabitia akumulátora:
 - LED 25 %:** prebiehajúce nabíjanie.
 - LED 50 %:** prebiehajúce nabíjanie.
 - LED 75 %:** prebiehajúce nabíjanie.
 - LED 100 %:** ukončenie nabíjania.
- Pokročilé programy: **AGM** ❄️, **RECOVERY**, **SUPPLY**:

- AGM** ❄️
Funkcia užitočná pre nabíjanie akumulátora typu „AGM“ alebo „WET“: olovené, hermeticky uzavreté akumulátory, s elektrolytom na absorpčnom materiáli, alebo pre nabíjanie štandardného akumulátora pri základných teplotných podmienkach, pod 0 °C - ❄️.
 - RECOVERY**
Prídavná funkcia ktorá slúži na obnovenie akumulátorov, v ktorých sa vytvoril síran.
 - SUPPLY**
Režim SUPPLY napätového generátora
Režim nechránený pred zámennou polaritou, skratom a chybnou voľbou napätia.
- Všeobecný alarm, upozorňujúci na zmenu polaritu, skrat, opotrebovaný alebo chybný akumulátor.

FUNKCIE

- NABÍJANIE PULSE-TRONIC
- TEST (ak je súčasťou)
 - TEST STAVU NABITIA
 - TEST ŠTARTOVEJ KAPACITY AKUMULÁTORA (CCA)
 - TEST ALTERNÁTORA
- ÚDRŽBA AKUMULÁTOROV
 - RECOVERY
- NAPÁJANIE
 - SUPPLY (ak je súčasťou)

INFORMÁCIE O ALARMOCH

PRIPOJENIE NABÍJACÍCH KÁBLOV

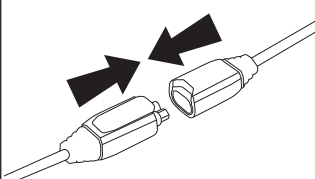

ZAPNUTIE

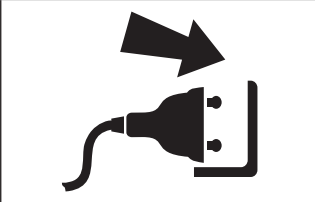

VYPNUTIE

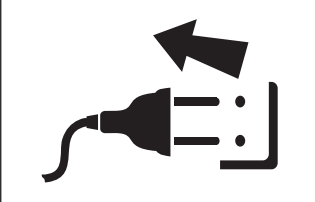

A NABÍJANIE/UDRŽIAVANIE

PULSE-TRONIC TECHNOLOGY



1 VOĽBA NAPÄTIA

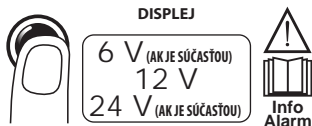

2 VOĽBA PROCESU Pulse-Tronic



3 VOLITEĽNÁ FUNKCIA: VOĽBA POKROČILEJ PONUKY



Voliteľná funkcia pre rýchlejšie nabíjanie

4 PRIPOJENIE KLIESTÍ

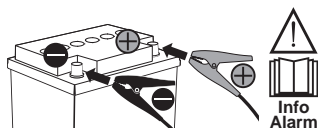

5 GRAF FÁZ NABÍJANIA PULSE-TRONIC

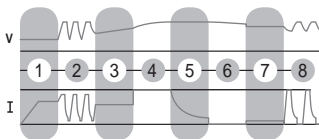

- 1 Test akumulátora
- 2 Obnovenie akumulátorov, v ktorých došlo k impulzov vytvoreniu síranu / veľmi vybitých akumulátorov
- 3 Kontrola neporušenosti
- 4 Nabitie až na 80 %
- 5 Nabitie až na 100 %
- 6 Monitorovanie udržiavania nabitia
- 7 Udržiavanie nabitia (*)
- 8 Impulzné obnovenie nabitia (*)

(*) Fáza udržiavania po ukončení nabíjania. Ich prerušenie prebehne po odpojení nabíjačky akumulátorov.

6 UKONČENIE NABÍJANIA - PRÍKLAD



Ukončenie nabíjania Pulse-Tronic - kladný výsledok



Ukončenie nabíjania Pulse-Tronic - záporný výsledok

B TEST

STAV NABITIA



1 VOĽBA NAPÄTIA



DISPLEJ

12V



2 VOĽBA SKÜŠKY



DISPLEJ

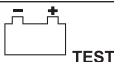

3 PRIPOJENIE KLIESTÍ

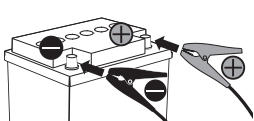

4 UKONČENIE SKÜŠKY - PRÍKLAD



12V

TEST

VYSVETLIVKY K DISPLEJU



velmi vybitý



vybitý



nabý

B TEST

ŠTARTOVACIA KAPACITA
AKUMULÁTORA



1 VOĽBA NAPÄTIA



DISPLEJ

12V



2 VOĽBA SKÜŠKY



DISPLEJ



3 PRIPOJENIE KLIESTÍ

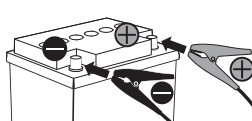

4 ŠTARTOVANIE VOZIDLA



5 UKONČENIE SKÜŠKY - PRÍKLAD



TEST

VYSVETLIVKY K DISPLEJU



kladný



dostatočný



záporný

B TEST

ALTERNÁTOR



1 VOĽBA NAPÄTIA



DISPLEJ

12V



2 VOĽBA SKÚŠKY



DISPLEJ



TEST

3 PRIPOJENIE KLIESTÍ

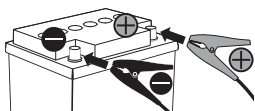

4 ŠARTOVANIE VOZIDLA



5 UKONČENIE SKÚŠKY - PRÍKLAD

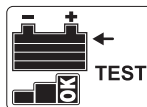

VYSVETLIVKY K DISPLEJU



kladný



dostatočný



záporný

C ÚDRŽBA

RECOVERY



1 VOĽBA NAPÄTIA



DISPLEJ

12V



2 VOĽBA POKROČILEJ PONUKY



DISPLEJ

3"



3 PRIPOJENIE KLIESTÍ

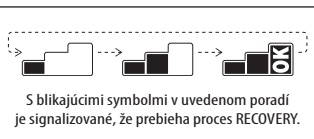
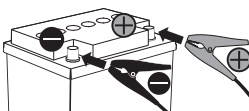

S blikajúcimi symbolmi v uvedenom poradí je signalizované, že prebieha proces RECOVERY.

4 UKONČENIE PROCESU - PRÍKLAD



5 UKONČENIE ZOBRAZOVANIA FUNKCIE



3"

D NAPÁJANIE

SUPPLY

SUPPLY

VÝMENA
AKUMULÁTORA

1 VOĽBA NAPÄTIA



DISPLEJ

12V



Info
Alarm

2 VOĽBA POKROČILEJ PONUKY



DISPLEJ

SUPPLY

3"

3 PRIPOJENIE KLIESTÍ KU KÁBLOM AKUMULÁTORA VOZIDLA

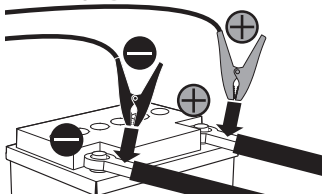

4 NAPÁJANÉ VOZIDLO

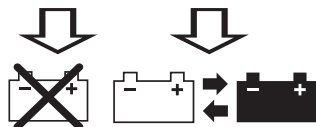

ODSTRÁNENIE
AKUMULÁTORA

VÝMENA
AKUMULÁTORA

5 UKONČENIE ZOBRAZOVANIA FUNKCIE



3"



INFORMÁCIE
O ALARMOCH



Info
Alarm



SKRAT

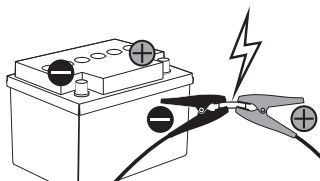

ZÁMENA POLARITY

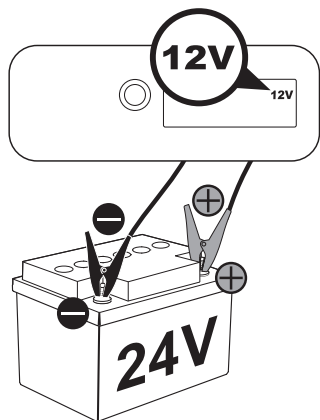
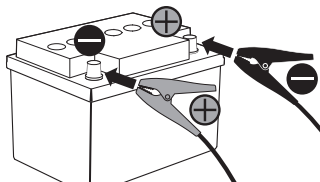

Verzia LED

A NABÍJANIE/ UDRŽIAVANIE

PULSE-TRONIC TECHNOLOGY



1 VOĽBA NAPÄTIA

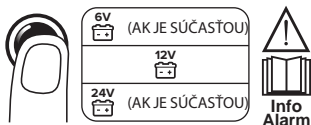

2 VOLITEĽNÁ FUNKCIA: VOĽBA POKROČILEJ PONUKY



3 PRIPOJENIE KLIESTÍ

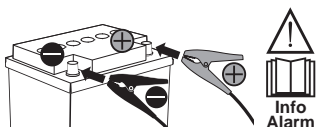

4 UKONČENIE NABÍJANIA - PRÍKLAD



Ukončenie nabíjania Pulse-Tronic - kladný
výsledok



Ukončenie nabíjania Pulse-Tronic - záporný
výsledok

C ÚDRŽBA

RECOVERY



1 VOĽBA NAPÄTIA

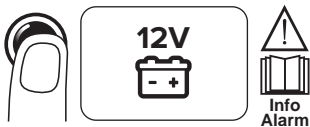

2 VOĽBA POKROČILEJ PONUKY



3 PRIPOJENIE KLIESTÍ

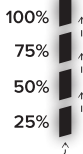
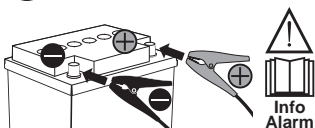

Postupne
blikajúcimi LED
je signalizované,
že prebieha
proces RECOVERY.

4 UKONČENIE PROCESU - PRÍKLAD



5 UKONČENIE ZOBRAZOVANIA FUNKCIE



D NAPÁJANIE

SUPPLY

SUPPLY

VÝMENA
AKUMULÁTORA

1 VOĽBA NAPÄTIA



12V



Info
Alarm

2 VOĽBA POKROČILEJ PONUKY



3"



SUPPLY

3 PRIPOJENIE KLIESTÍ KU KÁBLOM AKUMULÁTORA VOZIDLA

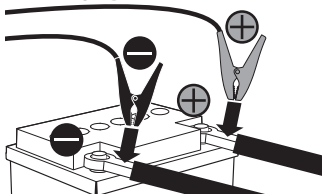

4 NAPÁJANÉ VOZIDLO



ODSTRÁNENIE
AKUMULÁTORA



VÝMENA
AKUMULÁTORA

5 UKONČENIE ZOBRAZOVANIA FUNKCIE



3"



INFORMÁCIE
O ALARMOCH



Info
Alarm



SKRAT

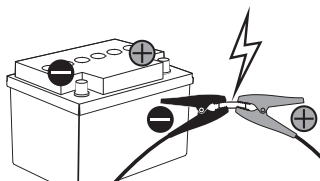

ZÁMENA POLARITY

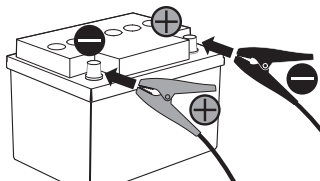

12V

12V



24V

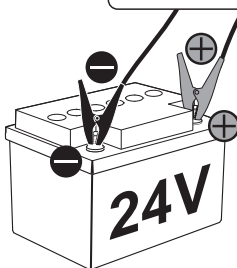

LCD verzió (2. old.)

- Az akkumulátor töltöttségi szintje.
- Akkumulátor típus választéka:
 - **ZSELÉS:** elzselésített típusú, szilárd elektrolitos, teljesen zárt, Ólom-Kálcium (PbCa) ötvözetű akkumulátorok. Ezek karbantartás nélküli akkumulátorok.
 - **AGM (ABSORBENT GLASS MAT):** üvegszállal felszívott elektrolitos Ólomakkumulátorok. Teljesen zártak. Ezek karbantartás nélküli akkumulátorok.
 - **AGM+:** az indítások magasabb számát nagyobb áramon és nagyobb kisütési mélységet biztosítanak a hagyományos AGM-ekhez képest. Start-Stop rendszerrel felszerelt járműveknél használatosak. Kisebb méretek, a rezgéseknek való nagyobb ellenállás és gyors töltési idők.
 - **Lítimos (Li):** kis súlyú, magas energiasűrűségű és nagyon alacsony önkisülésű akkumulátorok. Alapvetően a motorsport világában alkalmazzák.
 - **EFB (Enhanced Flooded Battery):** folyékony elektrolitos, jobb töltőképességű akkumulátorok, amelyek nagyobb mennyiségű ciklust (indítást) elbírnak a hagyományosokhoz képest. Start-Stop rendszerrel felszerelt járműveknél ideálisak.
- Töltés alacsony hőmérsékleteken (WET akkumulátorokhoz is javasolt).
- Beállított akkumulátor-feszültség.
- RECOVERY üzemmód.
Kiegészítő funkció, az elszulfátosodott akkumulátorok feljavításához.
- Polaritás felcserélés, rövidzárlat, elhasználódott vagy meghibásodott akkumulátor miatti, általános riasztás.
- SUPPLY üzemmód.
Feszültséggenerátor SUPPLY üzemmód.
Polaritás cserétől, rövidzárlattól és a feszültség téves megválasztásától nem védett üzemmód.
- PULSE-TRONIC töltési fázisok.
- BOOST üzemmód.
Hozzáadott funkció egy gyors töltéshez.
- TESZT üzemmód.
- Generátor teszt és Akkumulátor indítóképességi teszt (CCA).
- TESZT kimenetele, RECOVERY és töltés vége.
- Beállítás gomb:
 - PULSE-TRONIC TÖLTÉS (ZSELÉS, AGM, AGM +, Li, EFB és alacsony hőmérsékletek ❄).
 - TESZT (akkumulátor állapot, akkumulátor indítóképesség, jármű generátor).
 - Haladó Programok: BOOST, RECOVERY, SUPPLY.

LED verzió (2. old.)

- Beállítás gomb:
A töltőfeszültség és a haladó programok kiválasztása.
- Beállított akkumulátor-feszültség.
- Az akkumulátor töltöttségi szintje:
Led 25% : töltés folyamatban.
Led 50% : töltés folyamatban.
Led 75% : töltés folyamatban.
Led 100% : töltés vége.
- Haladó Programok: **AGM ❄, RECOVERY, SUPPLY:**

- **AGM ❄**
Egy "AGM" vagy "WET" típusú akkumulátor töltéséhez hasznos funkció: nedvszívó anyaggal felitatott elektrolitú, zárt ólomakkumulátorok, vagy egy általános akkumulátor töltéséhez alacsony hőmérsékleti, 0°C alatti feltételek mellett ❄.
 - **RECOVERY**
Kiegészítő funkció, az elszulfátosodott akkumulátorok feljavításához.
 - **SUPPLY**
Feszültséggenerátor SUPPLY üzemmód
Polaritás cserétől, rövidzárlattól és a feszültség téves megválasztásától nem védett üzemmód.
- Polaritás felcserélés, rövidzárlat, elhasználódott vagy meghibásodott akkumulátor miatti, általános riasztás.

FUNKCIÓK

- PULSE-TRONIC TÖLTÉS
- TESZT (ahol előírt)
 - TÖLTÉSI ÁLLAPOT TESZT
 - AKKUMULÁTOR INDÍTÓKÉPESSÉGI TESZT (CCA)
 - GENERÁTOR TESZT
- AKKUMULÁTOROK KARBANTARTÁSA
 - RECOVERY
- TÁPELLÁTÁS
 - SUPPLY (ahol előírt)

RIASZTÁS INFÓ

TÖLTŐKÁBELEK CSATLAKOZTATÁSA

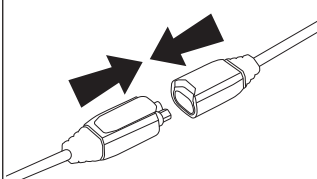

BEKAPCSOLÁS

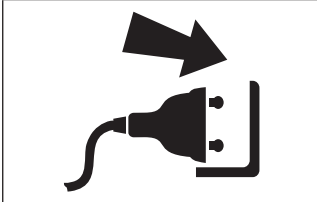

KIKAPCSOLÁS

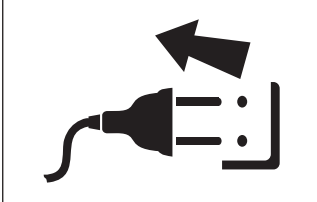

A TÖLTÉS/MEGTARTÁS

**PULSE-TRONIC
TECHNOLÓGIA**

- + - + - + - + - + - +
GEL AGM AGM+ Li EFB WET

1 FESZÜLTÉG KIVÁLASZTÁSA



2 FOLYAMAT KIVÁLASZTÁSA Pulse-Tronic



3 OPCIONÁLIS: HALADÓ MENÜ KIVÁLASZTÁSA



Opcionális egy gyorsabb töltéshez

4 CSIPESZEK CSATLAKOZTATÁSA

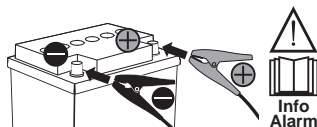

5 PULSE-TRONIC TÖLTÉSI FÁZIS GRAFIKON

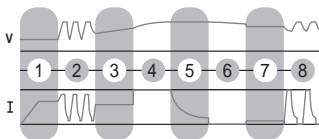

- 1 Akkumulátor teszt
- 2 Elszulfátosodott/nagyon lemerült
akkumulátorok impulzusos feljavítása
- 3 Épség ellenőrzése
- 4 Feltöltés 80%-ig
- 5 Feltöltés 100%-ig
- 6 Töltés megtartás monitor
- 7 Töltöttség megtartása (*)
- 8 Impulzustöltés visszaállítása (*)

(*) Megtartási fázis a töltés vége után.
A megszakításuk az akkumulátortöltő kicsatlakoztatása után történik meg.

6 TÖLTÉS VÉGE - PÉLDA



Pulse-Tronic töltés vége - Eredmény pozitív

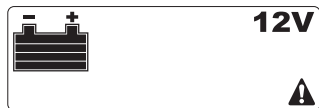

Pulse-Tronic töltés vége - Eredmény negatív

B TESZT

TÖLTÖTTSEGI ÁLLAPOT 

1 FESZÜLTÉG KIVÁLASZTÁSA



2 TESZT KIVÁLASZTÁSA

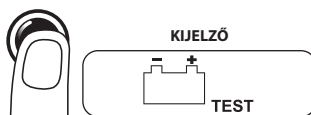

3 CSIPESZEK CSATLAKOZTATÁSA

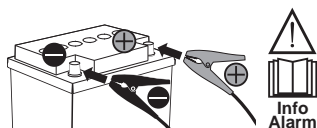

4 TESZT VÉGE - PÉLDA



KIJELZŐ JELMAGYARÁZAT

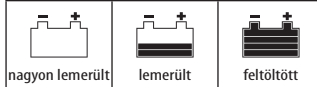

B TESZT

AKKUMULÁTOR INDÍTÓKÉPESSÉG 

1 FESZÜLTÉG KIVÁLASZTÁSA



2 TESZT KIVÁLASZTÁSA

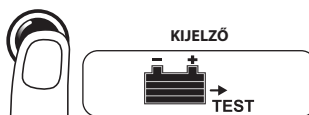

3 CSIPESZEK CSATLAKOZTATÁSA

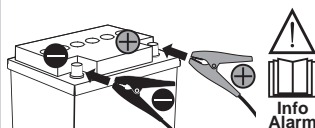

4 JÁRMŰ BEINDÍTÁSA



5 TESZT VÉGE - PÉLDA



KIJELZŐ JELMAGYARÁZAT



B TESZT

GENERÁTOR



1 FESZÜLTÉG KIVÁLASZTÁSA



2 TESZT KIVÁLASZTÁSA

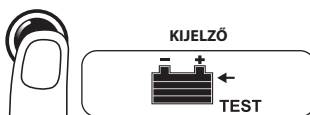

3 CSIPESZEK CSATLAKOZTATÁSA

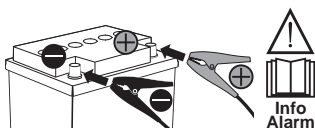

4 JÁRMŰ BEINDÍTÁSA



5 TESZT VÉGE - PÉLDA



KIJELZŐ JELMAGYARÁZAT



C KARBANTARTÁS

RECOVERY



1 FESZÜLTÉG KIVÁLASZTÁSA



2 HALADÓ MENÜ KIVÁLASZTÁSA



3 CSIPESZEK CSATLAKOZTATÁSA

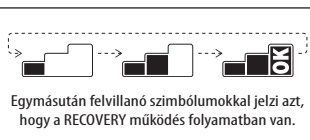
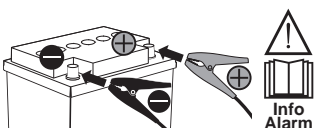

4 FOLYAMAT VÉGE - PÉLDA



5 KILÉPÉS A FUNKCIÓBÓL



D TÁPELLÁTÁS

SUPPLY SUPPLY

AKKUMULÁTOR
CSERE

1 FESZÜLTÉG KIVÁLASZTÁSA



KIJELZŐ

12V



KIJELZŐ

SUPPLY

3 CSIPESZEK CSATLAKOZTATÁSA A JÁRMŰ AKKUMULÁTORÁNAK KÁBELEIHEZ

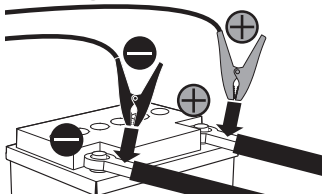

4 TÁPELLÁTOTT JÁRMŰ

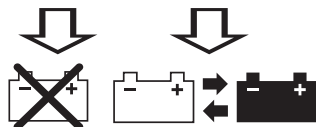

AKKUMULÁTOR
ELTÁVOLÍTÁSA

AKKUMULÁTOR
CSERE

5 KILÉPÉS A FUNKCIÓBÓL



3"



RIASZTÁS
INFO



RÖVIDZÁRLAT

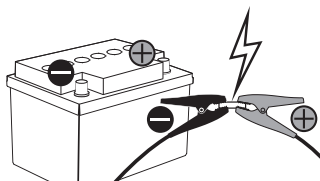

POLARITÁS FELCSERÉLÉSE

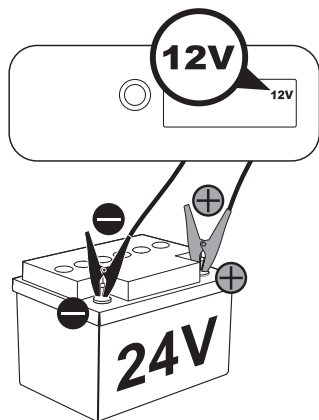
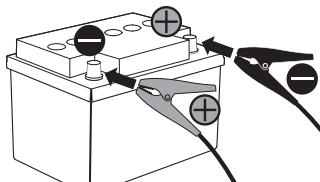

LED verzió

A TÖLTÉS/ MEGTARTÁS

PULSE-TRONIC TECHNOLOGIA



1 FESZÜLTÉG KIVÁLASZTÁSA

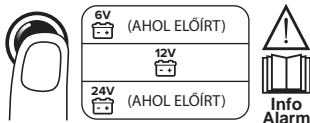

2 OPCIONÁLIS: HALADÓ MENÜ KIVÁLASZTÁSA



3 CSIPESZEK CSATLAKOZTATÁSA

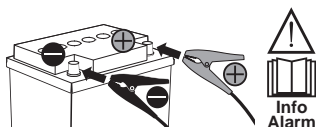

4 TÖLTÉS VÉGE - PÉLDA

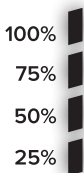

Pulse-Tronic töltés vége - Eredmény pozitív



Pulse-Tronic töltés vége - Eredmény negatív

C KARBANTARTÁS

RECOVERY

1 FESZÜLTÉG KIVÁLASZTÁSA

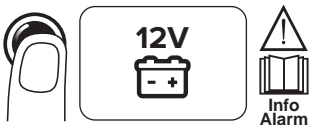

2 HALADÓ MENÜ KIVÁLASZTÁSA



3 CSIPESZEK CSATLAKOZTATÁSA

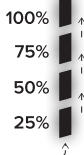
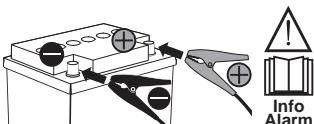

Egymásután felvillanó ledekkel jelzi azt, hogy a RECOVERY működés folyamatban van.

4 FOLYAMAT VÉGE - PÉLDA



5 KILÉPÉS A FUNKCIÓBÓL



D TÁPELLÁTÁS

SUPPLY

SUPPLY

AKKUMULÁTOR
CSERE

1 FESZÜLTÉG KIVÁLASZTÁSA



12V



Info
Alarm

2 HALADÓ MENÜ KIVÁLASZTÁSA



3"



SUPPLY

3 CSIPESZEK CSATLAKOZTATÁSA A JÁRMŰ AKKUMULÁTORÁNAK KÁBELEIHEZ

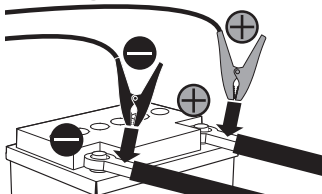

4 TÁPELLÁTOTT JÁRMŰ



AKKUMULÁTOR
ELTÁVOLÍTÁSA



AKKUMULÁTOR
CSERE

5 KILÉPÉS A FUNKCIÓBÓL



3"



RIASZTÁS
INFO



Info
Alarm



RÖVIDZÁRLAT

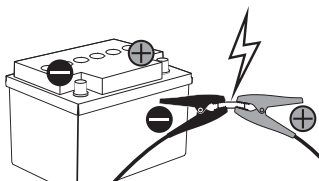

POLARITÁS FELCSERÉLÉSE

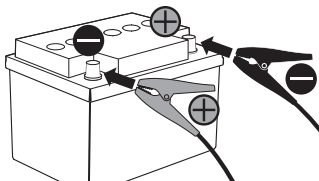

12V

12V



24V

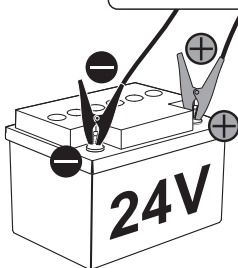

LCD versija (2 psl.)

1. Akumuliatoriaus įkrovos lygis.
2. Akumuliatoriaus tipo pasirinkimas:
 - **GEL:** švino-kalcio (PbCa) akumuliatoriai su želatiniu kietuoju elektrolitu, visiškai uždari. Šiems akumuliatoriams pastovi priežiūra yra nereikalinga.
 - **AGM (ABSORBENT GLASS MAT):** elektrolitu prisotinto stiklo pluošto akumuliatoriai. Visiškai uždari. Šiems akumuliatoriams pastovi priežiūra yra nereikalinga.
 - **AGM+:** užtikrina didesnę užvedimų skaičių esant didesnei srovei ir didesnį iškrovimo gylį nei standartiniai AGM akumuliatoriai. Idealiai tinka transporto priemonėms su „Start-Stop“ sistema. Mažesni gabaritai, didesnis atsparumas vibracijai ir trumpas įkrovimo laikas.
 - **Ličio (Li):** nedidelio svorio, didelio energijos tankio ir labai žemo savaiminio išsikrovimo akumuliatoriai. Dažniausiai jie yra naudojami sportinių automobilių pasaulyje.
 - **EFB (Enhanced Flooded Battery):** akumuliatoriai su skystuoju elektrolitu, pasižymintys geresniu įkrovimo efektyvumu bei galintys atlaikyti didesnę ciklą (paleidimų) skaičių, lyginant su paprastais tradiciniais akumuliatoriais. Idealiai tinka transporto priemonėms su „Start-Stop“ sistema.
3. Įkrovimas esant žemai temperatūrai (tinka ir WET akumuliatoriams).
4. Nustatyta akumuliatoriaus įtampa.
5. RECOVERY režimas. Papildoma funkcija sulfatacijos paveiktų akumuliatorių atstatymui.
6. Signalinis pranešimas apie poliškumo inversiją, trumpąjį sujungimą, susidėvėjusį arba sugedusį akumuliatorių.
7. SUPPLY režimas. Įtampos generatoriaus SUPPLY režimas. **Režimas neapsaugotas nuo poliškumo inversijos, trumpojo jungimo ar klaidingo įtampos pasirinkimo.**
8. Įkrovos PULSE-TRONIC fazės.
9. BOOST režimas. Papildoma funkcija greitam įkrovimui.
10. TEST režimas.
11. Generatoriaus testas ir Akumuliatoriaus startinio galingumo testas (CCA).
12. TEST, RECOVERY ir baigtos įkrovos rezultatai.
13. Nustatymų mygtukas:
 - PULSE-TRONIC ĮKROVIMAS (GEL, AGM, AGM +, Li, EFB ir įkrovimas žemos temperatūros sąlygomis ❄).
 - TEST (akumuliatoriaus būklė, akumuliatoriaus startinis galingumas, transporto priemonės generatorius).
 - Išplėstinės programos: BOOST, RECOVERY, SUPPLY.

LED versija (2 psl.)

1. Nustatymų mygtukas: Įkrovimo įtampos ir išplėstinių programų pasirinkimas.
2. Nustatyta akumuliatoriaus įtampa.
3. Akumuliatoriaus įkrovos lygis:
 - LED 25 % :** vyksta įkrovimas.
 - LED 50 % :** vyksta įkrovimas.
 - LED 75 % :** vyksta įkrovimas.
 - LED 100 % :** įkrovimo pabaiga.

4. Išplėstinės programos: **AGM** ❄. **RECOVERY, SUPPLY:**
 - **AGM** ❄
Funkcija yra naudinga **AGM** arba **WET** tipo akumuliatorių (hermetiški, švino rūgšties akumuliatoriai, su elektrolitą absorbuojančiu audiniu) įkrovimui arba įprastų akumuliatorių įkrovimui žemos temperatūros sąlygomis (žemesnėje nei 0°C temperatūroje) ❄.
 - **RECOVERY**
Papildoma funkcija sulfatacijos paveiktų akumuliatorių atstatymui.
 - **SUPPLY**
Įtampos generatoriaus SUPPLY režimas **Režimas neapsaugotas nuo poliškumo inversijos, trumpojo jungimo ar klaidingo įtampos pasirinkimo.**
5. Bendras signalinis pranešimas apie poliškumo inversiją, trumpąjį jungimą, susidėvėjusį arba sugedusį akumuliatorių.

FUNKCIJOS

- A. ĮKROVIMAS PULSE TRONIC
- B. TEST (jei numatytas)
 - ĮKROVIMO BŪSENOS TESTAS
 - AKUMULIATORIAUS STARTINIO GALINGUMO (CCA) TESTAS
 - GENERATORIAUS TESTAS
- C. AKUMULIATORIAUS TECHNINĖ PRIEŽIŪRA
 - RECOVERY
- D. SROVĖS TIEKIMAS
 - SUPPLY (jei numatytas)

PERSPĖJIMO SIGNALŲ INFORMACIJA

ĮKROVIMO KABELIŲ SUJUNGIMAS

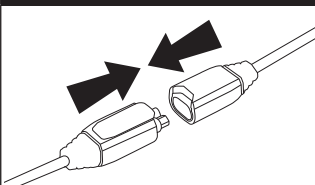

ĮJUNGIMAS

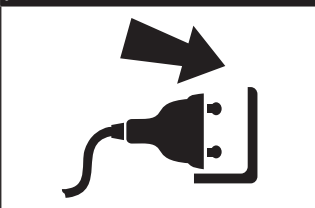

IŠJUNGIMAS

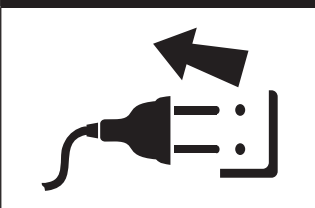

A ĮKROVIMAS/IŠLAIKYMAS

**PULSE-TRONIC
TECHNOLOGIJA**

- + - + - + - + - + - +
GEL AGM AGM+ Li EFB WET

1 ĮTAMPOS PASIRINKIMAS

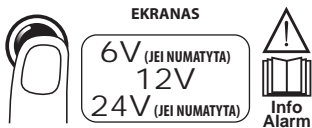

2 PROCESO PASIRINKIMAS Pulse-Tronic



3 PASIRENKAMAS PAPILDOMAI: IŠPLĖSTINIO MENIU PASIRINKIMAS



Pasirenkamas papildomai greitesniam įkrovimui

4 GNYBTŲ PRIJUNGIMAS

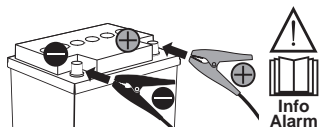

5 PULSE-TRONIC ĮKROVIMO FAZIŲ DIAGRAMA

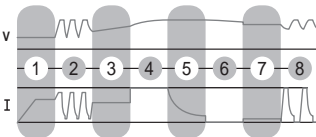

- 1 Akumuliatoriaus testavimas
- 2 Sulfatais apsinešusių/visiškai išsikrovusių akumuliatorių impulsinis atkūrimas
- 3 Vientisumo patikrinimas
- 4 Įkrova iki 80%
- 5 Įkrova iki 100%
- 6 Įkrovos išlaikymo stebėjimas
- 7 Įkrovos išlaikymas (*)
- 8 Įkrovos impulsais atstatymas (*)

(*) Išlaikymo etapai baigus įkrovimą. Jie nutraukiami atjungus akumuliatoriaus įkroviklį.

6 ĮKROVOS PABAIGA - PAVYZDYS



Pulse-Tronic įkrovos pabaiga- Rezultatas teigiamas



Pulse-Tronic įkrovos pabaiga- Rezultatas neigiamas

B TEST

ĮKROVOS BŪSENA



1 ĮTAMPOS PASIRINKIMAS



2 TESTO PASIRINKIMAS

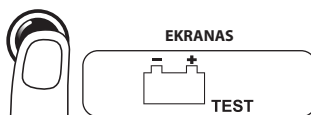

3 GNYBTŲ PRIJUNGIMAS

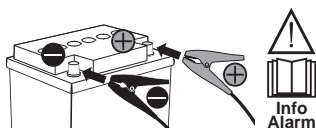

4 TESTO PABAIGA - PAVYZDYS



EKRANO SUTARTINIAI ŽENKLAI



B TEST

AKUMULIATORIAUS STARTINIS GALINGUMAS



1 ĮTAMPOS PASIRINKIMAS



2 TESTO PASIRINKIMAS

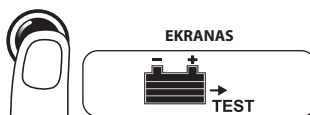

3 GNYBTŲ PRIJUNGIMAS

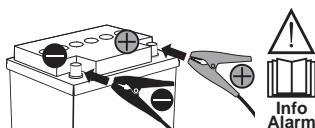

4 TRANSPORTO PRIEMONĖS PALEIDIMAS



5 TESTO PABAIGA - PAVYZDYS



EKRANO SUTARTINIAI ŽENKLAI



B TEST

GENERATORIUS



1 ĮTAMPOS PASIRINKIMAS



2 TESTO PASIRINKIMAS

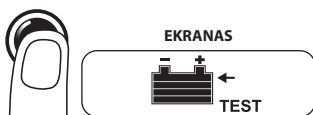

3 GNYBTŲ PRIJUNGIMAS

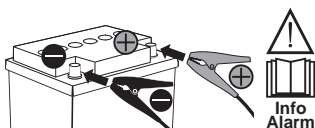

4 TRANSPORTO PRIEMONĖS PALEIDIMAS



5 TESTO PABAIGA - PAVYZDYS



EKRANO SUTARTINIAI ŽENKLAI



C TECHININĖ PRIEŽIŪRA

RECOVERY



1 ĮTAMPOS PASIRINKIMAS



2 IŠPLĖSTINIO MENIU PASIRINKIMAS



3 GNYBTŲ PRIJUNGIMAS

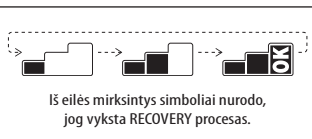
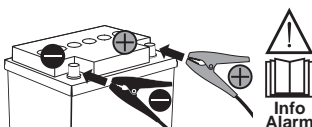

4 PROCESO PABAIGA - PAVYZDYS



5 IŠĖJIMAS IŠ FUNKCIJOS



D SROVĖS TIEKIMAS



PERSPĖJIMO SIGNALŲ
INFORMACIJA



Info
Alarm

SUPPLY

SUPPLY

AKUMULIATORIAUS
PAKEITIMAS

1 ĮTAMPOS PASIRINKIMAS



EKRANAS

12V



Info
Alarm

2 IŠPLĖSTINIO MENIU PASIRINKIMAS



EKRANAS

SUPPLY

3 GNYBTŲ PRIJUNGIMAS PRIE TRANSPORTO PRIEMONĖS AKUMULIATORIAUS LAIDŲ

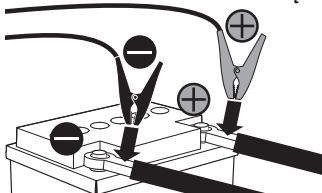

4 TRANSPORTO PRIEMONEI TIEKIAMA SROVĖ

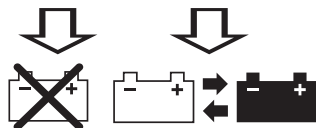

AKUMULIATORIAUS
AKUMULIATORIAUS
IŠĖMIMAS

PAKEITIMAS

5 IŠĖJIMAS IŠ FUNKCIJOS



3''



TRUMPAS SUJUNGIMAS

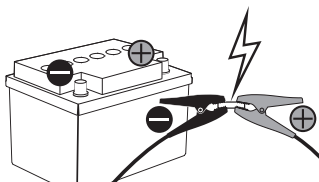

POLIŠKUMO SUKEITIMAS

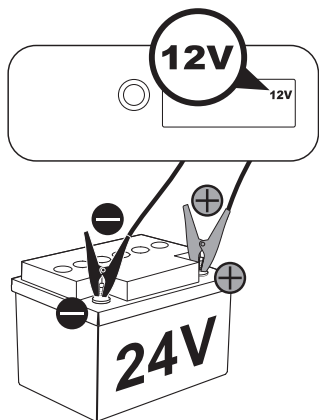
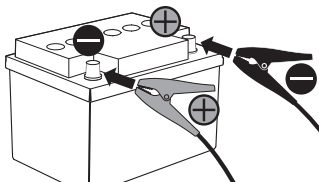

LED versija

A

ĮKROVIMAS/ IŠLAIKYMAS

PULSE-TRONIC TECHNOLOGIJA



1 ĮTAMPOS PASIRINKIMAS

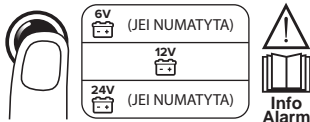

2 PASIRENKAMAS PAPILDOMAI: IŠPLĚSTINIO MENIU PASIRINKIMAS



3 GNYBTŲ PRIJUNGIMAS

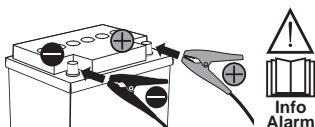

4 ĮKROVOS PABAIGA - PAVYZDYS



Pulse-Tronic įkrovos pabaiga- Rezultatas teigiamas



Pulse-Tronic įkrovos pabaiga- Rezultatas neigiamas

C

TECHNINĖ PRIEŽIŪRA

RECOVERY



1 ĮTAMPOS PASIRINKIMAS

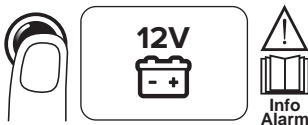

2 IŠPLĚSTINIO MENIU PASIRINKIMAS



3 GNYBTŲ PRIJUNGIMAS

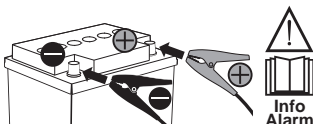

Paeiliui mirksinčios LED lemputės nurodo, jog vyksta RECOVERY procesas.

4 PROCESO PABAIGA - PAVYZDYS



5 IŠĖJIMAS IŠ FUNKCIJOS



3"

D SROVĖS TIEKIMAS



PERSPĖJIMO SIGNALŲ
INFORMACIJA



Info
Alarm

SUPPLY SUPPLY

AKUMULIATORIAUS
PAKEITIMAS

1 ĮTAMPOS PASIRINKIMAS



12V



Info
Alarm

2 IŠPLĖSTINIO MENIU PASIRINKIMAS



3"



SUPPLY

3 GNYBTŲ PRIJUNGIMAS PRIE TRANSPORTO PRIEMONĖS AKUMULIATORIAUS LAIDŲ

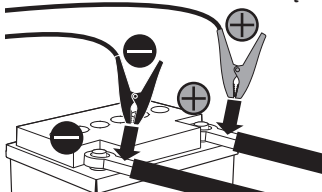

4 TRANSPORTO PRIEMONEI TIEKIAMA SROVĖ



AKUMULIATORIAUS
AKUMULIATORIAUS
IŠĖMIMAS



PAKEITIMAS

5 IŠĖJIMAS IŠ FUNKCIJOS



3"



TRUMPAS SUJUNGIMAS

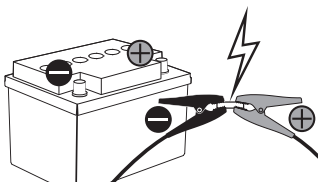

POLIŠKUMO SUKEITIMAS

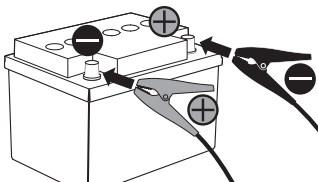

12V

12V



24V

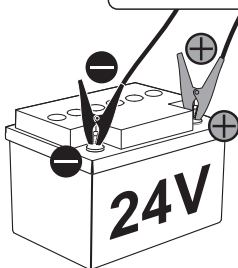

LCD versioon (lk. 2)

- Aku laetuse tase.
- Aku tüübi valik:
 - **GEEL:** hermeetiliselt suletud geelitaolise tahke elektrolüüdiga plii-kaltsium (PbCa) akud. Need on hoolduseta akud.
 - **AGM (ABSORBENT GLASS MAT):** absorbeeritud klaaskiust elektrolüüdiga pliiakud. Hermeetiliselt suletud. Need on hoolduseta akud.
 - **AGM+:** tagavad rohkem suurema voolutugevuse ja suurema tühjendussügavusega käivitusi kui tavalised AGM-akud. Kasutatakse Start-Stop süsteemiga varustatud sõidukites. Väiksemõtmeline, parem vibratsioonitaluvus ja kiire laetus.
 - **Liitium (Li):** kergekaalulised, suure energiatiheduse ja ülimalda isetühjenemisega akud. Kasutatakse peamiselt motosportis.
 - **EFB (Enhanced Flooded Battery):** parema laadimisvõimsusega, vedela elektrolüüdiga akud, mis peavad vastu suuremale arvule (käivitus)süklitele, kui tavaakud. Sobivad ideaalselt Start-Stop süsteemiga varustatud sõidukitele.
- Laadimine madalatel temperatuuridel (sobib ka WET akudele).
- Seadistatud polaarsusega aku.
- Režiim RECOVERY. Lisafunktsioon sulfaaditud akude taastamiseks.
- Pöördpolaarsusest, lühisest, kulunud või riknenud akust tingitud üldalarm.
- Režiim SUPPLY. Pingegeneraatori SUPPLY režiim. **Režiim ei ole kaitstud pöördpolaarsuse, lühise ja vale pingevaliku eest.**
- Laadimisfaasid PULSE-TRONIC.
- Režiim BOOST. Kiirllaadimise lisafunktsioon.
- Režiim TEST.
- Generaatori test ja aku käivitusvõimsuse test (CCA).
- TESTI, RECOVERY ja laadimise lõpu tulem.
- Seadistusnupp:
 - PULSE-TRONIC LAADIMINE (GEEL, AGM, AGM +, Li, EFB ja madalad temperatuurid ❄).
 - TEST (aku seisund, aku käivitusvõimsus, sõiduki generaator).
 - Täiendatud programmid: BOOST, RECOVERY, SUPPLY.

LED versioon (lk. 2)

- Seadistusnupp: Laadimispinge valimine ja täiustatud programmid.
- Seadistatud polaarsusega aku.
- Aku laetuse tase:
 - Led 25% :** toimub laadimine.
 - Led 50% :** toimub laadimine.
 - Led 75% :** toimub laadimine.
 - Led 100% :** laadimine lõppenud.
- Täiustatud programmid: **AGM ❄, RECOVERY, SUPPLY:**
 - **AGM ❄**
See funktsioon sobib "AGM" või "WET" tüüpi akude laadimiseks: absorbeerival materjalil elektrolüüdiga suletud pliiakud

või üldaku laadimiseks madalatel temperatuuridel, alla 0°C ❄.

• RECOVERY

Lisafunktsioon sulfaaditud akude taastamiseks.

• SUPPLY

Pingegeneraatori SUPPLY režiim

Režiim ei ole kaitstud pöördpolaarsuse, lühise ja vale pingevaliku eest.

- Üldine häire pöördpolaarsuse, lühise, kulunud või vigase aku korral.

FUNKTSIOONID

- PULSE-TRONIC LAADIMINE
- TEST (kus on)
 - LAETUSE TEST
 - AKU KÄIVITUSVÕIMSUSE TEST (CCA)
 - VAHELDUVVOOLU GENERAATORI TEST
- AKUDE HOOLDUS
 - RECOVERY
- TOIDE
 - SUPPLY (kus on)

HÄIREINFO

LAADIMISKAABLITE ÜHENDAMINE

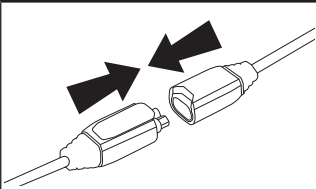

SISSELÜLITAMINE

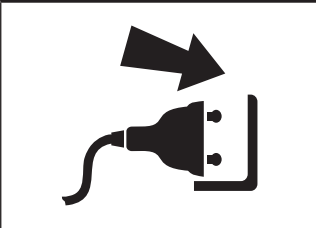

VÄLJALÜLITAMINE

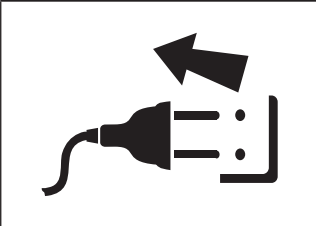

A LAADIMINE/HOIDMINE

PULSE-TRONIC TECHNOLOGY



1 PINGE VALIMINE

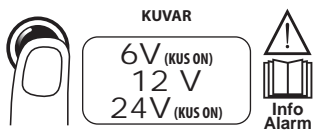

2 TÖÖ VALIMINE Pulse-Tronic

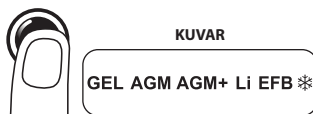

3 VALIKULINE: LISAMENÜÜ VALIMINE



Valikuline kiiremaks laadimiseks

4 KLEMMIDE ÜHENDAMINE

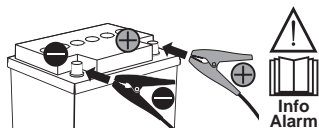

5 PULSE-TRONIC LAADIMISE FAASIDE GRAAFIK

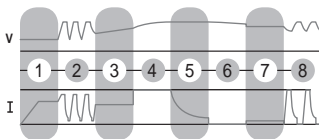

- 1 Akutest
- 2 Sulfaaditud/väga tühjade akude impulsslaadimine
- 3 Terviklikkuse kontroll
- 4 Laetus kuni 80%
- 5 Laetus kuni 100%
- 6 Laetuse monitor
- 7 Laetuse hoidmine (*)
- 8 Impulsslaadimise taastamine (*)

(*) Säilitusfaasid laadimise lõppedes.

Nende katkestamine toimub peale akulaadija lahtiühendamist.

6 LAADIMISE LÖPP - NÄIDE



Pulse-Tronic laadimise lõpp - Tulemus positiivne

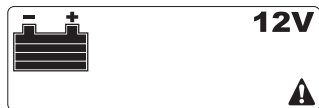

Pulse-Tronic laadimise lõpp - Tulemus negatiivne

B TEST

LAETUSE ASTE



1 PINGE VALIMINE



KUVAR

12V



2 TESTI VALIMINE



KUVAR



TEST

3 KLEMMIDE ÜHENDAMINE

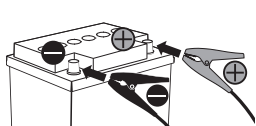

4 TESTI LÖPP - NÄIDE



TEST

12V

KUVARİ LEGEND



väga väike laetus



laadimata



laetud

B TEST

KÄIVITUSVÕIMSUS



1 PINGE VALIMINE



KUVAR

12V



2 TESTI VALIMINE



KUVAR

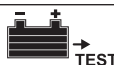

TEST

3 KLEMMIDE ÜHENDAMINE

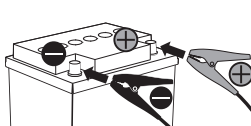

4 SÕIDUKI KÄIVITAMINE



5 TESTI LÖPP - NÄIDE



TEST

KUVARİ LEGEND



positiivne



piisav



negatiivne

B TEST

VAHELDUVVOOLU GENERAATOR



1 PINGE VALIMINE



KUVAR

12V



2 TESTI VALIMINE



KUVAR



TEST

3 KLEMMIDE ÜHENDAMINE

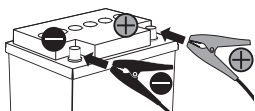

4 SÕIDUKI KÄIVITAMINE



5 TESTI LÖPP - NÄIDE

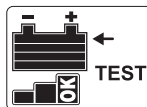

KUVARİ LEGEND



positiivne



piisav



negatiivne

C HOOLDUS

RECOVERY



1 PINGE VALIMINE



KUVAR

12V



2 LISAMENÜÜ VALIMINE



KUVAR



3"

3 KLEMMIDE ÜHENDAMINE

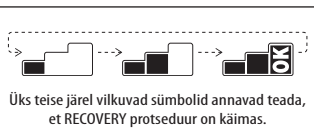
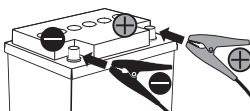

4 PROTSESSI LÖPP - NÄIDE



5 FUNKTSIOONIST VÄLJUMINE



3"

D TOIDE

SUPPLY

SUPPLY

VAHETUS
AKU

1 PINGE VALIMINE



KUVAR

12V



Info
Alarm

2 LISAMENÜÜ VALIMINE



KUVAR

SUPPLY

3"

3 KLEMMIDE ÜHENDAMINE SÕIDUKI AKU KAABLITEGA

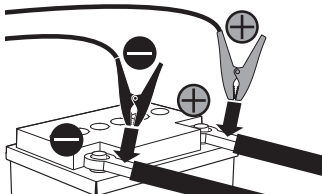

4 ENERGIATOITEGA VARUSTATUD SÕIDUK

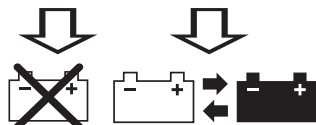

EEMALDAMINE
AKU

VÄLJVAHETAMINE
AKU

5 FUNKTSIOONIST VÄLJUMINE



3"



HÄIREINFO Info
Alarm



VOOLULÜHIS

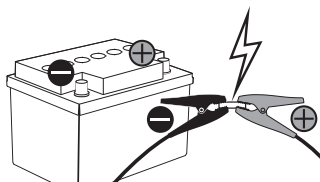

PÖÖRDPOLAARSUS

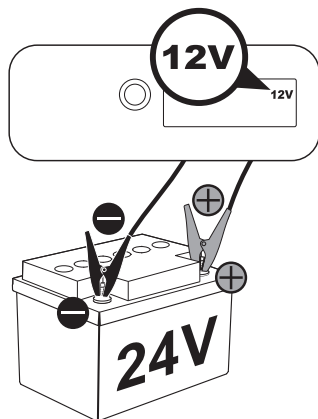
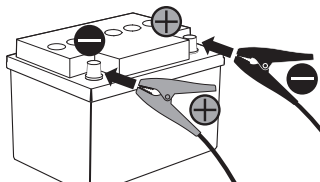

LED versioon

A

LAADIMINE HOIDMINE

PULSE-TRONIC TECHNOLOGY



1 PINGE VALIMINE

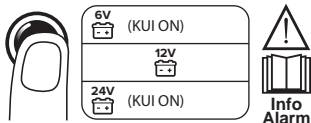

2 VALIKULINE: LISAMENÜÜ VALIMINE



3 KLEMMIDE ÜHENDAMINE

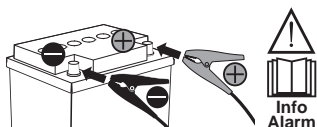

4 LAADIMISE LÕPP - NÄIDE



Pulse-Tronic laadimise lõpp - Tulemus positiivne



Pulse-Tronic laadimise lõpp - Tulemus negatiivne

C

HOOLDUS

RECOVERY



1 PINGE VALIMINE

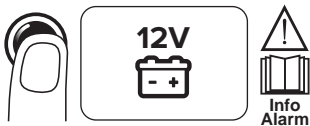

2 LISAMENÜÜ VALIMINE



3 KLEMMIDE ÜHENDAMINE

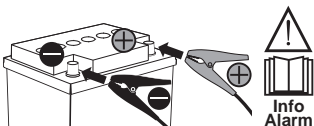

4 PROTSESSI LÕPP - NÄIDE



Järjestikku vilkuvate LED-idega antakse märku et RECOVERY protseduur on käimas.

5 FUNKTSIOONIST VÄLJUMINE



D TOIDE

SUPPLY

SUPPLY

VAHETUS
AKU

1 PINGE VALIMINE



12V



Info
Alarm

2 LISAMENÜÜ VALIMINE



3"



SUPPLY

3 KLEMMIDE ÜHENDAMINE SÕIDUKI AKU KAABLITEGA

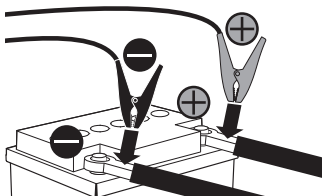

4 ENERGIATOITEGA VARUSTATUD SÕIDUK



EEMALDAMINE
AKU



VÄLJAVAHETAMINE
AKU



5 FUNKTSIOONIST VÄLJUMINE



3"



HÄIREINFO Info
Alarm



VOOLULÜHIS

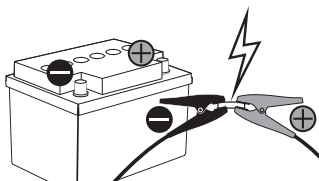

PÖÖRDPOLAARSUS

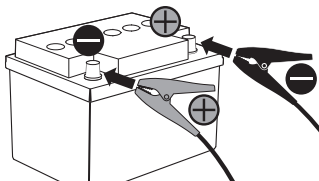

12V

12V



24V

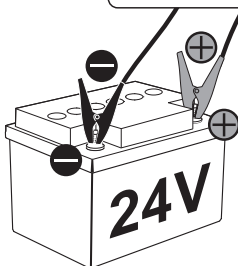

LCD versija (2. lpp.)

- Akumulatora uzlādes līmenis.
- Akumulatora tipa izvēle:
 - GEL:** pilnībā hermētiski svina-kalcija (PbCa) akumulatori ar cietu želejveida elektrolītu. Šiem akumulatoriem nav vajadzīga apkope.
 - AGM (ABSORBENT GLASS MAT):** svina akumulatori ar stikla šķiedrā absorbētu elektrolītu. Pilnībā hermētisks. Šiem akumulatoriem nav vajadzīga apkope.
 - AGM+:** nodrošina lielāku iedarbināšanas reižu skaitu ar lielāku strāvu un lielāku izlādes dziļumu, nekā standarta AGM. Izmanto transportlīdzekļos, kas aprīkoti ar Start-Stop sistēmu. Mazs izmērs, augstāka izturība pret vibrācijām un samazināts uzlādes laiks.
 - Litijs (Li):** baterijas ar mazu svaru, lielu enerģijas blīvumu un ļoti zemu pašizlādi. Tos galvenokārt izmanto autosporta pasaulē.
 - EFB (Enhanced Flooded Battery):** akumulatori ar šķidro elektrolītu un labākām atkārtotas uzlādes spējām, kas nodrošina lielāku ciklu (iedarbināšanas reižu) skaitu salīdzinājumā ar tradicionāliem akumulatoriem. Ideāli piemēroti transportlīdzekļiem, kas aprīkoti ar Start-Stop sistēmu.
- Uzlāde zemā temperatūrā (piemērota arī WET akumulatoriem).
- Iestatītais akumulatora spriegums.
- ATJAUNOŠANAS režīms. Papildu funkcija kas ļauj atjaunot sulfatētus akumulatorus.
- Vispārējs trauksmes signāls polaritātes neievērošanas, īssavienojuma, nodiluša vai bojāta akumulatora gadījumā.
- Režīms SUPPLY. Sprieguma ģenerators SUPPLY režīms. **Režīms nav aizsargāts pret polaritātes sajaukšanu, īssavienojumu un nepareizu sprieguma izvēli.**
- PULSE-TRONIC uzlādes posmi.
- Režīms BOOST. Papildu funkcija ātrai uzlādei.
- Režīms TEST.
- Ģenerators pārbaude un akumulatora palaišanas spējas pārbaude (CCA).
- TEST, RECOVERY rezultāts un uzlādes pabeigšana.
- Iestatīšanas poga:
 - UZLĀDE PULSE-TRONIC (GEL, AGM, AGM+, Li, EFB un zema temperatūra ❄).
 - TEST (akumulatora stāvoklis, akumulatora palaišanas spēja, transportlīdzekļa ģenerators).
 - Paplašinātas programmas: BOOST, RECOVERY, SUPPLY.

LED versija (2. lpp.)

- Iestatīšanas poga: Uzlādes sprieguma un paplašinātu programmu izvēle.
- Iestatītais akumulatora spriegums.
- Akumulatora uzlādes līmenis:
 - LED 25%:** notiek uzlāde.
 - LED 50%:** notiek uzlāde.
 - LED 75%:** notiek uzlāde.
 - LED 100%:** uzlāde pabeigta.
- Paplašinātas programmas: **AGM** ❄.

RECOVERY, SUPPLY:

• AGM ❄

Šo funkciju izmanto "AGM" vai "WET" tipa akumulatoru uzlādei: hermētiski svina akumulatori ar elektrolītu absorbējošā materiālā vai parastu akumulatoru uzlādei, ja temperatūra ir zemāka par 0°C ❄.

• RECOVERY

Papildu funkcija kas ļauj atjaunot sulfatētus akumulatorus.

• SUPPLY

Sprieguma ģenerators SUPPLY režīms **Režīms nav aizsargāts pret polaritātes sajaukšanu, īssavienojumu un nepareizu sprieguma izvēli.**

- Vispārējs trauksmes signāls polaritātes neievērošanas, īssavienojuma, nodiluša vai bojāta akumulatora gadījumā.

FUNKCIJAS

- UZLĀDE PULSE TRONIC
- TEST (ja paredzēts)
 - UZLĀDES STĀVOKĻA PĀRBAUDE
 - AKUMULATORA PALAIŠANAS SPĒJAS PĀRBAUDE (CCA)
 - ĢENERATORA PĀRBAUDE
- AKUMULATORU APKOPE
 - RECOVERY
- BAROŠANA
 - SUPPLY (ja paredzēts)

INFORMĀCIJA PAR TRAUKSMES SIGNĀLIEM

UZLĀDES KABEĻU PIESLĒGŠANA

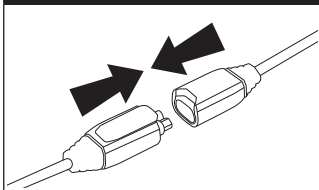

AIZDZEDZE

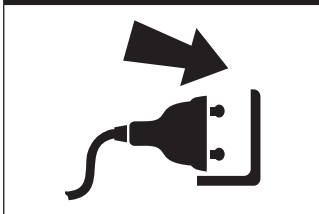

IZSLĒGŠANA

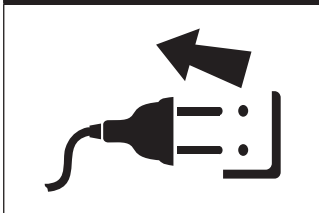

A UZLĀDĒŠANA/UZTURĒŠANA

PULSE-TRONIC TEHNOĻĪJA



1 SPRIEGUMA IZVĒLE

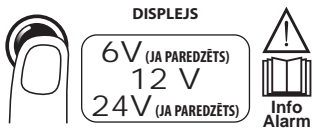

2 Pulse-Tronic REŽĪMA IZVĒLE

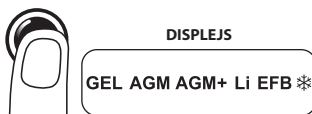

3 OPCIJA: PAPLAŠINĀTAS IZVĒLNES ATLAŠE



Opcija ātrākai uzlādei

4 SPAIĻU PIEVIEŅOŠANA

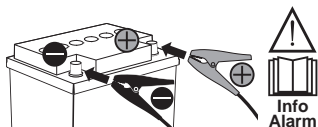

5 PULSE-TRONIC UZLĀDES POSMU GRAFIKS

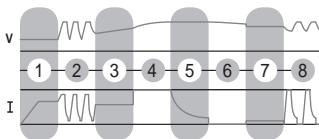

- 1 Akumulatora pārbaude
- 2 Sulfatācijai pakļautu/dzīļi izlādējušos akumulatoru impulsu atjaunošana
- 3 Integritātes pārbaude
- 4 Uzlāde līdz 80%
- 5 Uzlāde līdz 100%
- 6 Uzlādes uzturēšanas kontrole
- 7 Uzlādes uzturēšana (*)
- 8 Impulsu uzlādes atjaunošana (*)

(*) Uzturēšanas posms pēc uzlādes beigām. Tas tiek pārtraukts pēc akumulatoru lādētāja atvienošanas.

6 UZLĀDES PABEIGŠANA - PIEMĒRS



Pulse-Tronic uzlādes beigas – pozitīvs rezultāts

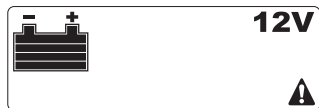

Pulse-Tronic uzlādes beigas – negatīvs rezultāts

B TEST

UZLĀDES STĀVOKLIS



1 SPRIEGUMA IZVĒLE



DISPLEJS

12V



2 PĀRBAUDES IZVĒLE



DISPLEJS



TEST

3 SPAIŅU PIEVIENOŠANA

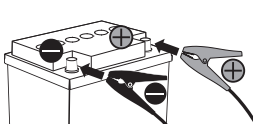

4 PĀRBAUDES PABEIGŠANA - PIEMĒRS



TEST

12V

APZĪMĒJUMI UZ DISPLEJA



ļoti izlādējies



izlādējies



uzlāde

B TEST

AKUMULATORA PALAIDES SPĒJA



1 SPRIEGUMA IZVĒLE



DISPLEJS

12V



2 PĀRBAUDES IZVĒLE



DISPLEJS



TEST

3 SPAIŅU PIEVIENOŠANA

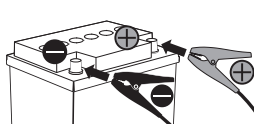

4 TRANSPORTLĪDZEKĻA IEDARBINĀŠANA



5 PĀRBAUDES PABEIGŠANA - PIEMĒRS



TEST

APZĪMĒJUMI UZ DISPLEJA



pozitivs



pietiekošs



negatīvs

B TEST

ĢENERATORS



1 SPRIEGUMA IZVĒLE



DISPLEJS

12V



2 PĀRBAUDES IZVĒLE



DISPLEJS



TEST

3 SPAIĻU PIEVIENOŠANA

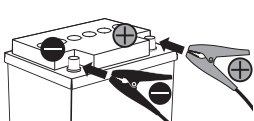

4 TRANSPORTLĪDZEKĻA IEDARBINĀŠANA



5 PĀRBAUDES PABEIGŠANA - PIEMĒRS

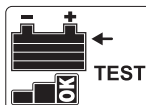

APZĪMĒJUMI UZ DISPLEJA



pozitivs



pietiekošs



negativs

C TEHNISKĀ APKOPE

RECOVERY



1 SPRIEGUMA IZVĒLE



DISPLEJS

12V



2 PAPLAŠINĀTAS IZVĒLNES ATLASE



DISPLEJS



3"

3 SPAIĻU PIEVIENOŠANA

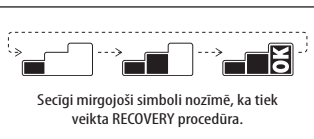
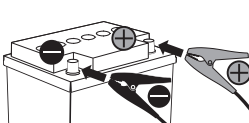

Secīgi mirgojoši simboli nozīmē, ka tiek veikta RECOVERY procedūra.

4 PROCESA PABEIGŠANA - PIEMĒRS



5 IZEJA NO FUNKCIJAS



3"

D BAROŠANA

BAROŠANAS
AVOTS

SUPPLY

AKUMULATORA
MAIŅA

1 SPRIEGUMA IZVĒLE



DISPLEJS

12V



Info
Alarm

2 PAPLAŠINĀTAS IZVĒLNES ATLASE



DISPLEJS

SUPPLY

3"

3 SPAIĻU PIEVIENOŠANA TRANSPORTLĪDZEKĻA AKUMULATORAM

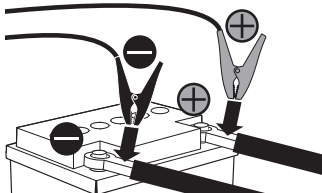

4 TRANSPORTLĪDZEKLIS TIEK BAROTS

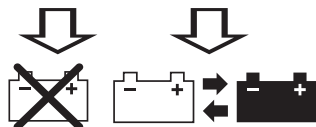

AKUMULATORA
IZŅEMŠANA

AKUMULATORA
NOMAĪNA

5 IZEJA NO FUNKCIJAS



3"



INFORMĀCIJA PAR
TRAUKSMES SIGNĀLIEM



Info
Alarm



ĪSSAVIENOJUMS

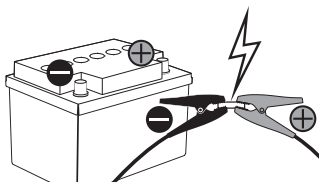

POLARITĀTES NIEIEVĒROŠANA

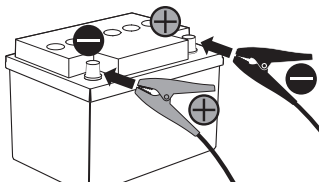

12V

12V

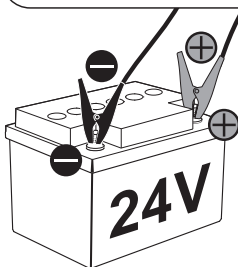

LED versija

A UZLĀDE/ UZTURĒŠANA

PULSE-TRONIC TEHNOĻĪJA



1 SPRIEGUMA IZVĒLE

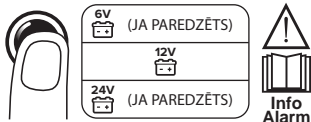

2 OPCIJA: PAPLAŠINĀTAS IZVĒLNES ATLASE



3 SPAIĻU PIEVIEŅOŠANA

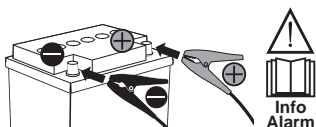

4 UZLĀDES PABEIGŠANA - PIEMĒRS



Pulse-Tronic uzlādes beigas – pozitīvs rezultāts



Pulse-Tronic uzlādes beigas – negatīvs rezultāts

C TEHNISKĀ APKOPE

RECOVERY



1 SPRIEGUMA IZVĒLE

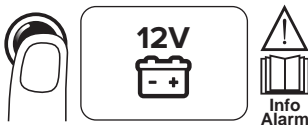

2 PAPLAŠINĀTAS IZVĒLNES ATLASE



3 SPAIĻU PIEVIEŅOŠANA

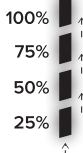
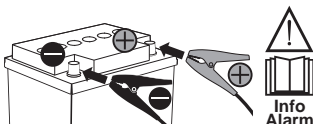

Sečīgi mirgojošas LED nozīmē, ka tiek veikta RECOVERY procedūra.

4 PROCESA PABEIGŠANA - PIEMĒRS



5 IZEJA NO FUNKCIJAS



D BAROŠANA

BAROŠANAS
AVOTS

SUPPLY

AKUMULATORA
MAIŅA

1 SPRIEGUMA IZVĒLE



12V



Info
Alarm

2 PAPLAŠINĀTAS IZVĒLNES ATLASE



3"



SUPPLY

3 SPAIĻU PIEVIENOŠANA TRANSPORTLĪDZEKĻA AKUMULATORAM

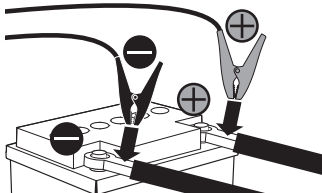

4 TRANSPORTLĪDZEKLIS TIEK BAROTS



AKUMULATORA
IZŅEMŠANA



AKUMULATORA
NOMAĪŅA

5 IZEJA NO FUNKCIJAS



3"



INFORMĀCIJA PAR
TRAUKSMES SIGNĀLIEM



Info
Alarm



ĪSSAVIENOJUMS

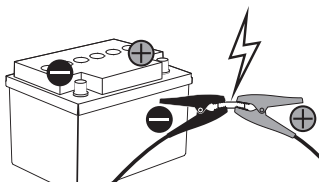

POLARITĀTES NIEIEVĒROŠANA

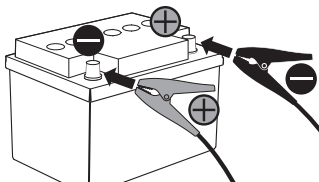

12V

12V



24V

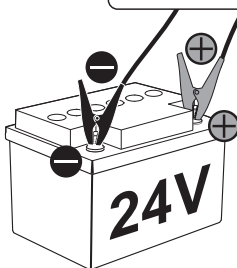

LCD версия (стр. 2)

1. Степен на зареждане на акумулатора.
2. Избор на типа акумулатор:
 - **GEL:** акумулатори, съдържащи олово и калций (PbCa) с твърд електролит от гелообразен напълно затворен тип. Тези акумулатори не изискват поддръжка.
 - **AGM (ABSORBENT GLASS MAT):** оловни акумулатори с електролит, абсорбиран на подложка от стъклена вата. Напълно затворен тип. Тези акумулатори не изискват поддръжка.
 - **AGM+:** осигуряват по-голям брой стартирания при по-висок ток и по-голяма дълбочина на разреждане в сравнение със стандартните AGM. Използват се в превозните средства, снабдени със система Start-Stop. С намалени размери, по-голяма устойчивост на вибрации и бързо време за зареждане.
 - **Литиеви (Li):** акумулатори с редуцирано тегло, висока енергийна плътност и много нисък саморазряд. Използват главно в света на моторните спортове.
 - **EFB (Enhanced Flooded Battery):** акумулатори с течен електролит с по-добър капацитет на зареждане, които поддържат по-голям брой цикли (стартирания) в сравнение с конвенционалните акумулатори. Идеални за превозни средства, снабдени със система Start-Stop.
3. Зареждане при ниски температури (препоръчано и за акумулатори WET).
4. Зададено напрежение на акумулатора.
5. Режим RECOVERY.
Допълнителна функция за възстановяване на сулфатизирани акумулатори.
6. Обща аларма за обръщане на полярността, късо съединение, изтощен или повреден акумулатор.
7. Режим SUPPLY.
Режим SUPPLY на генератора на напрежение.
Режимът не е защитен от обръщане на полярността, късо съединение и неправилен избор на напрежение.
8. Фази на зареждане PULSE-TRONIC.
9. Режим BOOST.
Допълнителна функция за бързо зареждане.
10. Режим TEST.
11. Тест алтернатор и Тест на капацитета за пускане на акумулатора (CCA).
12. Резултат от TEST, RECOVERY и край на зареждане.
13. Бутон за настройка:
 - ЗАРЕЖДАНЕ PULSE-TRONIC (GEL, AGM, AGM +, Li, EFB и ниски температури ❄).
 - TEST (състояние на акумулатора, капацитета за пускане на акумулатора, алтернатор на автомобила).
 - Усъвършенствани програми: BOOST, RECOVERY, SUPPLY.

LED версия (стр. 2)

1. Бутон за настройка:
Избор на напрежение за зареждане и усъвършенствани програми.
2. Зададено напрежение на акумулатора.
3. Степен на зареждане на акумулатора:
Led 25% : текущо зареждане.
Led 50% : текущо зареждане.
Led 75% : текущо зареждане.
Led 100% : край на зареждане.

4. Усъвършенствани програми: **AGM ❄**, **RECOVERY, SUPPLY:**
 - **AGM ❄**
Полезна функция за зареждане на акумулатори тип "AGM" или "WET": оловни акумулатори, които са запечатани, с електролит върху абсорбиращ материал или за зареждане на обикновени акумулатори в условия на ниски температури, под 0°C ❄.
 - **RECOVERY**
Допълнителна функция за възстановяване на сулфатизирани акумулатори.
 - **SUPPLY**
Режим SUPPLY на генератора на напрежение
Режимът не е защитен от обръщане на полярността, късо съединение и неправилен избор на напрежение.
5. Обща аларма за обръщане на полярността, късо съединение, изтощен или повреден акумулатор.

ФУНКЦИИ

- A. ЗАРЕЖДАНЕ PULSE-TRONIC
- B. TEST (където е предвидено)
 - ТЕСТ ЗА СТЕПЕНТА НА ЗАРЕЖДАНЕ
 - ТЕСТ НА КАПАЦИТЕТА ЗА ПУСКАНЕ НА АКУМУЛАТОРА (CCA)
 - ТЕСТ НА АЛТЕРНАТОРА
- C. ПОДДРЪЖКА НА АКУМУЛАТОРИТЕ
 - RECOVERY
- D. ЗАХРАНВАНЕ
 - SUPPLY (където е предвидено)

ИНФОРМАЦИЯ АЛАРМИ

СВЪРЗВАНЕ НА КАБЕЛИТЕ ЗА ЗАРЕЖДАНЕ

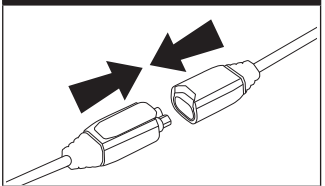

ПУСКАНЕ

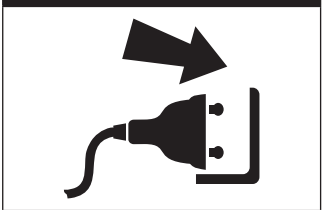

ИЗГАСВАНЕ

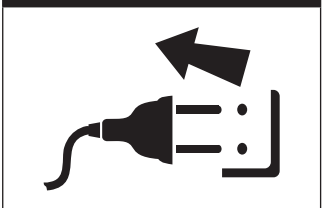

A ЗАРЕЖДАНЕ/ПОДДЪРЖАНЕ

ТЕХНОЛОГИЯ PULSE-TRONIC



1 ИЗБОР НА НАПРЕЖЕНИЕ

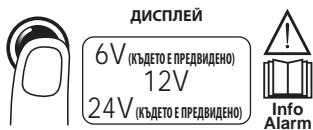

2 ИЗБОР НА ПРОЦЕС Pulse-Tronic



3 ОПЦИОНАЛНО: ИЗБОР НА УСЪВЪРШЕНСТВАНО МЕНЮ



Опционално за по-бързо зареждане

4 СВЪРЗВАНЕ НА ЩИПКИТЕ

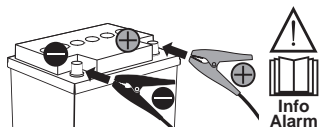

5 ГРАФИКА НА ФАЗИТЕ НА ЗАРЕЖДАНЕ PULSE-TRONIC

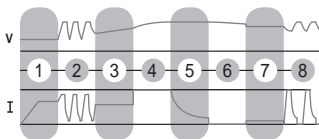

- 1 Тест на акумулатора
- 2 Импулсно възстановяване на сулфатизирани/силно изтощени акумулатори
- 3 Проверка на целостта
- 4 Зареждане на 80%
- 5 Зареждане на 100%
- 6 Мониторинг на поддържането на зареждане
- 7 Поддържане на зареждането (*)
- 8 Възстановяване на зареждането с импулси (*)

(*) Фази на поддържане след края на зареждането.

Прекъсването им става, след като сте изключили зарядното устройство.

6 КРАЙ НА ЗАРЕЖДАНЕТО - ПРИМЕР

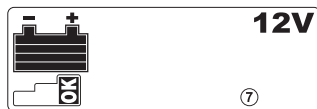

Край на зареждането Pulse-Tronic - Положителен резултат

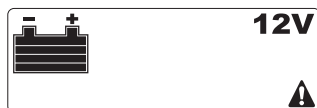

Край на зареждането Pulse-Tronic - Отрицателен резултат

B TEST

СТЕПЕН НА ЗАРЕЖДАНЕ



1 ИЗБОР НА НАПРЕЖЕНИЕ



2 ИЗБОР НА ТЕСТ

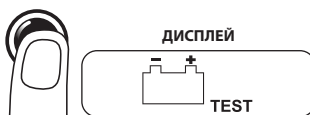

3 СВЪРЗВАНЕ НА ЩИПКИТЕ

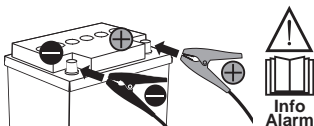

4 КРАЙ НА ТЕСТА - ПРИМЕР



ЛЕГЕНДА НА ДИСПЛЕЯ



B TEST

КАПАЦИТЕТ ЗА ПУСКАНЕ НА АКУМУЛАТОРА



1 ИЗБОР НА НАПРЕЖЕНИЕ



2 ИЗБОР НА ТЕСТ



3 СВЪРЗВАНЕ НА ЩИПКИТЕ

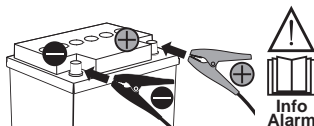

4 ПУСКАНЕ НА АВТОМОБИЛА



5 КРАЙ НА ТЕСТА - ПРИМЕР



ЛЕГЕНДА НА ДИСПЛЕЯ



B TEST

АЛТЕРНАТОР



1 ИЗБОР НА НАПРЕЖЕНИЕ



2 ИЗБОР НА ТЕСТ



3 СВЪРЗВАНЕ НА ЩИПКИТЕ

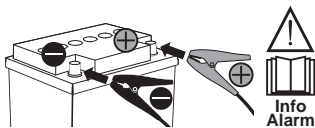

4 ПУСКАНЕ НА АВТОМОБИЛА



5 КРАЙ НА ТЕСТА - ПРИМЕР



ЛЕГЕНДА НА ДИСПЛЕЯ



C ПОДДРЪЖКА

RECOVERY



1 ИЗБОР НА НАПРЕЖЕНИЕ



2 ИЗБОР НА УСЪВЪРШЕНСТВАНО МЕНЮ



3 СВЪРЗВАНЕ НА ЩИПКИТЕ

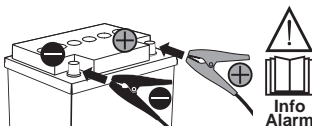

4 КРАЙ НА ПРОЦЕСА - ПРИМЕР



5 ИЗХОД ОТ ФУНКЦИЯТА



D ЗАХРАНВАНЕ

SUPPLY

SUPPLY

СМЯНА
АКУМУЛАТОР

1 ИЗБОР НА НАПРЕЖЕНИЕ



ДИСПЛЕЙ

12V



Info
Alarm

2 ИЗБОР НА УСЪВЪРШЕНСТВАНО МЕНЮ



ДИСПЛЕЙ

SUPPLY

3"

3 СВЪРЗВАНЕ НА ЩИПКИТЕ С КАБЕЛИТЕ НА АКУМУЛАТОРА НА АВТОМОБИЛА

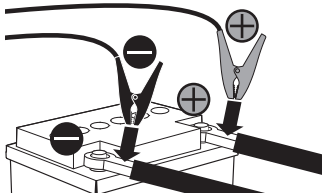

4 ЗАХРАНВАН АВТОМОБИЛ

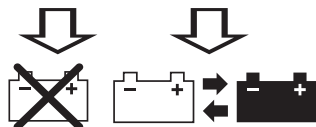

ПРЕМАХВАНЕ
АКУМУЛАТОР

ЗАМЯНА
АКУМУЛАТОР

5 ИЗХОД ОТ ФУНКЦИЯТА



3"



ИНФОРМАЦИЯ
АЛАРМИ



Info
Alarm



КЪСО СЪЕДИНЕНИЕ

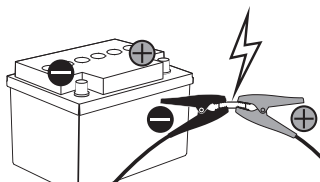

ОБРЪЩАНЕ НА ПОЛЯРНОСТТА

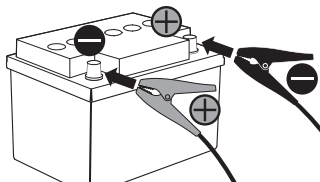

12V

12V

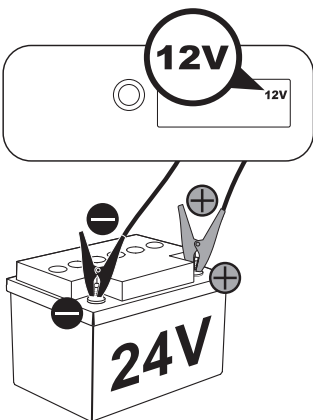

LED версия

A ЗАРЕЖДАНЕ/ ПОДДРЪЖКА

ТЕХНОЛОГИЯ PULSE-TRONIC



1 ИЗБОР НА НАПРЕЖЕНИЕ

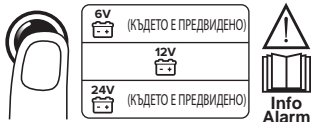

2 ОПЦИОНАЛНО: ИЗБОР НА УСЪВЪРШЕНСТВАНО МЕНЮ



3 СВЪРЗВАНЕ НА ЩИПКИТЕ

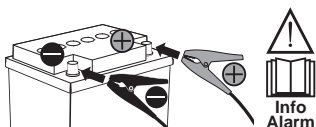

4 КРАЙ НА ЗАРЕЖДАНЕТО - ПРИМЕР

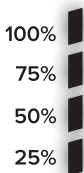

Край на зареждането Pulse-Tronic -
Положителен резултат



Край на зареждането Pulse-Tronic -
Отрицателен резултат

C ПОДДРЪЖКА

RECOVERY

1 ИЗБОР НА НАПРЕЖЕНИЕ

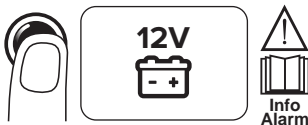

2 ИЗБОР НА УСЪВЪРШЕНСТВАНО МЕНЮ



3 СВЪРЗВАНЕ НА ЩИПКИТЕ

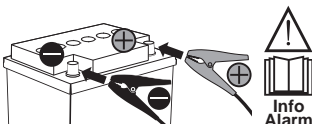

С последователно мигачи светодиоди се означава, че текущо се изпълнява процесът RECOVERY.

4 КРАЙ НА ПРОЦЕСА - ПРИМЕР



5 ИЗХОД ОТ ФУНКЦИЯТА



D ЗАХРАНВАНЕ



ИНФОРМАЦИЯ
АЛАРМИ



SUPPLY

SUPPLY

СМЯНА
АКУМУЛАТОР

1 ИЗБОР НА НАПРЕЖЕНИЕ



12V



Info
Alarm

2 ИЗБОР НА УСЪВЪРШЕНСТВАНО МЕНЮ



SUPPLY

3"

3 СВЪРЗВАНЕ НА ЩИПКИТЕ С КАБЕЛИТЕ НА АКУМУЛАТОРА НА АВТОМОБИЛА

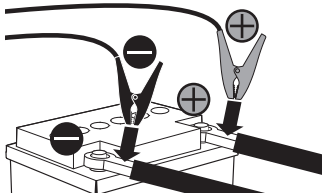

4 ЗАХРАНВАН АВТОМОБИЛ



ПРЕМАХВАНЕ
АКУМУЛАТОР



ЗАМЯНА
АКУМУЛАТОР

5 ИЗХОД ОТ ФУНКЦИЯТА



3"



КЪСО СЪЕДИНЕНИЕ

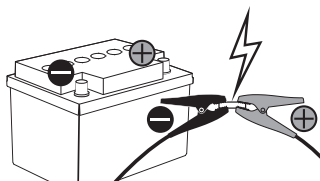

ОБРЪЩАНЕ НА ПОЛЯРНОСТТА

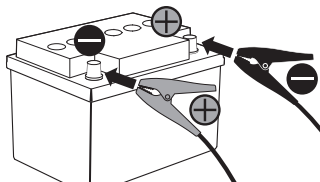

12V

12V



24V

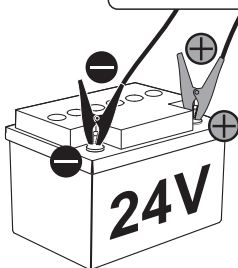

LCD versiyonu (Sf. 2)

- Akü şarj seviyesi.
- Akü tipinin seçimi:
 - **JEL:** tamamen mühürlenmiş, jel tipi katı elektrolitli Kurşun-Kalsiyum (PbCa) aküler. Bu aküler bakım gerektirmez.
 - **AGM (ABSORBENT GLASS MAT-EMİCİ CAM YASTIK):** cam elyafına emdirilmiş elektrolitli Kurşun aküler. Tamamen mühürlenmiştir. Bu aküler bakım gerektirmez.
 - **AGM+:** standart AGM'lerden daha yüksek bir akımda daha fazla sayıda başlatma ve daha yüksek bir deşarj derinliği sağlarlar. Start-Stop sistemi ile donatılmış araçlarda kullanılır. Küçük boyutlar, daha yüksek titreşim direnci ve hızlı yeniden şarj süreleri.
 - **Lityum (Li):** düşük ağırlık, yüksek enerji yoğunluğu ve kendi kendine deşarj oranı çok düşük aküler. Özellikle motor sporları dünyasında kullanılırlar.
 - **EFB (Enhanced Flooded Battery-Geliştirilmiş Islak Tip Akü):** daha iyi yeniden şarj kapasitesine sahip ve geleneksel olanlardan daha fazla sayıda çevrimi (başlatma) destekleyen sıvı elektrolit aküler. Start-Stop sistemi ile donatılmış araçlar için idealdir.
- Düşük sıcaklıklarda şarj (WET-SULU aküler için de uygundur).
- Akünün ayarlanmış gerilimi.
- RECOVERY modu. Sülfatlaşmış aküleri kurtarmak için ilave fonksiyon.
- Ters kutup, kısa devre, aşınmış veya arızalı akü nedeni genel çerçeveli alarm.
- SUPPLY Modu. SUPPLY Modu gerilim jeneratörü. **Ters kutup, kısa devre ve hatalı gerilim seçimine karşı korunmayan mod.**
- PULSE-TRONIC şarj fazları.
- BOOST Modu. Hızlı şarj için ilave işlev.
- TEST Modu.
- Alternatör testi ve Akü çalışma kapasitesi testi (CCA).
- TEST, RECOVERY- KURTARMA ve şarj sonu sonucu.
- Ayarlama butonu:
 - PULSE-TRONIC ŞARJ (JEL, AGM, AGM +, Li, EFB ve düşük sıcaklıklar ❄).
 - TEST (akü durumu, akü başlatma kapasitesi, araç alternatörü).
 - Gelişmiş Programlar: BOOST, RECOVERY, SUPPLY.

LED versiyonu (Sf. 2)

- Ayarlama butonu: Şarj geriliminin ve gelişmiş programların seçimi.
- Akünün ayarlanmış gerilimi.
- Akü şarj seviyesi:
 - Led %25 :** şarj devam ediyor.
 - Led %50 :** şarj devam ediyor.
 - Led %75 :** şarj devam ediyor.
 - Led %100 :** şarj sonu.
- Gelişmiş Programlar: **AGM ❄, RECOVERY, SUPPLY:**
 - **AGM ❄**
"AGM" veya "WET" tipi bir aküyü şarj etmek için faydalı fonksiyon: kurşun asit

aküler, mühürlü, emici materyal üzerinde elektrolit ile veya 0°C altında, düşük sıcaklık şartlarında ❄ genel çerçeveli bir aküyü şarj etmek için kullanılır.

• **RECOVERY**

Sülfatlaşmış aküleri kurtarmak için ilave fonksiyon.

• **SUPPLY**

SUPPLY Modu gerilim jeneratörü

Ters kutup, kısa devre ve hatalı gerilim seçimine karşı korunmayan mod.

- Ters kutup, kısa devre, aşınmış veya arızalı akü nedeni genel çerçeveli alarm.

FONKSİYONLAR

- PULSE-TRONIC ŞARJ
- TEST (öngörülen yerlerde)
 - ŞARJ DURUM TESTİ
 - AKÜ ÇALIŞTIRMA KAPASİTE TESTİ (CCA)
 - ALTERNATÖR TESTİ
- AKÜLERİN BAKIMI
 - RECOVERY - KURTARMA
- BESLEME
 - SUPPLY (öngörülen yerlerde)

INFO ALARMLAR

ŞARJ KABLOLARININ BAĞLANMASI

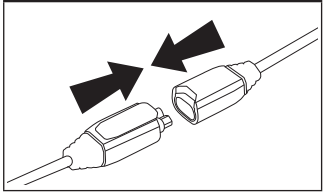

AÇMA



KAPAMA

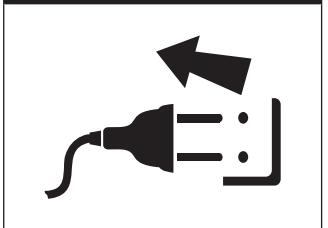

A ŞARJ/ŞARJ MUHAFAZASI

PULSE-TRONIC TEKNOLOJİSİ



1 GERİLİM SEÇİMİ



2 SÜREÇ SEÇİMİ Pulse-Tronic

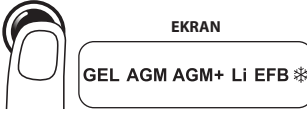

3 OPSİYONEL: GELİŞMİŞ MENÜ SEÇİMİ



Daha hızlı bir şarj için opsiyonel

4 MAŞALARIN BAĞLANMASI

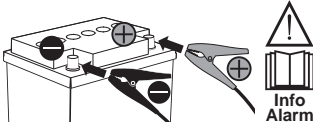

5 PULSE-TRONIC ŞARJ FAZLARI GRAFİĞİ

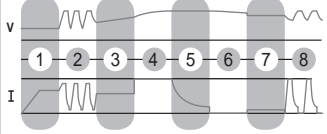

- 1 Akü Testi
- 2 Sülfatlanmış / çok boşalmış akülerin akım darbeleri uygulanarak geri kazanılması
- 3 Bütünlük kontrolü
- 4 %80'e kadar şarj
- 5 %100'E kadar şarj
- 6 Şarj tutma monitörü
- 7 Şarj muhafazası (*)
- 8 Darbeli şarj yeniden düzenleme (*)

(*) Şarj tamamlandıktan sonra muhafaza evreleri.

Bunların kesilmesi, şarj cihazı ayrıldıktan sonra gerçekleşir.

6 ŞARJ SONU - ÖRNEK



Pulse-Tronic şarj sonu- Olumlu sonuç



Pulse-Tronic şarj sonu- Olumsuz sonuç

B TEST

ŞARJ DURUMU



1 GERİLİM SEÇİMİ



2 TEST SEÇİMİ

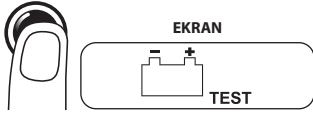

3 MAŞALARIN BAĞLANMASI

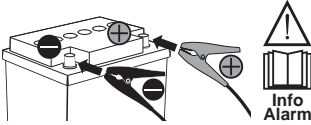

4 TEST SONU - ÖRNEK



EKRAN AÇIKLAMALARI

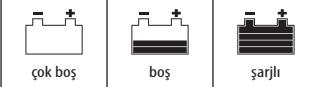

B TEST

AKÜ ÇALIŞTIRMA KAPASİTESİ



1 GERİLİM SEÇİMİ



2 TEST SEÇİMİ

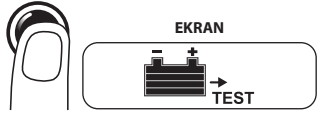

3 MAŞALARIN BAĞLANMASI

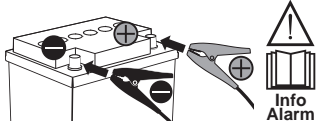

4 ARACIN BAŞLATILMASI



5 TEST SONU - ÖRNEK



EKRAN AÇIKLAMALARI

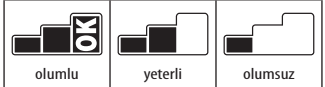

B TEST

ALTERNATÖR



1 GERİLİM SEÇİMİ



2 TEST SEÇİMİ

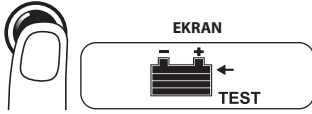

3 MAŞALARIN BAĞLANMASI

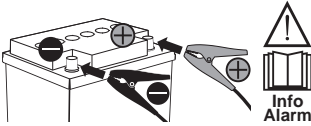

4 ARACIN BAŞLATILMASI



5 TEST SONU - ÖRNEK



EKRAN AÇIKLAMALARI

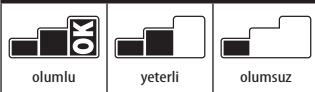

C BAKIM

RECOVERY



1 GERİLİM SEÇİMİ



2 GELİŞMİŞ MENÜ SEÇİMİ



3 MAŞALARIN BAĞLANMASI

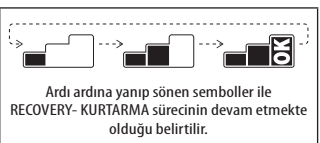
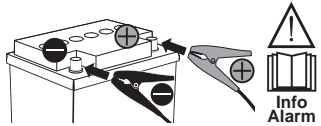

4 SÜREÇ SONU - ÖRNEK



5 FONKSİYONDAN ÇIKIŞ



D BESLEME

SUPPLY SUPPLY

AKÜ DEĞİŞİMİ

1 GERİLİM SEÇİMİ



EKRAN

12V



Info Alarm

2 GELİŞMİŞ MENÜ SEÇİMİ



EKRAN

SUPPLY

3"

3 MAŞALARIN ARAÇ AKUSÜNÜN KABLOLARINA BAĞLANMASI

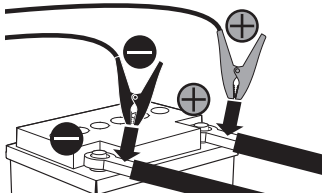

4 BESLENEN ARAÇ



AKÜ AKÜ
ÇIKARMA



DEĞİŞTİRME

5 FONKSİYONDAN ÇIKIŞ



3"



INFO ALARMLAR Info Alarm



KISA DEVRE

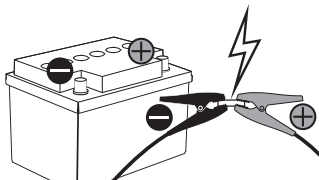

TERS KUTUP

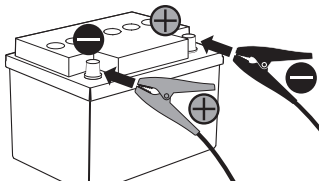

12V

12V

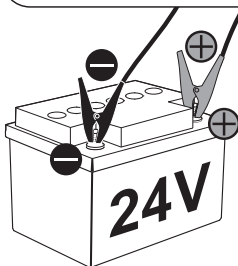

LED versiyonu

A

ŞARJ/ŞARJ MUHAFAZASI

PULSE-TRONIC TEKNOLOJİSİ



1 GERİLİM SEÇİMİ

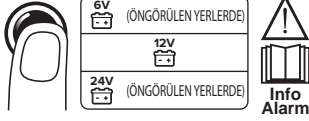

2 OPSİYONEL: GELİŞMİŞ MENÜ SEÇİMİ



3 MAŞALARIN BAĞLANMASI

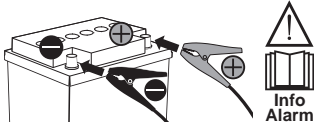

4 ŞARJ SONU - ÖRNEK



Pulse-Tronic şarj sonu- Olumlu sonuç



Pulse-Tronic şarj sonu- Olumsuz sonuç

C

BAKIM

RECOVERY



1 GERİLİM SEÇİMİ



2 GELİŞMİŞ MENÜ SEÇİMİ



3 MAŞALARIN BAĞLANMASI

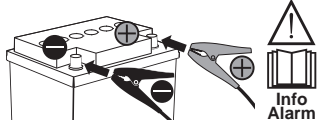

Ardı ardına yanıp sönen ledler ile RECOVERY-KURTARMA sürecinin devam etmekte olduğu belirtilir.

4 SÜREÇ SONU - ÖRNEK



5 FONKSİYONDAN ÇIKIŞ



D BESLEME

SUPPLY SUPPLY

AKÜ DEĞİŞİMİ

1 GERİLİM SEÇİMİ



12V



Info Alarm

2 GELİŞMİŞ MENÜ SEÇİMİ



3"

SUPPLY

3 MAŞALARIN ARAÇ AKUSÜNÜN KABLOLARINA BAĞLANMASI

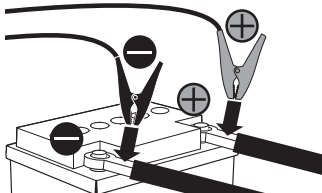

4 BESLENEN ARAÇ



AKÜ AKÜ ÇIKARMA



DEĞİŞTİRME

5 FONKSİYONDAN ÇIKIŞ



3"



INFO ALARMLAR Info Alarm



KISA DEVRE

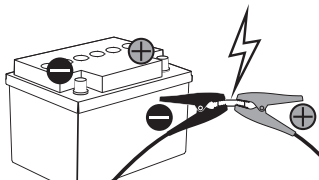

TERS KUTUP

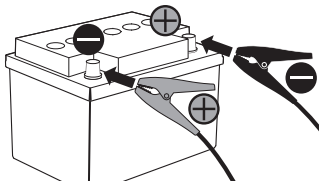

12V

12V



24V

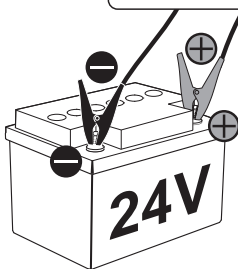

المؤشر الضوئي 100%: إكمال الشحن.
4. برامج متقدمة: AGM*، التعافي، الامداد:

AGM*

وظيفة مفيدة لشحن بطارية من نوع "AGM" أو "WET": بطاريات تعمل بالريصاص، محكمة الغلق مع المنحل بالكهرباء على مادة ماصة أو لشحن بطارية عامة في ظل درجة حرارة منخفضة أقل من 0 درجة مئوية

RECOVERY*

الوظيفة الإضافية لاستعادة البطاريات المكترية.

SUPPLY*

طريقة الامداد لمولد الجهد

وضعية بدون حماية بسبب عكس الاقطاب، ماس كهربائي واختيار خاطئ للجهد.

5. تحذير عام لإستبدال الاقطاب، الدائرة القصيرة، بطارية متهاكلة أو تالفة.

الوظائف

أ. الشحن بالنابض الإلكتروني
ب. TEST (إذا كان وارداً)

- اختبار حالة الشحن
- اختبار قدرة بدء تشغيل البطارية (CCA)
- اختبار المبادل

ت. صيانة البطارية

- التعافي

ث. التغذية

- SUPPLY (إذا كان وارداً)

معلومات عن التحذيرات

توصيل كابلات الشحن

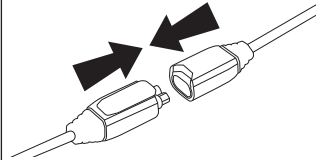

التشغيل

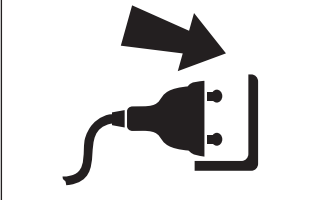

الاطفاء

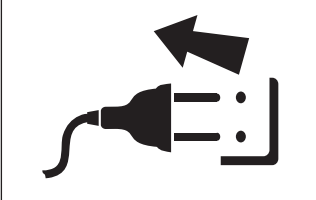

1. مستوى شحن البطارية.
2. اختيار نوع البطارية:

• GEL: بطاريات تعمل بالريصاص-الكالسيوم (PbCa) ذات التوصيل الكهربائي الصلب من النوع الجيلاتيني المحكمة الغلق تماماً. وهي بطاريات ليس لها صيانة.

• AGM (ABSORBENT GLASS MAT) حصيرة زجاجية ماصة: بطاريات تعمل بالريصاص ذات انحلال الكهربياء الممتصة في فيبر زجاجي. محكمة الغلق تماماً. وهي بطاريات ليس لها صيانة.

• AGM+: تتضمن عدد أكبر من عمليات بدء التشغيل مع تيار أقوى ودرجة شحن منخفضة أكبر من AGM القياسية. مستخدمة في المركبات المزودة بنظام التوقف-التحرك. حجم أقل، مقاومة أعلى للذبذبات ووقت شحن سريع.

• بطارية بالليثيوم (Li): بطاريات منخفضة الوزن، عالية الكثافة بالطاقة وذات معدل انخفاض كبير في التفريغ الذاتي من الشحن. تستخدم بشكل أساسي في عالم المحركات الرياضية.

• EFB (Enhanced Flooded Battery): بطارية مغمورة محسنة: بطارية بسائل منحل بالكهرباء مع قدرة شحن أفضل وتحمل كمية دورات (بدء تشغيل) أعلى من تلك التقليدية. مثالية لمركبات مزودة بنظام التوقف-التحرك.

3. شحن بدرجة حرارة منخفضة (ينصح به أيضاً بالنسبة للبطاريات WET).

4. جهد البطارية المعد مسبقاً.

5. وضعية التعافي.

الوظيفة الإضافية لاستعادة البطاريات المكترية.

6. تحذير عام لإستبدال الاقطاب، الدائرة القصيرة، بطارية متهاكلة أو تالفة.

7. طريقة الامداد.

طريقة الامداد لمولد الجهد.

وضعية بدون حماية بسبب عكس الاقطاب، ماس كهربائي واختيار خاطئ للجهد.

8. مراحل الشحن PULSE-TRONIC.

9. وضعية BOOST.

وظيفة إضافية للشحن السريع.

10. وضعية TEST.

11. اختبار المبادل واختبار قدرة بدء تشغيل البطارية (CCA).

12. نتيجة الاختبار، التعافي ونهاية الشحن.

13. زر الإعدادات:

- طريقة الشحن PULSE-TRONIC (GEL و AGM و AGM+ و Li و EFB و درجات حرارة منخفضة).

- اختبار (حالة البطارية، قدرة بدء تشغيل البطارية، مبادل المركبة).

- برامج متقدمة: التعزيز، التعافي، الامداد.

نسخة LED (صفحة 2)

1. زر الإعدادات:

اختيار جهد الشحن والبرامج المتقدمة.

2. جهد البطارية المعد مسبقاً.

3. مستوى شحن البطارية:

المؤشر الضوئي 25%: جاري الشحن.

المؤشر الضوئي 50%: جاري الشحن.

المؤشر الضوئي 75%: جاري الشحن.



5 رسم بياني لمراحل الشحن بالناض-الالكتروني

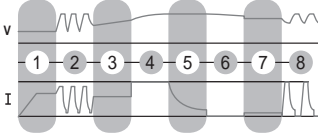

- 1 اختبار على البطارية
 - 2 استعادة دفعات بطاريات مفسفرة/ فارغة للغاية
 - 3 التحقق من التكامل
 - 4 الشحن حتى 80%
 - 5 الشحن حتى 100%
 - 6 شاشة الحفاظ على الشحن
 - 7 الحفاظ على الشحن (*)
 - 8 استعادة شحن بالنبضات (*)
- (*) مراحل الحفاظ بعد انتهاء الشحن.
توقف بعد فصل شاحن البطاريات.

6 نهاية الشحن - مثال



نهاية الشحن PULSE-TRONIC - نتيجة إيجابية



نهاية الشحن PULSE-TRONIC - نتيجة سلبية

1 اختيار الجهد



شاشة
6 فولت (إن وجدت)
12 فولت
24 فولت (إذا كان وارداً)



2 اختيار المجريات الناض الكتروني

شاشة
GEL AGM AGM+ Li EFB *



3 إختياري: اختيار قائمة الاختيارات المتقدمة

شاشة
BOOST



إختياري للحصول على شحن أسرع

4 توصيل المشابك

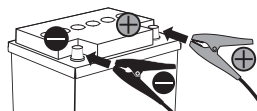

B اختبار

قدرة بدء تشغيل البطارية →

1 اختيار الجهد



شاشة

12V



2 اختيار اختبار

شاشة

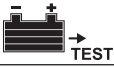

3 توصيل المشابك

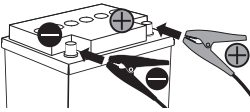

4 بدء تشغيل المركبة



5 نهاية الاختبار - مثال

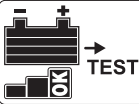

قائمة الشاشة



سالب



كافي



مشحونة

B اختبار

حالة الشحن

1 اختيار الجهد



شاشة

12V



2 اختيار اختبار

شاشة

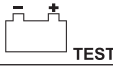

3 توصيل المشابك

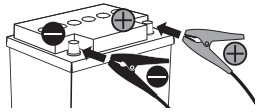

4 نهاية الاختبار - مثال



TEST

قائمة الشاشة



مشحون



فارغة من الشحن



فارغة جداً من الشحن

الصيانة C



RECOVERY

1 اختيار الجهد



شاشة

12V



2 اختيار قائمة الاختيارات المتقدمة

شاشة



3"

3 توصيل المشابك

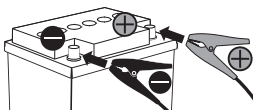

مع رموز مومضة تليها
الاشارة بأن مجريات التعافي RECOVERY
جارية.

4 نهاية المجريات - مثال

12V



OK

5 الخروج من وظيفة



3"

إختبار B



مبادل

1 اختيار الجهد



شاشة

12V



2 اختيار اختبار

شاشة



TEST



3 توصيل المشابك

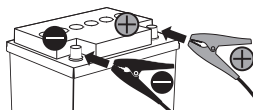

4 بدء تشغيل المركبة



5 نهاية الاختبار - مثال

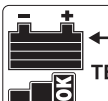

TEST



سالب

كافي

مشحونة

دائرة قصيرة

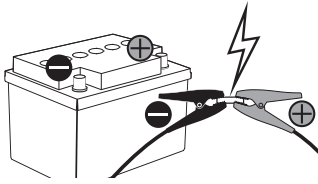

استبدال الاقطاب

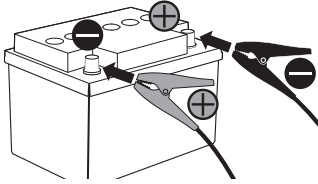

12V

12V

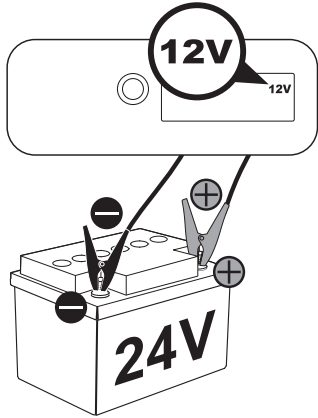

24V

التغذية بالطاقة

D

SUPPLY

إمداد

تغيير بطارية

1 اختيار الجهد



شاشة

12V



2 اختيار قائمة الاختيارات المتقدمة

شاشة

SUPPLY

3"

3 توصيل المشابك بكابلات بطارية المركبة

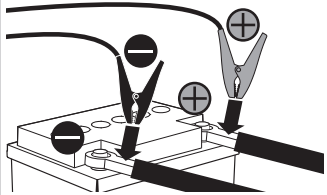

4 المركبة مغذاة بالطاقة

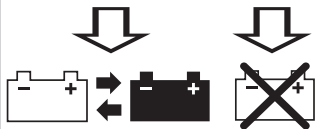

استبدال بطارية

إزالة بطارية

5 الخروج من وظيفة



3"

الصيانة C



RECOVERY

1 اختيار الجهد

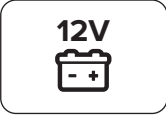

2 اختيار قائمة الاختيارات المتقدمة



3"

3 توصيل المشابك

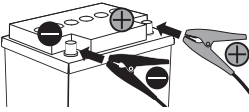

مع مؤشرات
ضوئية مومضة
تليها
الاشارة بأن
مجريات التعافي
جارية.

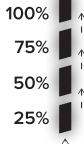

4 نهاية المجريات - مثال



5 الخروج من وظيفة



3"

الشحن / الصيانة A

الناض - تكنولوجيا الكترونية



1 اختيار الجهد

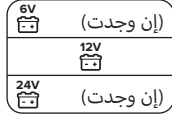

2 إختياري: اختيار قائمة الاختيارات المتقدمة



3"

3 توصيل المشابك

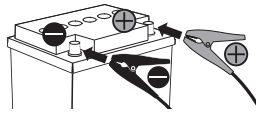

4 نهاية الشحن - مثال



نهاية الشحن PULSE - TRONIC - نتيجة إيجابية



نهاية الشحن PULSE - TRONIC - نتيجة سلبية

دائرة قصيرة

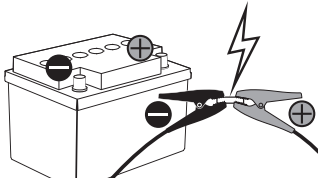

استبدال الاقطاب

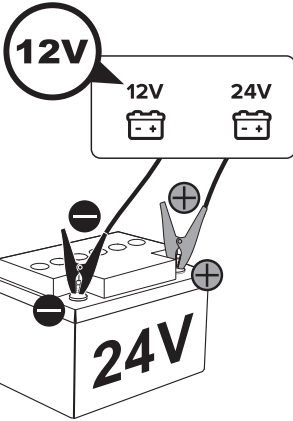
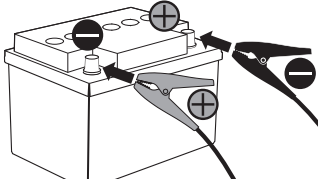

SUPPLY

إمداد

تغيير بطارية

1 اختيار الجهد



12V



2 اختيار قائمة الاختيارات المتقدمة



3"

3 توصيل المشابك بكابلات بطارية المركبة

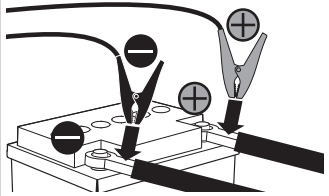

4 المركبة مغذاة بالطاقة

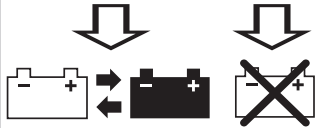

استبدال بطارية

إزالة بطارية

5 الخروج من وظيفة



3"

(EN) GUARANTEE

The manufacturer guarantees proper operation of the machines and undertakes to replace free of charge any parts should they be damaged due to poor quality of materials or manufacturing defects within 12 months of the date of commissioning of the machine, when proven by certification. Returned machines, also under guarantee, should be dispatched CARRIAGE PAID and will be returned CARRIAGE FORWARD. This with the exception of, as decreed, machines considered as consumer goods according to European directive 1999/44/EC, only when sold in member states of the EU. The guarantee certificate is only valid when accompanied by an official receipt or delivery note. Problems arising from improper use, tampering or negligence are excluded from the guarantee. Furthermore, the manufacturer declines any liability for all direct or indirect damages.

(IT) GARANZIA

La ditta costruttrice si rende garante del buon funzionamento delle macchine e si impegna ad effettuare gratuitamente la sostituzione dei pezzi che si deteriorassero per cattiva qualità di materiale e per difetti di costruzione entro 12 mesi dalla data di messa in funzione della macchina, comprovata sul certificato. Le macchine rese, anche se in garanzia, dovranno essere spedite in PORTO FRANCO e verranno restituite in PORTO ASSEGNATO. Fanno eccezione, a quanto stabilito, le macchine che rientrano come beni di consumo secondo la direttiva europea 1999/44/CE, solo se vendute negli stati membri della EU. Il certificato di garanzia ha validità solo se accompagnato da scontrino fiscale o bolla di consegna. Gli inconvenienti derivati da cattiva utilizzazione, manomissione o incuria, sono esclusi dalla garanzia. Inoltre si declina ogni responsabilità per tutti i danni diretti ed indiretti.

(FR) GARANTIE

Le fabricant garantit le fonctionnement correct des machines et s'engage à remplacer gratuitement les composants endommagés à la suite d'une mauvaise qualité de matériel ou d'un défaut de fabrication durant une période de 12 mois à compter de la mise en service de la machine attestée par le certificat. Les machines rendues, même sous garantie, doivent être expédiées en FRANCO DESTINATION et seront renvoyées en PORT DÛ. Font exception à cette règle les machines considérées comme biens de consommation selon la directive européenne 1999/44/CE et vendues aux états membres de l'EU uniquement. Le certificat de garantie n'est valable que s'il est accompagné de la preuve d'achat ou du bulletin de livraison. Tous les inconvénients dus à une utilisation incorrecte, une manipulation ou une négligence sont exclus de la garantie. La société décline en outre toute responsabilité pour tous les dommages directs ou indirects.

(ES) GARANTÍA

La empresa fabricante garantiza el buen funcionamiento de las máquinas y se compromete a efectuar gratuitamente la sustitución de las piezas que se deterioren por mala calidad del material y por defectos de fabricación en los 12 meses posteriores a la fecha de puesta en funcionamiento de la máquina, comprobada en el certificado. Las máquinas entregadas, incluso en garantía, deberán ser enviadas a PORTE PAGADO y se devolverán a PORTE DEBIDO. Son excepción, según cuanto establecido, las máquinas que se consideran bienes de consumo según la directiva europea 1999/44/CE sólo si han sido vendidas en los estados miembros de la UE. El certificado de garantía tiene validez sólo si está acompañado de resguardo fiscal o albarán de entrega. Los problemas derivados de una mala utilización, modificación o negligencia están excluidos de la garantía. Además, se declina cualquier responsabilidad por todos los daños directos e indirectos.

(DE) GEWÄHRLEISTUNG

Der Hersteller übernimmt die Gewährleistung für den einwandfreien Betrieb der Maschinen und verpflichtet sich, solche Teile kostenlos zu ersetzen, die aufgrund schlechter Materialqualität und von Herstellungsfehlern innerhalb von 12 Monaten ab der Inbetriebnahme schadhaft werden. Als Nachweis der Inbetriebnahme gilt der Garantieschein. Werden Maschinen zurückgesendet, muß dies - auch im Rahmen der Gewährleistung - FRACHTFREI geschehen. Sie werden anschließend per FRACHTNACHNACHNAME wieder zurückgesendet. Von den Regelungen ausgenommen sind Maschinen, die nach der Europäischen Richtlinie 1999/44/EG unter die Verbrauchsgüter fallen, und nur dann, wenn sie in einem Mitgliedstaat der EU verkauft worden sind. Der Garantieschein ist nur gültig, wenn ihm der Kassenbon oder der Lieferschein beiliegt. Unsere Gewährleistung bezieht sich nicht auf Schäden aufgrund fehlerhafter oder nachlässiger Behandlung oder aufgrund von Fremdeinwirkung. Außerdem wird jede Haftung für direkte und indirekte Schäden ausgeschlossen.

(RU) ГАРАНТИЯ

Компания-производитель гарантирует хорошую работу машинного оборудования и обязуется бесплатно произвести замену частей, имеющих неисправности, явившиеся следствием плохого качества материала или дефектов производства, в течении 12 месяцев с даты пуска в эксплуатацию машинного оборудования, проставленной на сертификате. Возвращенное оборудование, даже находящееся под действием гарантии, должно быть направлено на условиях ПОРТО ФРАНКО и будет возвращено в УКАЗАННОЕ МЕСТО. Из оговоренного выше исключается машинное оборудование, считающееся товарами потребления, в соответствии с европейской директивой 1999/44/ЕС, только в том случае, если они были проданы в государствах, входящих в ЕС. Гарантийный сертификат считается действительным только при условии, что к нему прилагается товарный чек или товаросопроводительная накладная. Неисправности, возникшие из-за неправильного использования, порчи или небрежного обращения, не покрываются действием гарантии. Дополнительно производитель снимает с себя любую ответственность за какой-либо прямой или непрямоy ущерб.

(PT) GARANTIA

A empresa fabricante torna-se garante do bom funcionamento das máquinas e compromete-se a efectuar gratuitamente a substituição das peças que porventura se deteriorarem devido à má qualidade de material e por defeitos de fabricação no prazo de 12 meses da data de entrada da máquina em funcionamento, comprovada no certificado. As máquinas devolvidas, mesmo se em garantia, deverão ser despachadas em PORTO FRANCO e serão devolvidas com FRETE A PAGAR. São excepção, a quanto estabelecido, as máquinas que são consideradas como bens de consumo segundo a directiva europeia 1999/44/CE, somente se vendidas nos estados-membros da EU. O certificado de garantia tem validade somente se acompanhado pela nota fiscal ou conhecimento de entrega. Os inconvenientes decorrentes de utilização imprópria, adulteração ou descuido, são excluídos da garantia. Para além disso, o fabricante exime-se de qualquer responsabilidade para todos os danos directos e indirectos.

(NL) GARANTIE

De fabrikant is garant voor de goede werking van de machines en verplicht er zich toe gratis de vervanging uit te voeren van de stukken die afslijten omwille van de slechte kwaliteit van het materiaal en omwille van fabricagefouten, binnen de 12 maanden vanaf de datum van in bedrijfstelling van de machine, bevestigd op het certificaat. De geretourneerde machines, ook al zijn ze in garantie, moeten PORTVRIJ verzonden worden en zullen op KOSTEN BESTEMMELING teruggestuurd worden. Hierop maken een uitzondering de machines die vallen onder de verbruiksartikelen overeenkomstig de Europese richtlijn, 1999/44/EG, alleen indien ze verkocht zijn in de lidstaten van de EU. Het garantiecertificaat is alleen geldig indien het vergezeld is van de fiscale reçu of van het ontvangstbewijs. De inconveniënten te wijten aan een slecht gebruik, schendingen of nalatigheid zijn uitgesloten uit de garantie. Bovendien wijst men alle verantwoordelijkheid af voor alle rechtstreekse en onrechtstreekse schade.

(EL) ΕΓΓΥΗΣΗ

Η κατασκευαστική εταιρία εγγυάται την καλή λειτουργία των μηχανών και δεσμεύεται να εκτελέσει δωρεάν την αντικατάσταση τμημάτων σε περίπτωση φθοράς τους εξαιτίας κακής ποιότητας υλικού ή ελαττωμάτων κατασκευής, εντός 12 μηνών από την ημερομηνία θέσης σε λειτουργία του μηχανήματος επιβεβαιωμένη από το πιστοποιητικό. Τα μηχανήματα που επιστρέφονται, ακόμα και αν είναι σε εγγύηση, θα στέλνονται ΧΩΡΙΣ ΕΠΙΒΑΡΥΝΣΗ και θα επιστρέφονται με έξοδα ΠΛΗΡΩΤΕΑ ΣΤΟΝ ΠΡΟΟΡΙΣΜΟ. Εξαιρούνται από τα οριζόμενα τα μηχανήματα που αποτελούν καταναλωτικά αγαθά σύμφωνα με την ευρωπαϊκή οδηγία 1999/44/EC μόνο αν πωλούνται σε κράτη μέλη της ΕΕ. Το πιστοποιητικό εγγύησης ισχύει μόνο αν συνοδεύεται από επίσημη απόδειξη πληρωμής ή απόδειξη παραλαβής. Ενδεχόμενα προβλήματα οφειλόμενα σε κακή χρήση, παραποίηση ή αμέλεια, αποκλείονται από την εγγύηση. Απορρίπτεται, επίσης, κάθε ευθύνη για οποιαδήποτε βλάβη άμεση ή έμμεση.

(RO) GARANȚIE

Fabricantul garantează buna funcționare a aparatelor produse și se angajează la înlocuirea gratuită a pieselor care s-ar putea deteriora din cauza calității scadente a materialului sau din cauza defectelor de construcție în max. 12 luni de la data punerii în funcțiune a aparatului, dovedită cu certificatul de garanție. Aparatele restituite, chiar dacă sunt în garanție, se vor expedia FĂRĂ PLATĂ și se vor restitui CU PLATA LA PRIMIRE. Fac excepție, conform normelor, aparatele care se categorisesc ca și bunuri de consum, conform directivei europene 1999/44/EC, numai dacă acestea sunt vândute în statele membre din UE. Certificatul de garanție este valabil numai dacă este însoțit de bonul fiscal sau de fișa de livrare. Nefuncționarea cauzată de o utilizare improprie, manipulare inadecvată sau neglijență este exclusă din dreptul la garanție. În plus fabricantul își declină orice responsabilitate față de toate daunele provocate direct și indirect.

(SV) GARANTI

Tillverkaren garanterar att maskinerna fungerar bra och åtar sig att kostnadsfritt byta ut delar som går sönder p.g.a. dålig materialkvalitet och defekter inom 12 månader efter idriftsättningen av maskinen, som ska styrkas av intyg. De maskiner som lämnas tillbaka, även om de täcks av garantin, måste skickas FRAKTFRITT, och kommer att skickas tillbaka PÅ MOTTAGARENS BEKOSTNAD. Ett undantag från detta utgörs av de maskiner som räknas som konsumtionsvaror enligt EU-direktiv 1999/44/EG, och då enbart om de har sålts till något av EU:s medlemsländer. Garantisdeln är bara giltig tillsammans med kvitto eller leveranssedel. Problem som beror på felaktig användning, åverkan eller vårdslöshet täcks inte av garantin. Tillverkaren fransäger sig även allt ansvar för direkt och indirekt skada.

(CS) ZÁRUKA

Výrobce ručí za správnou činnost strojů a zavazuje se provést bezplatnou výměnu dílů potřebovaných z důvodu špatné kvality materiálu a následkem konstrukčních vad do 12 měsíců od data uvedení stroje do provozu, uvedeného na záručním listě. Vracené stroje a to i v záruční době musí být odeslány se ZAPLACENÝM POŠTOVNÝM a budou vráceny na NÁKLADY PŘÍJEMCE. Na základě dohody tvoří výjimku stroje spadající do spotřebního majetku ve smyslu směrnice 1999/44/ES pouze za předpokladu, že byly prodány v členských státech EU. Záruční list má platnost pouze v případě, že je předložen spolu s účtenkou nebo dodacím listem. Poruchy vyplývající z nesprávného použití, úmyslného poškození nebo chybějící péče nespadají do záruky. Odpovědnost se dále nevztahuje na vřechny přímé a nepřímé škody.

(HR-SR) GARANCIJA

Proizvođač garantira ispravan rad strojeva i obvezuje se izvršiti besplatno zamjenu dijelova koji su oštećeni zbog loše kvalitete materijala i zbog tvorničkih grešaka, u roku od 12 mjeseci od dana pokretanja stroja, koji je potvrđen na garantnom listu. Vraćeni strojevi, i ako su pod garancijom, moraju biti poslani bez plaćanja troškova prijevoza. Iznimka su strojevi koji se vraćaju kao potrošni materijal, u skladu sa Europskom odredbom 1999/44/EC, samo ako su prodani zemljama članicama EU-a. Garantni list vrijedi samo ako je popraćen računom ili dostavnim listom. Oštećenja nastala uslijed neispravne upotrebe, izmjena izvršenih na stroju ili nemara nisu pokriveni garancijom. Proizvođač se ujedno odriče bilo kakve odgovornosti za sve izravne i neizravne štete.

(PL) GWARANCJA

Producent gwarantuje prawidłowe funkcjonowanie urządzeń i zobowiązuje się do bezpłatnej wymiany części, które zepsują się w wyniku złej jakości materiału lub wad fabrycznych w ciągu 12 miesięcy od daty uruchomienia urządzenia, poświadczonej na gwarancji. Urządzenia przesłane do Producenta, również w okresie gwarancji, należy wysłać na warunkach PORTO FRANKO, po naprawie zostaną one zwrócone na koszt odbiorcy. Zgodnie z ustaleniami wyjątkiem są te urządzenia, które są odsyłane jako dobra konsumpcyjne, zgodnie z dyrektywą europejską 1999/44/WE, wyłącznie, jeżeli zostały sprzedane w krajach członkowskich UE. Karta gwarancyjna jest ważna wyłącznie, jeżeli towarzyszy jej kwit fiskalny lub dowód dostawy. Trudności wynikające z nieprawidłowego użytkowania, naruszenia lub niedbałości o urządzenie nie są objęte gwarancją. Producent nie ponosi odpowiedzialności za wszelkie szkody pośrednie i bezpośrednie.

(FI) TAKUU

Valmistusyritys takaa koneiden hyvän toimivuuden sekä huolehtii huonolaatuisen materiaalin ja rakennusvirheiden takia huonontuneiden osien vaihdosta ilmaiseksi 12 kuukauden sisällä koneen käyttöönottopäivästä, mikä ilmenee sertifikaatista. Palautettavat koneet, myös takuussa olevat, on lähetettävä LÄHETTÄJÄN KUSTANNUKSELLA ja ne palautetaan VASTAANOTTAJAN KUSTANNUKSELLA. Poikkeuksien muodostavat koneet, jotka asetuksissa kuuluvat kulutushyödykkeisiin eurooppalaisen direktiivin 1999/44/EC mukaan vain, jos ne myydään EU:n jäsen maissa. Takuutodistus on voimassa vain, jos siihen on liitetty verotuskuitti tai todistus tavarantaimituksesta. Takuu ei kata väärinkäytöstä, vaurioittamisesta tai huolimattomuudesta johtuvia toimittoja. Lisäksi yritys kieltäytyy ottamasta vastuuta kaikista välittömistä tai välillisistä vaurioista.

(DA) GARANTI

Producenten stiller garanti for, at maskinerne fungerer ordentligt, og forpligter sig til vederlagsfrit at udskifte de dele, der måtte fremvise defekter på grund af ringe materialekvalitet eller fabrikationsfejl i løbet af de første 12 måneder efter maskinens idriftsættelsesdato, der fremgår af beviset. Selvom de returnerede maskiner er i garanti, skal de sendes FRANKO FRAGT, mens de tilbageleveres PR. EFTERKRAV. Dette gælder dog ikke for de maskiner, der i henhold til Direktivet 1999/44/EØF udgør forbrugsgoder, men kun på betingelse af at de sælges i EU-landene. Garantibeviset er kun gyldigt, hvis der vedlægges en kassebon eller fragtpapirer. Garantien dækker ikke for forstyrrelser, der skyldes forkert anvendelse, manipulering eller skødesløshed. Producenten fralægger sig desuden ethvert ansvar for alle direkte og indirekte skader.

(NO) GARANTI

Tilverkeren garanterer maskinens korrekte funksjon og forplikter seg å utføre gratis bytte av deler som blir ødelagt på grunn av en dårlig kvalitet i materialer eller konstruksjonsfeil som oppstår innen 12 måneder fra maskinens igangsetting, i overensstemmelse med sertifikatet. Maskiner som sendes tilbake, også i løpet av garantiperioden, skal skickes FRAKTFRITT och skal sendes tilbake MED BETALNING AV MOTTAKEREN, unntatt maskinene som tilhører forbrukningsvarer ifølge europadirektiv 1999/44/EC, kun hvis de selges i en av EUs medlemsstater. Garantisertifikatet er gyldig kun sammen med kvittering eller leveringsblankett. Feil som oppstår på grunn av galt bruk, manipulering eller slurv, er utelukket fra garantin. Dessuten frasier seg selskapet alt ansvar for alle direkte og indirekte skader.

(SL) GARANCIJA

Proizvajalec zagotavlja pravilno delovanje strojev in se zavezuje, da bo brezplačno zamenjal dele, ki se bodo obrabili zaradi slabe kakovosti materiala in zaradi napak pri proizvodnji v roku 12 mesecev od dneva nakupa označenega ne tem certifikatu. Izjema so le aparati, ki so del potrošnih dobrin v skladu z evropsko direktivo 1999/44/EC, le če so bili prodani v državi članici EU. Garancijsko potrdilo je veljavno le, če je priložen veljaven račun. Napake, ki izhajajo iz nepravilne uporabe, posegov ali malomarnosti, garancija ne pokriva. Poleg tega proizvajalec zavraca odgovornost za vse posredne in neposredne poškodbe. Ne delujoč aparat mora pooblaščen servis popraviti v roku 45 dni, v nasprotnem primeru se kupcu izroči nov aparat. Proizvajalec zagotavlja dobavo rezervnih delov še 5 let od nakupa izdelka. Na podlagi zakona o spremembah in dopolnitvah Zakona o varstvu potrošnikov (ZVPot-E) (Ur.l.RS št. 78/2011) podjetje Telwin s.p.a., kot organizator servisne mreže izrecno izjavlja: da velja garancija za izdelek na teritorialnem območju države v kateri je izdelek prodan končnim potrošnikom; opozarja potrošnike, da garancija in uveljavljanje zahtevkov iz naslova garancije ne izključuje pravic potrošnika, ki izhajajo iz naslova odgovornosti prodajalca za napake na blagu. ORGANIZATOR SERVISNE SLUŽBE ZA SLOVENIJO: Itehnika d.o.o., Vanganeljska cesta 26a, 6000 Koper, tel: 05/625-02-08.

(SK) ZÁRUKA

Výrobca ručí za správnú činnosť strojov a zaväzuje sa vykonať bezplatnú výmenu dielov opotrebovaných z dôvodu zlej kvality materiálu a následkom konštrukčných väd do 12 mesiacov od dátumu uvedenia stroja do prevádzky, uvedeného na záručnom liste. Vrátené stroje a to i v podmienkach záručnej doby musia byť odoslané so ZAPLATENÝM POŠTOVNÝM a budú vrátené na NÁKLADY PRÍJEMCU. Na základe dohody výnimku tvoria stroje spadajúce do spotrebného majetku, v zmysle smernice 1999/44/ES, len za predpokladu, že boli predané v členských štátoch EÚ. Záručný list je platný len v prípade, keď je predložený spolu s účtenkou alebo dodacím listom. Poruchy vyplývajúce z nesprávneho použitia, neoprávneného zásahu alebo nedostatočnej starostlivosti nespádajú do záruky. Zodpovednosť sa ďalej nevzťahuje na všetky priame i nepriame škody.

(HU) JÓTÁLLÁS

A gyártó cég jótállást vállal a gépek rendeltetésszerű üzemeléséért illetve vállalja az alkatrészek ingyenes kicserélését ha azok az alapanyag rossz minőségéből valamint gyártási hibából erednek a gép üzembe helyezésének a bizonylat szerint igazolható napjától számítve 12 hónapon belül. A cserélendő alkatrészeket még a jótállás keretében is BÉRMENTESEN kell visszaküldeni, amelyek UTÓVÉTEL lesznek a vevőhöz kiszállítva. Kivételt képeznek e szabály alól azon gépek, melyek az Európai Unió 199/44/EC irányelve szerint meghatározott fogyasztási cikknek minősülnek, s az EU tagországaiiban kerültek értékesítésre. A jótállás csak a blokkli igazolás illetve szállítólévél mellékeléttel érvényes. A nem rendeltetésszerű használatból, megrongálásból illetve nem megfelelő gondossággal való kezelésből eredő rendelleneségek a jótállást kizárják. Kizárt továbbá bármintemű felelősségvállalás minden közvetlen és közvetett kárért.

(LT) GARANTIJA

Gamintojas garantuoja nepriekaištingą įrenginio veikimą ir įsipareigoja nemokamai pakeisti gaminio dalis, susidėvėjusias ar susigadinusias dėl prastos medžiagos kokybės ar dėl konstrukcijos defektų 12 mėnesių laikotarpyje nuo įrenginio paleidimo datos, kuri turi būti paliudyta pažymėjimu. Gražinami įrenginiai, net ir galiojant garantijai, turi būti siunčiami ir bus sugrąžinti atgal PIRKĖJO lėšomis. Išimti aukščiau aprašytai sąlygai sudaro prietaisai, kurie pagal 1999/44/EC Europos direktyvą gali būti laikomi plataus vartojimo prekėmis bei yra parduodami tik ES šalyse. Garantinis pažymėjimas galioja tik tuo atveju, jei yra lydimas fiskalinio čekio arba pristatymo dokumento. Į garantiją nėra įtraukti nesklandumai, susiję su netinkamu prietaiso naudojimu, aplaidumu ar prasta jo priežiūra. Gamintojas taip pat atsiriboja nuo atsakomybės už bet kokius tiesioginius ar netiesioginius nuostolius.

(ET) GARANTI

Tootjafirma vastutab masinate hea funktsioneerimise eest ja kohustub asendama tasuta osad, mis riknevad halva kvaliteediga materjali ja konstruktsioonidefektide tõttu, 12 kuu jooksul alates masina käikupanemise sertifikaadil tõestatud kuupäevast. Tagasi saadetavad masinad, ka kehtiva garantiiga, tuleb saata TASUTUD POSTIMAKSUGA ja nende tagastamise SAATEKULUD ON KAUBASAAJA TASUDA. Nagu kehtestatud, teevad erandi masinad, mis kuuluvad euroopa normatiivi 1999/44/EC kohaselt tarbekauba kategooriasse ja ainult siis, kui müüud ÜE liikmesriikides. Garantisertifikaat kehtib ainult koos ostu- või kätetoimetamiskviitungiga. Garantii ei hõlma riknemisi, mis on põhjustatud seadme väärest käsitemisest, modifitseerimisest või hoolimatust kasutamisest. Peale selle ei vastuta firma kõigi otseste või kaudsete kahjude eest.

(LV) GARANTIJA

Ražotājs garantē mašīnu labu darbību un apņemas bez maksas nomainīt detaļas, kuras nodilst materiāla sliktas kvalitātes dēļ vai ražošanas defektu dēļ 12 mēnešu laikā kopš sertifikātā norādītā mašīnas ekspluatācijas sākuma datuma. Atpakal nosūtāmas mašīnas, pat to garantijas laikā, ir jānosūta saskaņā ar FRANKO-OSTA noteikumiem un ražotājs tās atgriež uz NORĀDĪTO OSTU. Minētie nosacījumi neattiecas uz mašīnām, kuras saskaņā ar Eiropas direktīvu 1999/44/EC tiek uzskatītas par patēriņa precī, bet tikai gadījumā, ja tās tiek pārdotas ES dalībvalstīs. Garantijas sertifikāts ir spēkā tikai kopā ar kases čeku vai pavadzīmi. Garantija neattiecas uz gadījumiem, kad bojājumi ir radušies nepareizās izmantošanas, noteikumu neievērošanas vai nolaidības dēļ. Turklāt, šajā gadījumā ražotājs neņem vērību par tiešajiem un netiešajiem zaudējumiem.

(BG) ГАРАНЦИЯ

Фирмата производител гарантира за доброто функциониране на машините и се задължава да извърши безплатно подмяната на части, които са се повредили, заради некачествен материал или производствени дефекти, до 12 месеца от датата на пускане в действие на машината, доказана с гаранционна карта. Върнатите машини, дори и в гаранция, трябва да бъдат изпратени със ЗАПЛАТЕН ПРЕВОЗ и ще бъдат върнати с НАЛОЖЕН ПЛАТЕЖ. С изключение на машините, които се считат за движимо имущество за постоянно ползване, както е установено от европейската директива 1999/44/EC, само ако машините са продавани в страни членки на Европейския съюз. Гаранционната карта е валидна, само ако е придружена от фискален бонус или разписка за доставка. Нередностите, произтичащи от лоша употреба или небрежност, са изключени от гаранцията. Освен това се отклонява всякаква отговорност за директни или индиректни щети.

(TR) GARANTİ

Üretici, makinelerin düzgün şekilde çalışmasını garanti eder ve malzeme kalitesi veya üretim hatası nedeniyle hasar görmesi durumunda belgelendirme ile kanıtlandığında, makinenin devreye alınma tarihinden itibaren 12 ay içinde, parçaları ücretsiz olarak değiştirmeyi taahhüt eder. İade edilen makineler de garanti kapsamında olup, NAVLUN SATICIYA AİT gönderilir ve NAVLUN ALICIYA AİT iade edilir. Kararlaştırıldığı gibi, 1999/44 / EC sayılı Avrupa direktifine göre tüketici malları olarak kabul edilen makinelerin, yalnızca AB üye devletlerinde satılması bu durumun istisnasıdır. Garanti belgesi, yalnızca resmi bir makbuz veya teslimat notu eşliğinde geçerlidir. Yanlış kullanım, kurcalama veya ihmalden kaynaklanan sorunlar garanti kapsamı dışındadır. Ayrıca, üretici doğrudan veya dolaylı tüm zararlardan dolayı sorumluluk kabul etmemektedir.

(AR) الضمان

تضمن الشركة المُصنعة جودة الماكينات، كما أنها تتعهد باستبدال قطع مجاناً في حالة تلفها بسبب سوء جودة المادة وعيوب التصنيع وذلك في خلال 12 شهر من تاريخ تشغيل الماكينة المثبت في الشهادة. سُرسل الماكينات المسترجعة - حتى وإن كانت في الضمان- على حساب المُرسَل ويتم استرجاعهم على حساب المستلم. وذلك باستثناء -كما هو مقرر- الماكينات التي تُعتبر سلع استهلاكية وفقاً للتوجيه الأوروبي رقم 44 لعام 1999 - الاتحاد الأوروبي "CE/44/1999"، والتي يتم بيعها فقط في الدول الأعضاء في الاتحاد الأوروبي. تسري شهادة الضمان فقط إذا كان معها إيصال أو مذكرة تسليم. لا يشمل الضمان المشاكل التي تنتج عن سوء الاستخدام أو العبث أو الإهمال. كما أنها لا تتحمل أي مسؤولية عن جميع الأضرار المباشرة وغير المباشرة.

(EN) CERTIFICATE OF GUARANTEE
(IT) CERTIFICATO DI GARANZIA
(FR) CERTIFICAT DE GARANTIE
(ES) CERTIFICADO DE GARANTIA
(DE) GARANTIEKARTE
(RU) ГАРАНТИЙНЫЙ СЕРТИФИКАТ
(PT) CERTIFICADO DE GARANTIA
(NL) GARANTIEBUIJS
(EL) ΠΙΣΤΟΠΟΙΗΤΙΚΟ ΕΓΓΥΗΣΗΣ

(RO) CERTIFICAT DE GARANȚIE
(SV) GARANTISEDEL
(CS) ZÁRUČNÍ LIST
(HR-SR) GARANTNI LIST
(PL) CERTYFIKAT GWARANCJI
(FI) TAKUUTODISTUS
(DA) GARANTIBEVIS
(NO) GARANTIBEVIS
(SL) CERTIFICAT GARANCIJE

(SK) ZÁRUČNÝ LIST
(HU) GARANCIÁLEVÉL
(LT) GARANTINIS PAŽYMĖJIMAS
(ET) GARANTIISERTIFIKAAT
(LV) GARANTIJAS SERTIFIKĀTS
(BG) ГАРАНЦИОННА КАРТА
(TR) GARANTİ SERTİFİKASI
(AR) شهادة الضمان

MOD. / MONT / MQD / ÜRLAP / MUDEL / МОДЕЛ / St. / Br.

(EN) Date of buying - (IT) Data di acquisto - (FR) Date d'achat - (ES) Fecha de compra - (DE) Kaufdatum - (RU) Дата продажи - (PT) Data de compra - (NL) Datum van aankoop - (EL) Ημερομηνία αγοράς - (RO) Data achiziției - (SV) Inköpsdatum - (CS) Datum zakoupení - (HR-SR) Datum kupnje - (PL) Data zakupu - (FI) Ostopäivämäärä - (DA) Købsdato - (NO) Innkjøpsdato - (SL) Datum nakupa - (SK) Dátum zakúpenia - (HU) Vásárlás kelte - (LT) Pirkimo data - (ET) Ostu kuupäev - (LV) Pirkšanas datums - (BG) ДАТА НА ПОКУПКАТА - (TR) Satın Alma Tarihi - (AR) تاريخ الشراء

NR / ARIQM / É / Ć / HOMEP:

(EN) Sales company (Name and Signature)
(IT) Ditta rivenditrice (Timbro e Firma)
(FR) Revendeur (Chachet et Signature)
(ES) Vendedor (Nombre y sello)
(DE) Händler (Stempel und Unterschrift)
(RU) ШТАМП И ПОДПИСЬ (ТОРГОВОГО ПРЕДПРИЯТИЯ)
(PT) Revendedor (Carimbo e Assinatura)
(NL) Verkooper (Stempel en naam)
(EL) Κατάστημα πώλησης (Σφραγίδα και υπογραφή)
(RO) Reprezentant comercial (Stampila și semnătură)
(SV) Återförsäljare (Stämpel och Underskrift)
(CS) Prodejce (Razítko a podpis)
(HR-SR) Tvrtka prodavatelj (Pečat i potpis)

(PL) Firma odsprzedająca (Pieczęć i Podpis)
(FI) Jälleenympiä (Leima ja Allekirjoitus)
(DA) Forhandler (stempel og underskrift)
(NO) Forhandler (Stempel og underskrift)
(SL) Prodajno podjetje (Zig in podpis)
(SK) Predajca (Pečiatka a podpis)
(HU) Eladás helye (Pecset és Aláírás)
(LT) Pardavėjas (Antspaudas ir Parašas)
(ET) Edasimüügi firma (Templ ja allkiri)
(LV) Izplatītājs (Zīmogs un paraksts)
(BG) ПРОДАВАЧ (Печат и Печат)
(TR) Satıcı Firma (Ad imza)
(AR) شركة المبيعات (ختم وتوقيع)



(EN) The product is in compliance with:
(FR) Il produit est conforme à:
(ES) Het produkt overeenkomstig de:
(DE) Die maschine entspricht:
(RU) Заявляется, что изделие соответствует:
(PT) El producto es conforme as:
(NL) O product is conforme as:
(EL) Το προϊόν είναι κατασκευασμένο σύμφωνα με τη:

(RO) Produsul este conform cu:
(SV) Att produkten är i överensstämmelse med:
(CS) Výrobek je v súlade so:
(HR-SR) Proizvod je u skladu sa:
(PL) Produkt spełnia wymagania następujących Dyrektyw:
(FI) Että laite mallia on yhdenmukainen direktiivissä:
(DA) At produktet er i overensstemmelse med:
(NO) At produktet er i overensstemmelse med:
(SL) Proizvod je v skladu z:

(SK) Výrobek je v súlade s:
(HU) A termék megfelel a következőknek:
(LT) Produktas atitinka:
(ET) Toode on kooskõlas:
(LV) Izstrādājums atbilst:
(BG) Продуктът отговаря на:
(TR) Uyumluluk:
(AR) المنتج متوافق مع:

(EN) DIRECTIVES - (IT) DIRETTIVE - (FR) DIRECTIVES - (ES) DIRECTIVAS - (DE) RICHTLINIEN - (RU) ДИРЕКТИВЫ - (PT) DIRECTIVAS - (NL) RICHTLIJNEN - (EL) ΠΡΟΔΙΑΓΡΑΦΕΣ - (RO) DIRECTIVE - (SV) DIREKTIV - (CS) SMĚRNICE - (HR-SR) DIREKTIVE - (PL) DYREKTYWY - (FI) DIREKTIIVIT - (DA) DIREKTIVER - (NO) DIREKTIVER - (SL) DIREKTIVE - (SK) SMERNICE - (HU) IRÁNYELVEK - (LT) DIREKTYVOS - (ET) DIREKTIIVID - (LV) DIREKTĪVAS - (BG) ДИРЕКТИВИ - (TR) YÖNERGELER - (AR) توجيه

LVD 2014/35/EU

EMC 2014/30/EU

RoHS 2011/65/EU + 2015/863/EU